

The Outdoor Collection

2019

sofas, modular sofas, chaise longue,
armchairs, ottomans, tables,
chairs, complements, small tables

divani, divani componibili,
chaise longue, poltrone, pouf, tavoli,
sedie, complementi, tavolini

B&B
ITALIA **OUTDOOR**

Designer index Indice Designer

Antonio Citterio	Edward Barber and Jay Osgerby	176 Husk Outdoor
4 Ribes	114 Tobi-Ishi Outdoor	184 Ravel
26 Mirto Outdoor	Nipa Doshi and Jonathan Levien	188 Fat-Fat Outdoor
46 Erica '19	118 Bay	Naoto Fukasawa
58 Erica	126 Tabour Outdoor	192 Fiore
66 Ray Outdoor Natural	Patricia Urquiola	196 Papilio Shell Outdoor
72 Ray Outdoor Fabric	130 Butterfly	198 Titikaka
80 Gio	136 Fat-Sofa Outdoor	202 Awa Outdoor
92 Charles Outdoor	142 Canasta	Jean-Marie Massaud
102 Ginestra	150 Canasta '13	212 Springtime
110 Gelso	158 Canasta Tables	220 Overscale Flames Outdoor
112 Frank Outdoor	166 Crinoline	

Marcel Wanders

224
White Collection

Jakob Wagner

204
Link Outdoor

Jeffrey Bennett

208
Cosmos Outdoor

B&B Italia CR&S

228
Kaleidos - Kyra - Twist

234
Karam

Product index Indice prodotti

202 Awa Outdoor	46 Erica '19	204 Link Outdoor	198 Titikaka
118 Bay	188 Fat-Fat Outdoor	26 Mirto Outdoor	114 Tobi-Ishi Outdoor
130 Butterfly	136 Fat-Sofa Outdoor	220 Overscale Flames Outdoor	228 Twist - Kaleidos - Kyra
142 Canasta	112 Frank Outdoor	196 Papilio Shell Outdoor	224 White Collection
150 Canasta '13	192 Fiore	72 Ray Outdoor Fabric	
158 Canasta Tables	110 Gelso	66 Ray Outdoor Natural	334 Contacts, Contatti
92 Charles Outdoor	102 Ginestra	184 Ravel	236 Credits, Crediti
208 Cosmos Outdoor	80 Gio	4 Ribes	239 Overview
166 Crinoline	176 Husk Outdoor	212 Springtime	253 Technical data, Schede tecniche
58 Erica	234 Karam	126 Tabour Outdoor	328 Fabrics, Tessuti

ENG

Ribes is the new modular seating system designed by Antonio Citterio with a focus on versatility, customisation, colour and research on materials. Sofas, central and end elements, chaises longues and ottomans all come in a huge variety of shapes and sizes that lend themselves to being arranged in an outdoor space according to personal taste thanks to the exceptional versatility of the modular components and the availability of a vast range of covers and finishes. The starting point is a futon base with flexible glass-fibre slats resting on an aluminium frame to which two types of arm or back rest can be attached as desired: one with a polypropylene fibre interlacing, the other with a roller cushion.

ITA

Ribes è il nuovo sistema di sedute componibili disegnato da Antonio Citterio, che mette al centro del progetto i temi della flessibilità, della personalizzazione, del colore e della ricerca sui materiali. Divani, elementi centrali e terminali, chaise longue e pouf, proposti in numerose tipologie e dimensioni, consentono di interpretare lo spazio outdoor in maniera molto personale grazie all'estrema flessibilità compositiva e alla possibilità di scegliere tra numerosissimi rivestimenti e finiture. Il punto di partenza è una base "futon" con doghe flessibili in fibra di vetro, appoggiate su una struttura in alluminio, sulla quale fissare liberamente braccioli e schienali previsti in due tipologie: a telaio con intreccio in fibra di polipropilene oppure a rullo.

Ribes,

the starting point is a futon base with flexible glass-fibre slats resting on an aluminium frame.

il punto di partenza è una base "futon" con doghe flessibili in fibra di vetro, appoggiate su una struttura in alluminio.

Opposite, nella pagina accanto:
Ribes, modular sofa, divano componibile
RBR141LB_2 - RBR190PA

Erica '19, small armchairs, poltroncine - NE80P
Frank Outdoor, ottomans, pouf - OF58P
Canasta, small tables, tavolini - TCN3

Canasta, small tables, tavolini - TCN15
Kyra, carpets, tappeti - TY200
Karam, floor baskets, ceste da terra - KA02





These pages, in queste pagine:
Ribes, modular sofa, divano componibile
 RBR141LB_2 - RBR190PA

Erica '19, small armchairs, poltroncine - NE80P
Frank Outdoor, ottomans, pouf - OF58P
Canasta, small tables, tavolini - TCN3

Canasta, small tables, tavolini - TCN15
Kyra, carpets, tappeti - TY200
Karam, floor baskets, ceste da terra - KA02



These pages, in queste pagine:
Ribes, modular sofa, divano componibile
 RBR141LB_2 - RBR190PA

Erica '19, small armchair, poltroncina - NE80P
Canasta, small tables, tavolini - TCN3
Canasta, small tables, tavolini - TCN15

Karam, floor baskets, ceste da terra - KA02
Kyra, carpets, tappeti - TY200



ENG

The textile choice is also extensive and colourful with designs that have been inspired by traditional fabrics collected during numerous trips to South America, reinterpreted and redesigned using very clear colour schemes that still leave a wide choice of different combinations allowing maximum customisation. The seat, back and arm cushions can be covered as desired in wide or narrow-striped, dotted or single-colour material, all in various shades that coordinate with each other. There is also a choice of trim colours in natural, blue and red tones.

ITA

Anche la proposta tessile è ricca e colorata, con fantasie che si ispirano a tessuti tradizionali raccolti nel corso di numerosi viaggi in Sudamerica, reinterpretati e ridisegnati secondo schemi cromatici ben precisi, che lasciano tuttavia grande libertà di scelta negli abbinamenti così da offrire innumerevoli possibilità di personalizzazione. I cuscini sedile, schienale e bracciolo possono infatti essere vestiti a piacere con tessuti a righe larghe, righe strette, puntinati e uniti, tutti in varie tonalità tra loro coordinabili. A scelta anche il colore dei profili, previsti nei toni naturale, blu e rosso.

ENG

The seating system is enriched with seat cushions intended as comfortable mattresses to stretch out on and several shapes of back- and armrest cushion, all containing a new filling giving Ribes a particularly lived-in and soft look. Colour comes into play in the painted frames in shades of anthracite, sage and clay. These same tones are then picked up in the back and arm supports combining the colours sage and clay with a natural-coloured interlacing and anthracite to one in a matching shade, and the same for the brackets of the roller sections.

Opposite, nella pagina accanto:
Ribes, modular sofa,
divano componibile - RBR145LB_1

Mirto Outdoor, folding small armchair,
poltroncina pieghevole - MI59N
Fat-Fat Outdoor, tray, vassoio - OF42V

ITA

Il sistema di sedute si arricchisce di cuscini sedile pensati come comodi materassi dove rilassarsi e varie tipologie di cuscini schienale e bracciolo, tutti realizzati con una nuova imbottitura che dona a Ribes un aspetto vissuto particolarmente morbido. Il tema del colore viene introdotto dalle strutture verniciate nelle tonalità antracite, salvia e argilla. Nuance riprese dagli schienali e braccioli a telaio, che abbinano il salvia e l'argilla ad un intreccio naturale e l'antracite ad un intreccio tono su tono, e dai supporti delle versioni a rullo.

Fat-Fat Outdoor, tray, vassoio - OF62V
Kyra, carpets, tappeti - TY200
Karam, floor baskets, ceste da terra - KA02



Mirto Outdoor, table, tavolo - TMO162Q
Erica '19, stackable chairs, sedie impilabili - NE61S_1
Frank Outdoor, ottoman, pouf - OF58P



These pages, in queste pagine:
Ribes, modular sofa, divano componibile
 RBR145LB_1

Mirto Outdoor, folding small armchair,
 poltroncina pieghevole - MI59N
Fat-Fat Outdoor, tray, vassoio - OF42V

Fat-Fat Outdoor, tray, vassoio - OF62V
Erica '19, stackable chairs, sedie impilabili - NE61S_1
Kyra, carpets, tappeti - TY200

Karam, floor baskets, ceste da terra - KA02
Mirto Outdoor, table, tavolo - TMO162Q
Frank Outdoor, ottoman, pouf - OF58P









These pages, in queste pagine:
Ribes, modular sofa, divano componibile
 RBR141LB_3 - RB201T_3

Mirto Outdoor, folding small armchair,
 poltroncina pieghevole - MI59N
Frank Outdoor, ottoman, pouf - OF58P

Fat-Fat Outdoor, small table,
 tavolino - OTF62A
Fat-Fat Outdoor, tray, vassoio - OF42V

Kyra, carpets, tappeti - TY200
Karam, floor baskets,
 ceste da terra - KA02





ENG

Because it is so versatile, Ribes can also be reconfigured over time by adding new elements as well as altering the functional use of existing ones.

By substituting, adding or varying the position of the back and armrests, a sommier can turn into a vis-à-vis sofa, a sofa become an island and a corner seating plan transform into a comfortable bed. Ribes means transformation and is especially suited to those areas that are neither in-nor outside: verandas, shady patios, under a loggia or on a covered terrace allowing a fluid approach to the open spaces in the home.

ITA

Grazie alla flessibilità del sistema, Ribes può essere modificato nel tempo aggiungendo nuovi elementi, ma anche cambiando la funzione d'uso di quello esistenti. Sostituendo, aggiungendo o modificando la posizione di schienali e braccioli, un sommier può diventare un vis-à-vis, un divano può diventare un'isola, un angolare può diventare un comodo letto. Una natura trasformabile quella di Ribes, che si trova particolarmente a suo agio negli spazi di passaggio tra interno ed esterno, nelle verande o all'ombra di un patio, sotto un loggiato o un terrazzo coperto, per vivere con fluidità la casa e gli spazi aperti.

ENG

A classic is born. It expresses Antonio Citterio's stable elegance. Different types of seat: chairs, armchairs and a sunbeds are included in the collection. The folding armchair revisits the classic shape of the director's chair, with exclusive details. All sizes of tables, small tables and consoles have the same frame and top in painted aluminium, in brushed natural Iroko slats, in Calacatta white porcelain stoneware or in enamelled lava stone with anthracite, clay, sage decoration. Resistant and long-lasting, formally and physically. The quality and attention to detail make Mirto a collection that is made to last.

ITA

Nasce un classico che esprime l'eleganza stabile e riconoscibile del suo autore. Fanno parte della collezione diverse tipologie di seduta: sedie, poltrone, lettini con schienale reclinabile ed una poltroncina pieghevole che rielabora il lessico della classica tipologia da regista, con dettagli accurati. Tavoli, tavolini e console hanno la stessa struttura e top in lamiera verniciata, con doghe di Iroko naturale spazzolato, in gres porcellanato bianco Calacatta o in pietra lavica smaltata con decoro antracite, argilla, o salvia. L'aspetto qualitativo e la cura dei dettagli fanno di Mirto una collezione fatta per durare nel tempo.

Mirto Outdoor,

the quality and attention to detail make Mirto a collection that is made to last.

l'aspetto qualitativo e la cura dei dettagli fanno di Mirto una collezione fatta per durare nel tempo.

Opposite, nella pagina accanto:
Mirto Outdoor,
chaise longue - M1200CL







This page, in questa pagina:
Mirto Outdoor,
 chaise longue - MI74CL_P



This page, in questa pagina:
Mirto Outdoor, chaise longue with small
 mattress, headrest cushion,

chaise longue con materassino
 e cuscino poggiatesta
 MI74CL - MI74CL_SEW - MI40PW

Mirto Outdoor, chaise longue
 with small mattress,
 headrest cushion and terry cloths,

chaise longue con materassino,
 cuscino poggiatesta e federe
 MI74CL - MI74CL_SEW - MI40PW - MI_CLF - MI40PF

ENG

Details like the light aluminium structure, the mesh in Batyline® Canatex, in which hemp fibre confers a more rustic natural look compared to plastics that are usually used in this sector. The edges are cut, sewn and glued masterfully around the profiles to create minimal décor.

ITA

Dettagli come la struttura leggera in alluminio, la rete in Batyline® Canatex, la cui fibra di canapa conferisce una mano più rustica e naturale rispetto alle plastiche in uso nel settore. I bordi tagliati, cuciti e incollati con sapienza seguono i profili e dettano il decoro minimal.



Mirto Outdoor, small armchair,
poltroncina
MI65P



Opposite, nella pagina accanto
Mirto Outdoor, small armchair,
poltroncina - MI65P

This page, in questa pagina:
Mirto Outdoor, chair, sedia
MI58S



Mirto Outdoor, table,
tavolo - MI250TG
Twist, carpet, tappeto - TW300



These pages, in queste pagine:
Mirto Outdoor,
table, tavolo - MI250TG

Mirto Outdoor, chairs, sedie - MI58S
Mirto Outdoor, small armchairs,
poltroncine - MI65P

Mirto Outdoor, console
MI250_6G
Twist, carpet, tappeto - TW300

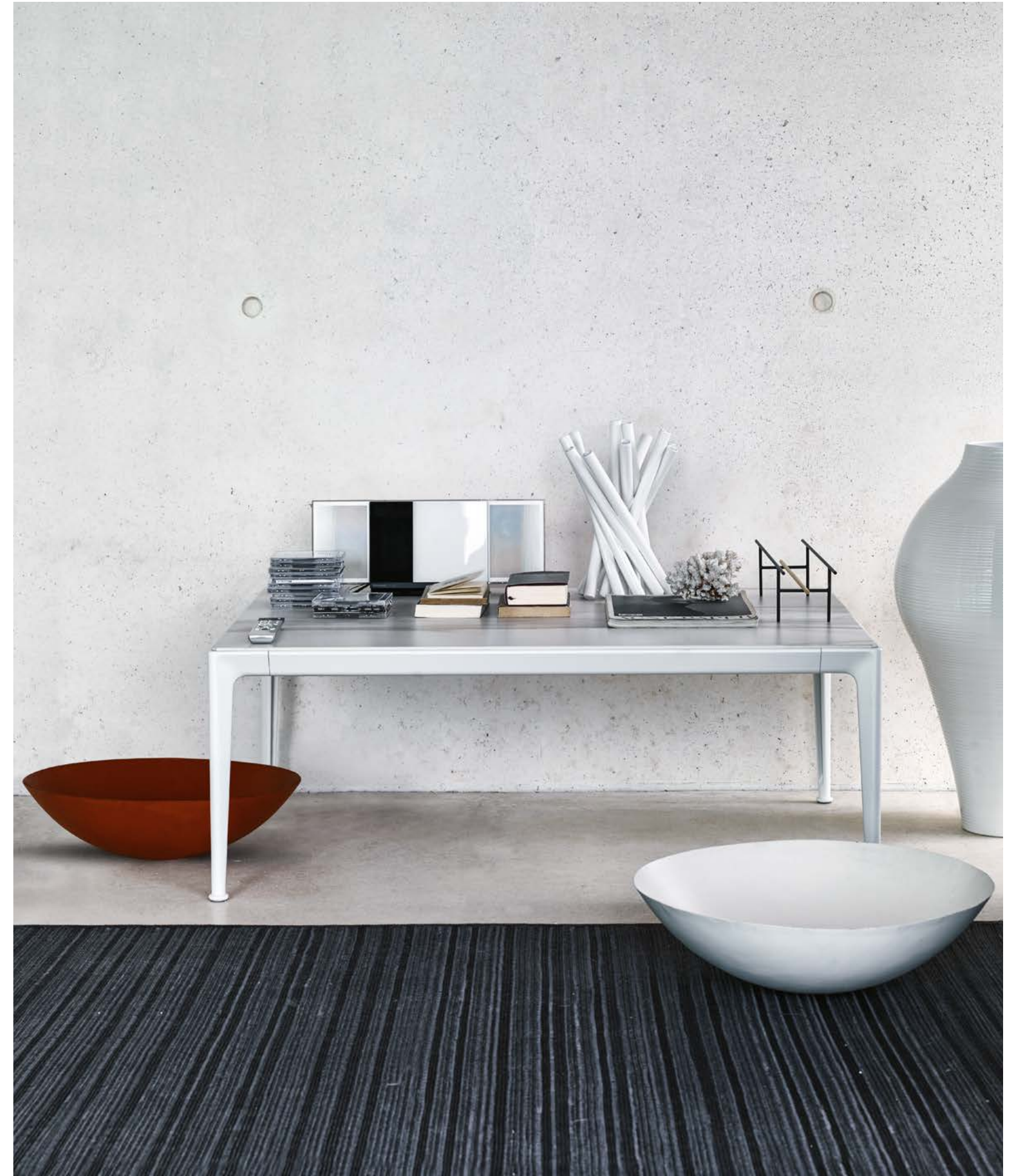

Opposite, nella pagina accanto:
Mirto Outdoor,
small table, tavolino - MI120_4G

Twist, carpet, tappeto - TW300
White Collection vase, vaso
AB20046B

Bunch, vase, vaso - AB20031B
see catalogue "The Collection"
vedi catalogo "The Collection"



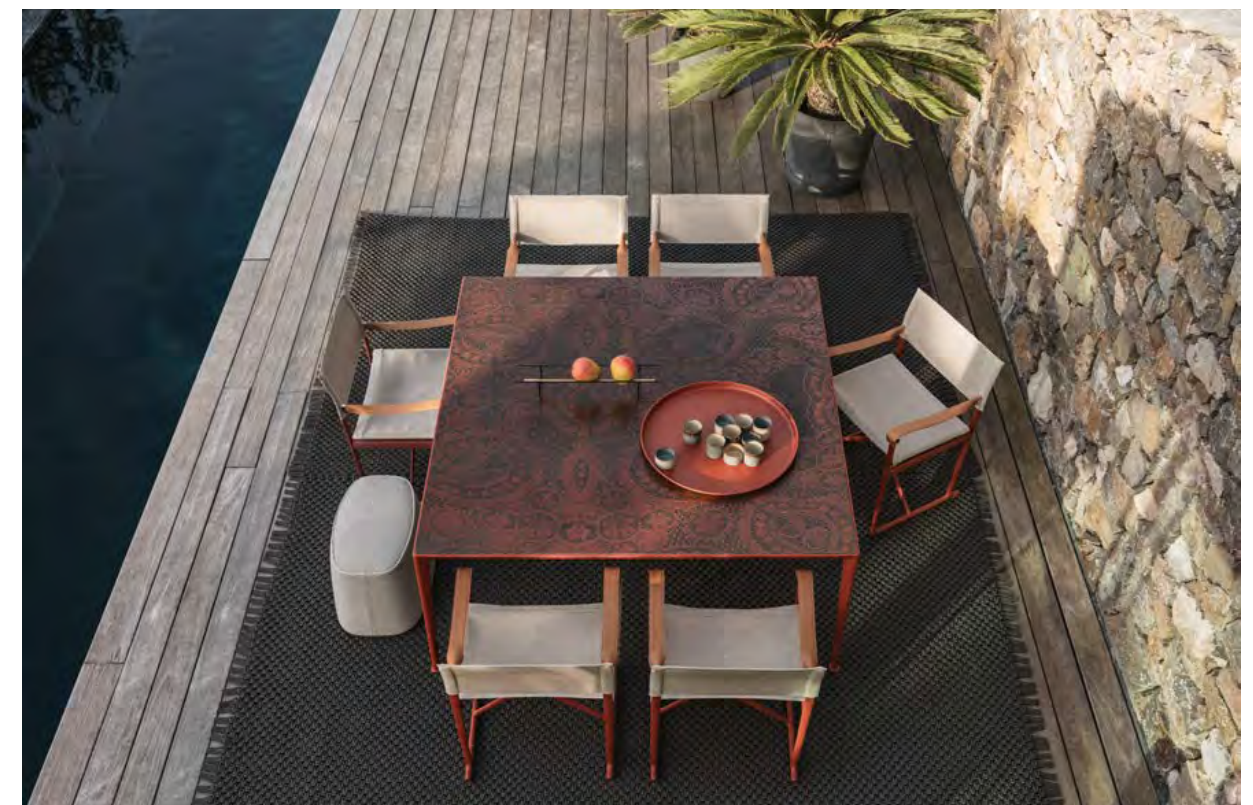

These pages, in queste pagine:
Mirto Outdoor, table, tavolo - TMO162Q

Mirto Outdoor, folding small armchairs,
 poltroncine pieghevoli - MI59N

Frank Outdoor, ottoman, pouf - OF58P
Fat-Fat Outdoor, tray, vassoio - OF42V

Kyra, carpets, tappeti - TY200



These pages, in queste pagine:
Mirto Outdoor, table top,
piano tavolo - TMO222

Opposite, nella pagina accanto:
Mirto Outdoor, enamelled lava stone with
sage, anthracite and clay decoration

pietra lavica smaltata
con decoro salvia
antracite e argilla



ENG

In 2019 the Mirto collection is also being expanded to include new designs and finishes starting with the folding director's chair now in ecru canvas with natural thick leather armrests and a die-cast aluminium frame in the new colours, clay and sage.

There is also a series of very innovative dining, small and console tables in several sizes that reproduce the collection's minimalist design elements with a fresh take on colours and decorations.

The die-cast aluminium frame comes in three new varnishes - clay, sage and anthracite - and the table tops are made of black lava stone laid out in designs based on traditional Sicilian lace in the three different frame shades. A really innovative technique has been used to manufacture the decorative tiles using a special material obtained by crushing recycled electronic equipment screens which is then applied to the surface of the tiles using an exclusive production process.

ITA

La collezione Mirto si amplia nel 2019 con nuove proposte e finiture, a partire dalla sedia regista pieghevole ora presentata con un rivestimento in tela ecru con braccioli in cuoio naturale e struttura in pressofusione d'alluminio nei nuovi colori argilla e salvia. La grande novità è rappresentata dalla serie di tavoli da pranzo, tavolini e console in varie dimensioni che riprendono il disegno essenziale di quelli già parte della collezione, ma introducono i temi del colore e del decoro. Le strutture in pressofusione d'alluminio si presentano verniciate nei tre nuovi colori argilla, salvia e antracite, mentre i piani sono realizzati con piastrelle di pietra lavica smaltata con decori che riproducono il disegno di un pizzo siciliano tradizionale da abbinare alle tre tonalità delle strutture. La tecnica di stampa delle piastrelle è altamente innovativa e utilizza per il decoro uno speciale materiale ottenuto dalla frantumazione del vetro di monitor e strumenti elettronici dismessi, poi applicato alla superficie delle piastrelle tramite un esclusivo processo di lavorazione.

Opposite, nella pagina accanto:
Mirto Outdoor, small table, tavolino - TMO162_4
Mirto Outdoor, small table, tavolino - MI54T

Frank Outdoor, ottoman, pouf - OF58P
Kyra, carpet, tappeto - TY200
Karam, floor baskets, ceste da terra - KA02

ENG

The Erica collection of sofas, armchairs and small chairs that was so successfully launched in 2017 has been enhanced by new sofas, still based on the same characteristic curved backrest and interlacing as before but offering a deeper seat and lived-in appearance. The sofas come in three extra-comfortable sizes - the 170 and 216 cm styles with a 96 cm deep seat and the 153 cm version with a 140 cm seat - and the cushions have a different type of filling giving an even softer and more natural look and making them even more inviting.

ITA

Erica, la collezione di divani, poltrone e poltroncine presentata con successo nel 2017, si arricchisce di nuovi divani che riprendono lo schienale curvo e l'intreccio caratteristici della serie, ma si distinguono per la seduta più profonda e l'aspetto vissuto. I divani sono proposti in tre misure particolarmente accoglienti 170 e 216 cm con seduta profonda 96 cm e 153 cm con seduta profonda 140 cm e prevedono, per i cuscini, una nuova tipologia di imbottitura che conferisce al prodotto un aspetto più morbido e naturale, un vero e proprio invito al relax.

Erica '19,

the collection has been enhanced by new versions for sofa, chair and armchair, offering a deeper seat and lived-in appearance.

la collezione si arricchisce di nuove versioni, divano, sedia e poltroncina che si distinguono per la seduta più profonda e l'aspetto vissuto.

Opposite, nella pagina accanto
Erica '19, sofa, divano - NE153
Erica '19, small armchairs, poltroncine - NE80P

Fat-Fat Outdoor, small table, tavolino - OFT62
Fat-Fat Outdoor, small table, tavolino - OFT42





These pages, in queste pagine:
Erica '19, sofa, divano - NE153

Erica '19, small armchairs,
poltroncine - NE80P

Fat-Fat Outdoor, small table, tavolino - OFT62
Fat-Fat Outdoor, small table, tavolino - OFT42



This page, in questa pagina:
Erica '19, small armchairs
poltroncine - NE80P





This page, in questa pagina:
Erica '19,
sofas, divani - 9NE170

Erica '19, small armchairs
poltroncine - NE80P
Kyra, carpets, tappeti - TY200

Mirto Outdoor, small table, tavolino
TMO162_4
Frank Outdoor, ottoman, pouf - OF58P

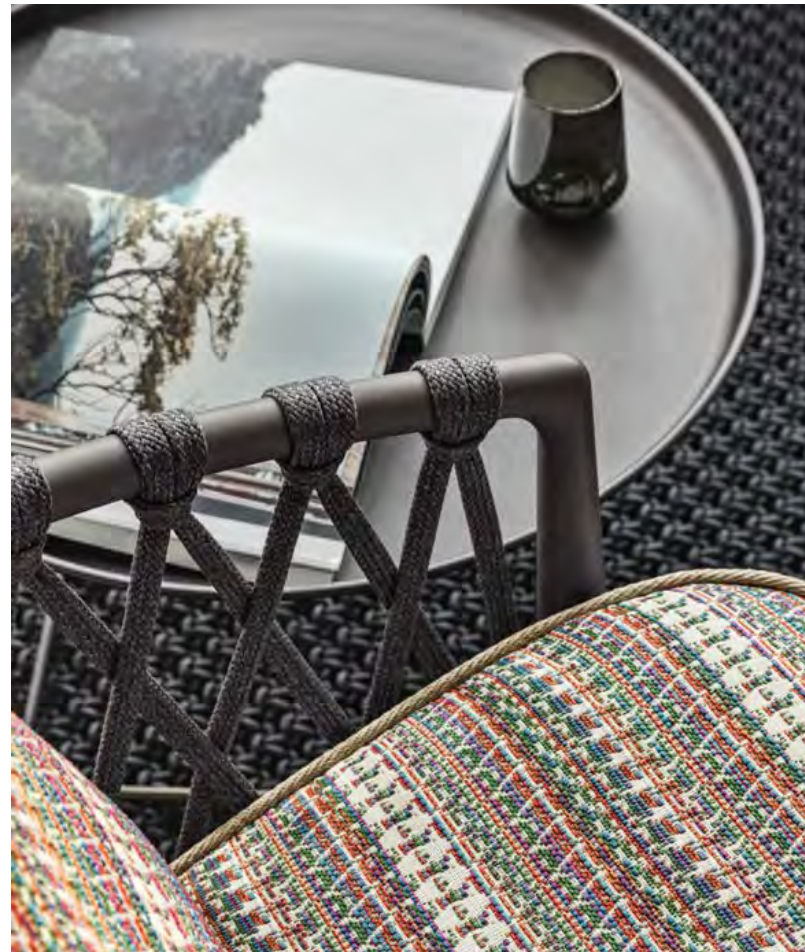

This page, in questa pagina:
Erica '19, small armchairs,
poltroncine - NE80P

Fat-Fat Outdoor, small table,
tavolino - OF62V
Kyra, carpets, tappeti - TY200

Opposite, nella pagina accanto
Erica '19, small armchairs poltroncine - NE80P
Erica '19, sofas, divani - 9NE170

Fat-Fat Outdoor, small table, tavolino - OF62
Fat-Fat Outdoor, small table, tavolino - OF42
Kyra, carpets, tappeti - TY200

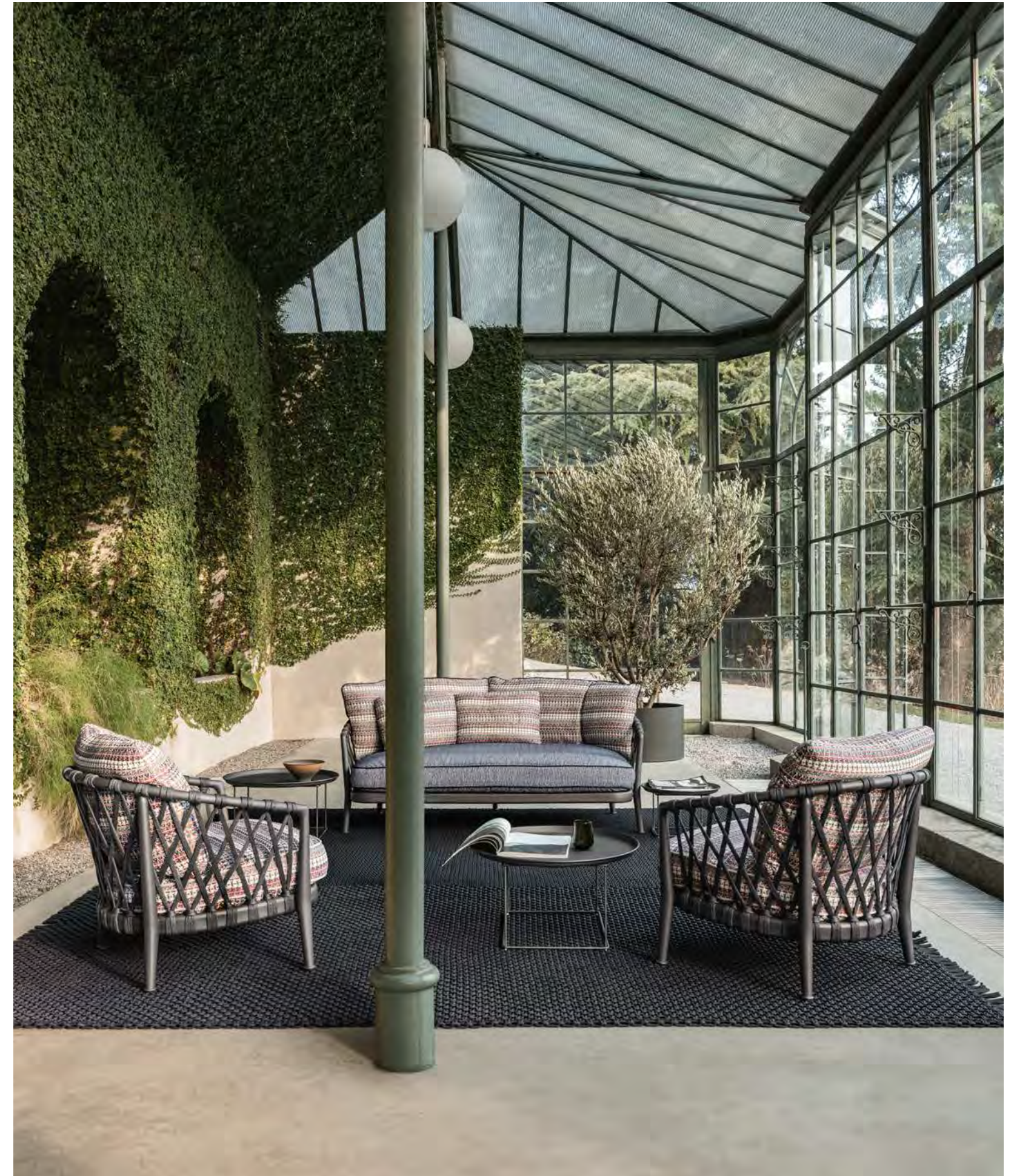

ENG

The unusual colour juxtaposition of frame and interlacing in anthracite, tortora or a frame in sage with natural-coloured interlacing can be complemented by a vast range of cushion covers, in an array of tones and designs, all co-ordinating with each other. There is also a chair with armrests with an brand new interlaced backrest.

ITA

Inediti gli accostamenti cromatici con struttura e intreccio antracite, tortora oppure con struttura salvia e intreccio naturale, da abbinare ad un'ampia gamma di rivestimenti per i cuscini proposti in numerose nuance e fantasie tra loro coordinabili. La proposta è completata dalla sedia con braccioli con un inedito intreccio per lo schienale.



This page, in questa pagina:
Erica' 19, stackable chairs,
sedie impilabili - NE61S_J

Opposite, nella pagina accanto
Mirto Outdoor, table,
tavolo - TMO222

Erica' 19, stackable chairs;
sedie impilabili - NE61S_J
Kyra, carpets, tappeti - TY200



ENG

Sofas, armchair, small armchair and chair, including a stackable version, offer a technological blend of extruded and die-cast aluminium elements. Their lightness and design makes them ideal for both public and residential settings, featuring seat and back cushions for ergonomic comfort together with strength for outdoor use. The painted frames are available in three finish combinations: white painted aluminium frame with tortora colour polypropylene fibre interlacing, tortora painted aluminium frame with tortora colour polypropylene fibre interlacing or anthracite painted aluminium frame with anthracite colour polypropylene fibre interlacing.

ITA

Divani, poltrona, poltroncina e sedia, anche in versione impilabile, sono studiati con un mix tecnologico di estrusi e pressofusioni di alluminio. La loro leggerezza e il loro disegno ne suggeriscono l'utilizzo sia in spazi pubblici che residenziali, rispettando criteri di ergonomia e adattabilità ambientale. I cuscini sedile e schienale garantiscono un confortevole relax. Tre le finiture delle strutture verniciate, abbinata ad intrecci di nastri in tessuto sintetico con un'anima interna ad alta tenacità studiata per l'utilizzo outdoor: struttura in alluminio verniciato bianco con intreccio in fibra di polipropilene tortora, struttura in alluminio verniciato tortora con intreccio in fibra di polipropilene tortora o struttura in alluminio verniciato antracite con intreccio in fibra di polipropilene antracite.

Erica,

the lightness and the design of the elements make them ideal for both public and residential settings, featuring set and back cushions for ergonomic comfort together with strength for outdoor use.

la leggerezza e il disegno degli elementi ne suggeriscono l'utilizzo sia in spazi pubblici che residenziali, rispettando criteri di ergonomia e adattabilità ambientale.







This page, in questa pagina:
Erica, small armchairs, poltroncine
E80P

Opposite, nella pagina accanto:
Erica, armchairs, poltrone
E90P



This page, in questa pagina:
Erica, chair, sedia
E61S

Erica, stackable chairs,
sedie impilabili
E61S_I

Opposite, nella pagina accanto:
Mirto Outdoor, table, tavolo - MI250TG
Erica, chairs, sedie - E61S

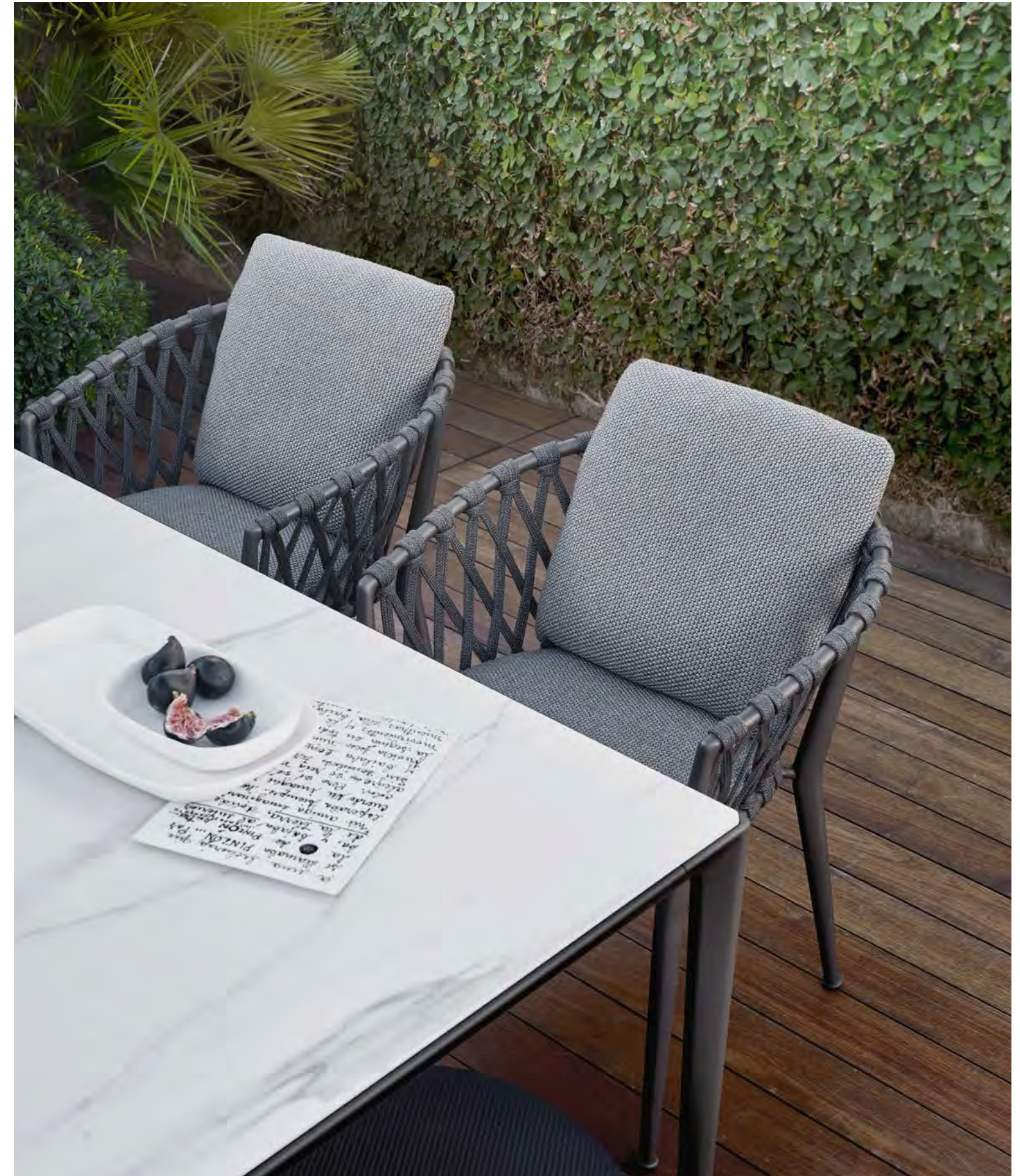

ENG

After its success indoors, the Ray seating system by Antonio Citterio now include two new outdoor versions, namely the "Natural" and "Fabric" collections of seats which stand out for their new interlacings and materials. Ray Outdoor Natural features an interlacing rope pattern reminiscent of Manila hemp, in perfect harmony with nature, and is created with textile, making it perfect for outdoor use. Ray Outdoor Natural is available with an extruded aluminium feet or teakwood base. The "Natural" collection consists of sofas available in two depths as well as modular elements such as terminal elements, chaise longue and armchair.

ITA

Dopo il successo in ambito indoor, il sistema di sedute Ray di Antonio Citterio si veste per l'outdoor con due famiglie di sedute, "Natural" e "Fabric" che si distinguono per differenti intrecci e materiali. La famiglia Ray Outdoor Natural è caratterizzata da un intreccio a "corda" che si rifà all'abaca naturale, in perfetta armonia con la natura, ed utilizza textilene perfettamente adatto agli ambienti esterni. Ray Outdoor Natural è disponibile sia con piedini in estruso d'alluminio che nella versione con basamento in teak. Le tipologie di seduta si compongono di divani in due profondità e di elementi componibili, dai terminali alle chaise longue, e poltrona.

Ray Outdoor Natural,

features an interlacing rope pattern reminiscent of Manila hemp, in perfect harmony with nature.

è caratterizzato da un intreccio a "corda" che si rifà all'abaca naturale, in perfetta armonia con la natura.







These pages, in queste pagine:
Ray Outdoor Natural, chaise longue - RN236LD_B

Ray Outdoor Natural, sofa, divano - RNL236_B
Twist, carpets, tappeti - TW300

Ray Outdoor Natural, armchairs,
poltrone - RN86_B

Gio, small table, tavolino - TGO18
Gio, small table, tavolino - TGO6

ENG

Ray Outdoor Fabric features an interlacing ribbon pattern, created using polypropylene fibre that are resistant to UV rays and weathering. The range of colours, particularly suitable for outdoor environments, varies from turquoise to blue and from acid green to tortora through to bright bordeaux. Ray Outdoor Fabric is available with extruded aluminium feet or teakwood base. The "Fabric" collection consist of sofas available in two depths as well as modular elements such as terminal elements or chaise longue, armchair and a sunbed with wheels.

ITA

Ray Outdoor Fabric si distingue per l'intreccio a nastro, realizzato in fibra di polipropilene resistente ai raggi UV ed agli agenti atmosferici. La gamma di colori, particolarmente adatta agli ambienti outdoor, varia dal turchese al blu, dal verde acido al tortora sino ad un vivo colore bordeaux. Ray Outdoor Fabric è disponibile sia con piedini in estruso d'alluminio che nella versione con basamento in teak. Le tipologie di seduta si compongono di divani in due profondità e di elementi componibili, dai terminali alle chaise longue, alla poltrona e al lettino con ruote.

Ray Outdoor Fabric,

features an interlacing ribbon pattern,
created using polypropylene fibre that are
resistant to UV rays and weathering.

si distingue per l'intreccio a nastro, realizzato
in fibra di polipropilene resistente ai raggi UV
ed agli agenti atmosferici.





These pages, in queste pagine:
Ray Outdoor Fabric, armchairs, poltrone - RF85_B

Ray Outdoor Fabric, modular sofa,
 divano componibile - RF235D_B - RF235LS_B

Gio, small table, tavolino - TGO12
Gio, small table, tavolino - TGO6

Fat-Sofa Outdoor, ottoman, pouf - FA61P
Kaleidos, carpets, tappeti - TKA300



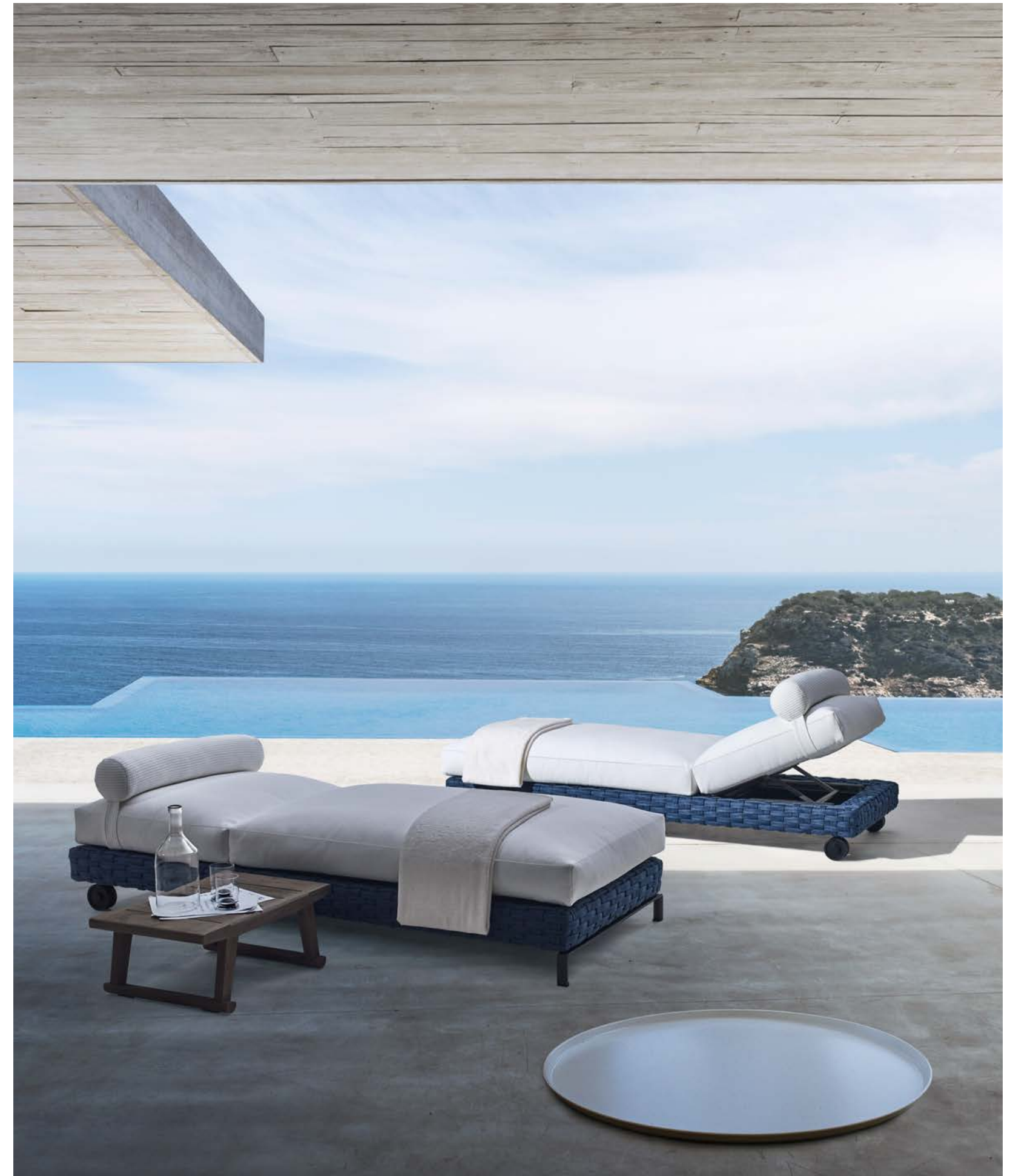

Opposite, nella pagina accanto:
Ray Outdoor Fabric, chaise longue - RF203LA

Gio, small table, tavolino - TGO6
Husk Outdoor, tray, vassoio - HTO62V

ENG

Gio, designed by Antonio Citterio, is the series with a contemporary classic accent dedicated to living in the open air. A complete range of sofas, end units, chaise longue, sunbeds, armchairs, chairs, tables and complements which have been developed from solid teak structures with a special antique grey finish, which gives the wood a particular lived-in aspect and silver-grey reflective quality.

The various types of sofas, end units and chaise longue can be assembled to form linear, corner and peninsula seating.

All elements have a basic structure of wooden slats where backrests and armrests, characterised by and interlacing of tortora ribbons, can be easily inserted. This particular type of structure allows for easily disassemble the various components, so to reduce the space needed to store the products in winter.

ITA

Al vivere all'aria aperta è dedicata Gio, la serie dall'accento classico contemporaneo disegnata da Antonio Citterio. Una famiglia completa di divani, elementi terminali, chaise longue, lettini, poltrone, sedie, tavoli e complementi che si sviluppano a partire da strutture in massello di teak nella speciale finitura antique grey, che conferisce al legno un particolare aspetto vissuto con riflessi grigio argento. Da un punto di vista formale le varie tipologie di divani, elementi terminali e chaise longue, tutti accostabili per formare sedute lineari, angolari e a penisola, prevedono una struttura di base a doghe di legno sulla quale si innestano telai schienale e braccioli caratterizzati dall'intreccio di nastri di colore tortora. Questa particolare tipologia di struttura consente di disassemblare in maniera molto semplice i vari componenti, riducendo così i volumi nel caso in cui si renda necessario stoccare il prodotto nel periodo invernale.

Gio,

the solid teak structure with a special antique grey finish, gives the wood a particular lived-in aspect and silver-grey reflective quality.

la struttura in massello di teak nella speciale finitura antique grey, conferisce al legno un particolare aspetto vissuto con riflessi grigio argento.







Opposite, nella pagina accanto:
Gio, modular sofa, divano componibile
GO233TD - GO197AD

This page, in questa pagina:
Gio, sofa, divano
GO238



These pages, in queste pagine:
Gio, modular sofa, divano componibile
GO233TD - GO197AD

Gio, armchairs, poltrone - GO64
Gio, bench, panca - GO130P
Gio, small table, tavolino - TGO12

Gio, small table, tavolino - TGO9
Twist, carpets, tappeti
TW300



ENG

The seats are equipped with seat and back cushions which makes the Gio series particularly cosy and comfortable, and offer exclusive colour combinations. To ensure a better insulation from the weather, all the padded elements have a polyester cover with waterproof treatment, and the fabrics are certified for resistance to weathering, UV rays, chlorine and sea spray.

ITA

Le sedute sono completate da cuscini sedile e schienale che rendono Gio particolarmente accogliente e confortevole e offrono esclusivi abbinamenti cromatici. Per garantire un migliore isolamento dalle intemperie, tutte le imbottiture sono rivestite con una fodera di poliestere con trattamento waterproof, mentre i tessuti sono certificati per resistenza agli agenti atmosferici, ai raggi UV, all'acqua clorata e alla salsedine.

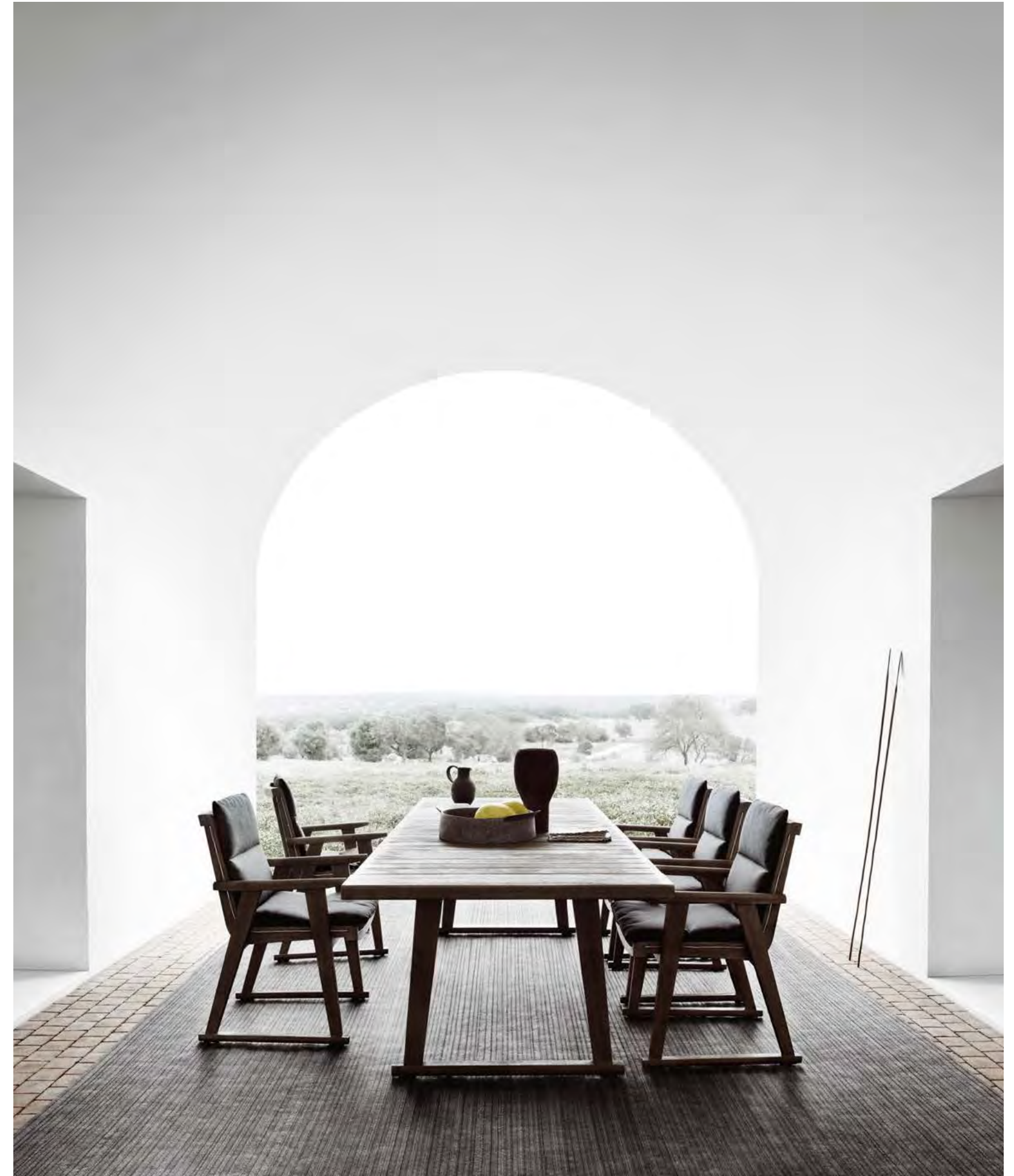

ENG

The Charles sofa system, a long-time bestseller for the company, is being introduced in an outdoor version: Charles Outdoor. Characteristics that made it a classic of pure contemporary taste have been left unchanged. The system will have the same slim frame, flexibility and signature design of the inverted "L" shape aluminium foot. The new piece maintains the beauty and simplicity of the original project while also evolving gracefully for practical outdoor use: the piece is lightweight thanks to its slim aluminium frame and has an external surface created by open interlacing brown polypropylene ribbon.

ITA

Il sistema di divani Charles, bestseller e longseller dell'azienda, viene proposto nella versione outdoor: Charles Outdoor. Rimangono inalterate le caratteristiche che lo hanno reso un classico dal gusto decisamente contemporaneo: la struttura sottile, la flessibilità del sistema e il design essenziale del piedino in alluminio a forma di "L" rovesciata. Sempre mantenendo un'estetica rigorosa e atemporale, equivalente al progetto iniziale, il volume di struttura si svuota grazie ad una struttura leggera di alluminio e a una superficie esterna realizzata con un intreccio aperto, regolare e ortogonale, di nastri in polipropilene marrone.

Charles Outdoor,

characteristics that made it a classic of pure contemporary taste have been left unchanged.

rimangono inalterate le caratteristiche che lo hanno reso un classico dal gusto decisamente contemporaneo.

Opposite, nella pagina accanto:
Charles Outdoor, modular sofa,
divano modulare - CHO160LS - CHO234D

*Reel, service element,
elemento di servizio
*Out of catalogue, fuori produzione





These pages, in queste pagine
Charles Outdoor, modular sofa,
 divano modulare - CHO160LS - CHO234D

Charles Outdoor, armchair, poltrona - CHO84
Springtime, small table, tavolino - TST7
Husk Outdoor, tray, vassoio - HTO62V

Reel, service element,
 elemento di servizio - RE130P
 *Out of catalogue, fuori produzione



This page, in questa pagina
Charles Outdoor, sofa, divano
CH0234





This page, in questa pagina:
Charles Outdoor, chaise longue
CH0202L

Opposite, nella pagina accanto:
Charles Outdoor, chaise longue
CH0202LA

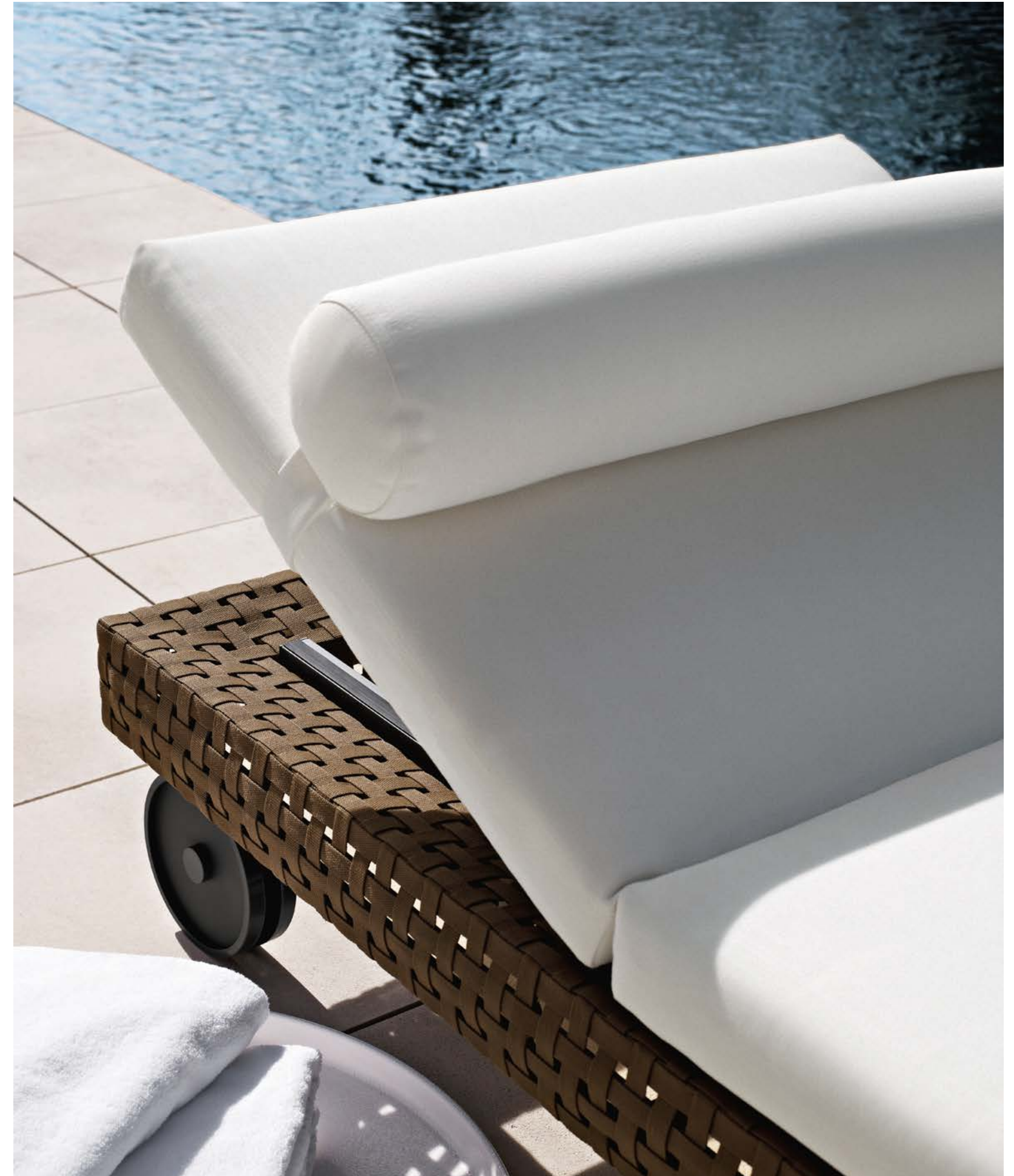

ENG

Collection of large rectangular and round dining tables featuring natural teakwood structural details and designed tops, studied to match central inserts made of Calacatta white porcelain stoneware.

The same collection features a chair, always in natural teakwood, with sinuous harmonious lines that are clearly inspired by northern trends. It is characterised by an interlacing in polypropylene fibre that is ideal for outdoor use. Colours are chosen to match natural teakwood with a beige interlacing. Comfort is guaranteed by seat and back cushions.

ITA

Collezione di tavoli da pranzo rettangolari e rotondi di grandi dimensioni caratterizzati da dettagli strutturali e disegni dei top realizzati in teak naturale che si abbinano ad inserti centrali realizzati in gres porcellanato bianco Calacatta. Della stessa serie una sedia, sempre in teak naturale, dalle linee sinuose e fluide di chiara ispirazione nordica, caratterizzata da un intreccio di nastri in tessuto sintetico adatto all'utilizzo outdoor. Lo studio cromatico ha previsto l'abbinamento del teak naturale ad un intreccio con nastro di colore beige. Il comfort è garantito da un cuscino sedile e schienale.

Ginestra,

sinuous harmonious lines clearly inspired by northern trends. It is characterised by an interlacing in polypropylene fibre that is ideal for outdoor use.

dalle linee sinuose e fluide di chiara ispirazione nordica, caratterizzata da un intreccio di nastri in tessuto sintetico adatto all'utilizzo outdoor.









This page, in questa pagina:
Ginestra, chairs, sedie - GN60

Opposite, pagina accanto:
Ginestra, table, tavolo - GN280T

Ginestra, chairs, sedie - GN60
Twist, carpets, tappeti - TW300



Gelso,

is characterized by slightly spindle-shaped die-cast aluminum legs and by a white back-painted etched glass top with a particular shape.

è caratterizzato da gambe in pressofusione di alluminio leggermente affusolate e da un top in vetro acidato retro-verniciato bianco con una particolare forma sagomata.



Frank Outdoor,

This outdoor ottomans have contrasting profiles matched to colourful outdoor fabrics to provide a touch of colour to your outdoor furnishings.

Pouf per esterni che si caratterizzano per l'abbinamento di profili a contrasto abbinati a colorati tessuti outdoor e che donano una nota di colore agli arredi per esterno.



ENG

After the debut in the home collection, Edward Barber and Jay Osgerby design Tobi-Ishi Outdoor, the outdoor version of the iconic round dining table and of the small table clearly inspired by Zen. The design duo are great enthusiasts of Japanese art and culture, and the name and inspiration come from the smooth stones "tobi-ishi" used as ornaments in traditional Zen gardens. The overhang of the table and the vertical trapezoidal bases set at right angles generate an essential sculptural figure that appears to change shape depending on the point of observation. Exclusively made of cement, Tobi-Ishi Outdoor comes in two colour variants, grey and anthracite.

ITA

Dopo il debutto nella collezione casa, Edward Barber e Jay Osgerby propongono Tobi-Ishi Outdoor, la versione da esterno dell'iconico tavolo da pranzo rotondo e del tavolino con esplicite ispirazioni zen. I due designer sono grandi estimatori dell'arte e della cultura giapponese ed il nome e l'ispirazione è un riferimento alle pietre levigate "tobi-ishi" usate con funzione ornamentale nei tradizionali giardini zen. Lo sbalzo del piano e le basi trapezoidali verticali poste ortogonalmente tra loro generano una figura scultorea ed essenziale, che varia costantemente la propria immagine secondo il punto di osservazione. Unica la finitura del tavolo e del tavolino, realizzati in cemento in due diverse varianti di colore, grigio ed antracite.

Tobi - Ishi Outdoor,

the name and inspiration come from the smooth stones "tobi-ishi" used as ornaments in traditional Zen gardens.

il nome e l'ispirazione è un riferimento alle pietre levigate "tobi-ishi" usate con funzione ornamentale nei tradizionali giardini zen.





This page, in questa pagina:
Tobi - Ishi Outdoor, small table, tavolino
OT146



ENG

Bay is a collection of sculptural and monolithic yet visually light outdoor seats comprising of a sofa in two sizes, an armchair and a high-backed armchair. Their enveloping volumes are marked by a double polypropylene fibre interlacing that creates "air pockets", granting transparency and lightness to the furniture. The frame accommodates padded solid seats and soft cushions for added comfort. The colours combinations are extremely refined, with tortora and anthracite for the interlacing, paired with elegant block colour and patterned fabrics for the seats and cushions.

ITA

Bay è una collezione di sedute da esterno composta da divano in due dimensioni, poltrona e poltrona con schienale alto, che si distinguono per l'aspetto scultoreo e monolitico, al contempo visivamente leggero. Avvolgenti volumi intrecciati realizzati in fibra di polipropilene, con un doppio intreccio che crea "tasche d'aria" che donano trasparenza e leggerezza, sono combinati con sedute imbottite dalle sembianze di rocce e si completano con morbidi cuscini che offrono grande comfort. Ricercata la proposta cromatica che prevede due colori per l'intreccio, tortora e antracite, da abbinare alle raffinate tonalità di tessuti tinta unita e fantasia previsti per i rivestimenti di sedute e cuscini.

Bay,

a collection of sculptural and monolithic yet visually light outdoor seats.

una collezione di sedute da esterno dall'aspetto scultoreo e monolitico, al contempo visivamente leggero.





Opposite, nella pagina accanto:
Bay, sofa, divano - BY236

Bay, armchairs with high back
poltrone con schienale alto - BY123A

Tabour Outdoor, ottoman, pouf - TBO2
Twist, carpets, tappeti - TW300

ENG

In 2019 the Bay collection has seen the addition of a sofa, a small armchair and an ottoman that reinforce the iconic image of the range by mirroring the generous and solid shapes and the sense of transparency generated by the interplay of anthracite-and dove-coloured polypropylene interlacing. The new sofa has a particularly welcoming and deep seat, complemented by soft seat-back cushions and new roller cushions that can be used as headrests. The small armchair is a scaled-down version of the existing armchair providing a perfect addition to the collection, or an alternative for smaller spaces. The new ottoman mirrors the chair design and coordinates with the whole range.

ITA

La collezione Bay si arricchisce nel 2019 di un divano, una poltroncina e un pouf che confermano l'iconicità della famiglia, riprendendone i volumi ampi e monolitici e le trasparenze create dai sofisticati giochi di intrecci in polipropilene antracite e tortora. Il nuovo divano presenta una seduta particolarmente accogliente e profonda, completata da morbidi cuscini schienale e dai nuovi cuscini rullo da utilizzare come poggiatesta. La poltroncina riproduce in scala ridotta le poltrone già in collezione, diventando così una perfetta aggiunta oppure un'alternativa per spazi più ridotti. Nuovo anche il pouf che riprende il disegno delle sedute e si coordina con tutti gli elementi della serie.



This page, in questa pagina:
Bay, armchair with low back
 poltrona con schienale basso - BY118B

Bay, armchair with high back
 poltrona con schienale alto - BY123A

Opposite, nella pagina accanto:
Bay, armchair with low back
 poltrona con schienale alto - BY123A

Bay, small armchair,
 poltroncina - BY94
Bay, ottoman, pouf - BY74PQ



This page, in questa pagina:
 Bay, sofa, divano - BY176CL
 Bay, small armchair, poltroncina - BY94

Bay, ottoman, pouf - BY74PQ
 Tobi-Ishi Outdoor, small table, tavolino - OT146
 Kyra, carpets, tappeti - TY200

Opposite, nella pagina accanto:
 Bay, sofa, divano - BY176CL
 Bay, small armchair, poltroncina - BY94

Bay, ottomans, pouf - BY74PQ
 Tobi-Ishi Outdoor, small table, tavolino - OT146
 Kyra, carpets, tappeti - TY200



ENG

After their success indoors, the Tabour ottomans now include new versions for use outdoors. These large, elongated, oval or square ottomans are multifunctional furnishings that can be used to create open-air conversation islands or to extend sofas and armchairs. The central, oversized "button", white, tortora or anthracite painted serves as a tray.

ITA

Dopo il successo in ambito indoor, i pouf Tabour ampliano le loro funzioni d'uso nel contesto outdoor. I grandi pouf di forma ovale allungata e quadrata, sono complementi polifunzionali che possono comporre arcipelaghi di conversazione all'aperto o diventare la naturale prosecuzione di divani e poltrone. Il "bottono" oversize centrale verniciato bianco, tortora o antracite ha la funzione di vassoio.



Tabour Outdoor,

these large, elongated, oval or square ottomans are a multifunctional furnishing.

i grandi pouf di forma ovale allungata e quadrata sono complementi polifunzionali.



ENG

Butterfly gets its name from the “butterfly” shape created by the outer corner that joins the armrest and the backrest. It is a modular seating system that responds effectively to the needs of modularity and comfort, suitable for free and informal usage. Its modular structure is shaped around an ottoman, which is the base piece, and which, when integrated with the backrest and/or the armrest, becomes a central or terminal element, either left or right. The combination of these elements, using a simple joint system, makes it possible to freely set up versatile configurations, from in-line sofas to corner solutions, from front facing to lounge layouts. The Butterfly complements have an outline that perfectly follows the lines of the sofa, harmoniously flanking the seat at the top. The family consists of round, square, and rectangular low tables and a small table featuring a large weave pattern, made of tortora coloured twisted polyethylene fibres that wraps around the grey painted aluminium frame. Two finishes are available for the surfaces of the complements: white Carrara marble “venatino statuarietto” or thermo-treated ash wooden slats.

Butterfly,

gets its name from the “butterfly” shape created by the outer corner that joins the armrest and the backrest.

prende il suo nome dalla forma a “farfalla” che disegna l’angolo esterno di unione tra bracciolo e schienale.

ITA

Butterfly prende il suo nome dalla forma a “farfalla” che disegna l’angolo esterno di unione tra bracciolo e schienale. È un sistema di sedute componibili che risponde in modo efficace ad esigenze di modularità e comfort, proponendo un utilizzo libero e informale. La struttura modulare si sviluppa intorno ad un pouf, il pezzo base, che integrato con schienale e/o bracciolo diventa poi un elemento centrale o terminale, destro o sinistro. Dall’accostamento tra questi elementi, tramite un semplice sistema di giunzione, nascono configurazioni libere e versatili, dai divani lineari a soluzioni angolari, da un accostamento vis-à-vis a soluzioni lounge. I complementi Butterfly presentano una silhouette che riprende perfettamente l’andamento della struttura del divano, affiancandosi poi armoniosamente alla seduta nella parte alta. La famiglia si compone di tavoli bassi di forma tonda, quadrata e rettangolare e da un tavolino caratterizzati da un intreccio grafico e dimensioni macro, realizzato con fibre di polietilene ritorte di color tortora, che avvolge la struttura in alluminio con finitura verniciata grigio. I piani dei complementi sono proposti in due finiture: marmo bianco di Carrara “venatino statuarietto” o in legno a doghe di frassino termotrattato.







These pages, in queste pagine:
Butterfly, modular sofa, divano componibile
BT112S - BT90C - BT90P - BT112D

Butterfly, ottomans, pouf - BT90P
Butterfly, small table, tavolino
BT15

Overscale Flames Outdoor,
oil candles, candele ad olio
AB20044B

ENG

The rounded, soft and sinuous shapes of the Fat-Sofa seating system are the base for the outdoor version, characterized by a brand new interlacing design. Its fully padded seat is accompanied by a metal frame backrest that supports the original weave, creating a special play of fullness and emptiness.

The large weave pattern, made of tortora coloured twisted polyethylene fibres, makes the design unique, respecting the designer's idea of lightness, transparency and puts the furnishings in an open "dialogue" with the surrounding environment. Fat-Sofa Outdoor consists of six types, ranging from the linear sofa to a large relax island, from two height variants of the armchair to a range of different sizes of ottomans.

ITA

Le forme arrotondate, morbide e sinuose, del sistema di sedute Fat-Sofa vengono riprese nella versione da esterni, caratterizzata da un'inedita proposta di intreccio. La seduta completamente imbottita è accompagnata ad uno schienale con struttura in metallo su cui si tesse l'originale intreccio, creando uno speciale gioco di pieni e vuoti. L'intreccio, di effetto grafico e dimensioni macro, realizzato con fibre di polietilene ritorte di color tortora, conferisce unicità al progetto, nel rispetto dell'idea della designer di leggerezza, trasparenza e "dialogo" dell'elemento di arredo con l'ambiente circostante. Fat-Sofa Outdoor si compone di sei tipologie, che spaziano dal divano lineare ad un'isola relax di ampie dimensioni, dalla poltrona con schienale in due altezze ad una serie di elementi pouf di diverse dimensioni.

Fat- Sofa Outdoor,

the rounded, soft and sinuous shapes of the Fat-Sofa seating system are the base for the outdoor version, characterized by a brand new interlacing design.

le forme arrotondate, morbide e sinuose del sistema di sedute Fat-Sofa vengono riprese nella versione da esterni, caratterizzata da un'inedita proposta di intreccio.





This page, in questa pagina:
Fat-Sofa Outdoor, armchair with high back
poltrona con schienale alto - FA91A

Fat-Sofa Outdoor,
ottoman, pouf
FA61P

Opposite, nella pagina accanto:
Fat-Sofa Outdoor, armchair with low back,
poltrona con schienale basso - FA91B

Fat-Sofa Outdoor,
ottoman, pouf
FA76P





ENG

A family of seating featuring a maxi-interlacing of white polyethylene fibre ribbon. There are many typologies: circular and linear sofas, armchairs, chairs, chaise longue and service elements. All these very comfortable seating have frames in aluminium with weather resistant polyester powder painting with interlacing in polyethylene fibre. The inspiration? A wicker basket in the Far East: Patricia Urquiola started working on the weave of Canasta (basket in Spanish) while out in the Far East. To find the perfect weave, the designer reinterpreted the traditional design of the octagonal holes in Viennese cane, mixed two patterns to transform the product into the macro-pattern of Canasta and create a series of outdoor sofas that look classic but have contemporary adaptability. In fact, the play between classic and contemporary is not a new idea: the Viennese cane inspiration is retro, and the polyethylene texture speaks today's language.

ITA

Famiglia di sedute caratterizzata dal macro-intreccio di nastri in fibra di polietilene bianca. Molteplici le tipologie: divani circolari e lineari, poltrone, sedie, chaise longue ed elementi di servizio. Tutte le sedute di grande comfort hanno la struttura in alluminio verniciato a polvere poliestere resistente agli agenti atmosferici e intreccio in fibra di polietilene. L'ispirazione? Una cesta in vimini vista in Estremo Oriente: Patricia Urquiola inizia da qui il lavoro sull'intreccio di Canasta (cesta, in spagnolo). Per trovare la trama perfetta la designer reinterpreta anche il tipico disegno a fori ottagonali della paglia di Vienna, mixa i due segni e li trasforma nel macro pattern geometrico di Canasta creando una serie di divani da giardino dalla memoria classica ma con plasticità contemporanea. Infatti il gioco tra il classico e il contemporaneo è senza alcuna nostalgia: se l'ispirazione alla paglia di Vienna è retro, la texture in polietilene parla il linguaggio di oggi.

Canasta,

the play between classic and contemporary is not a new idea: the Viennese cane inspiration is retro, and the polyethylene texture speaks today's language.

il gioco tra il classico e il contemporaneo è senza alcuna nostalgia: se l'ispirazione alla paglia di Vienna è retro, la texture in polietilene parla il linguaggio di oggi.

Opposite, nella pagina accanto:
Canasta, sofa with canopy and wheels,
divano con capote e ruote,
CN160P1 - CN160P1W - CN160P1C

Canasta '13, service element,
elemento di servizio - TCNC3
Canasta '13, service element,
elemento di servizio - TCN4

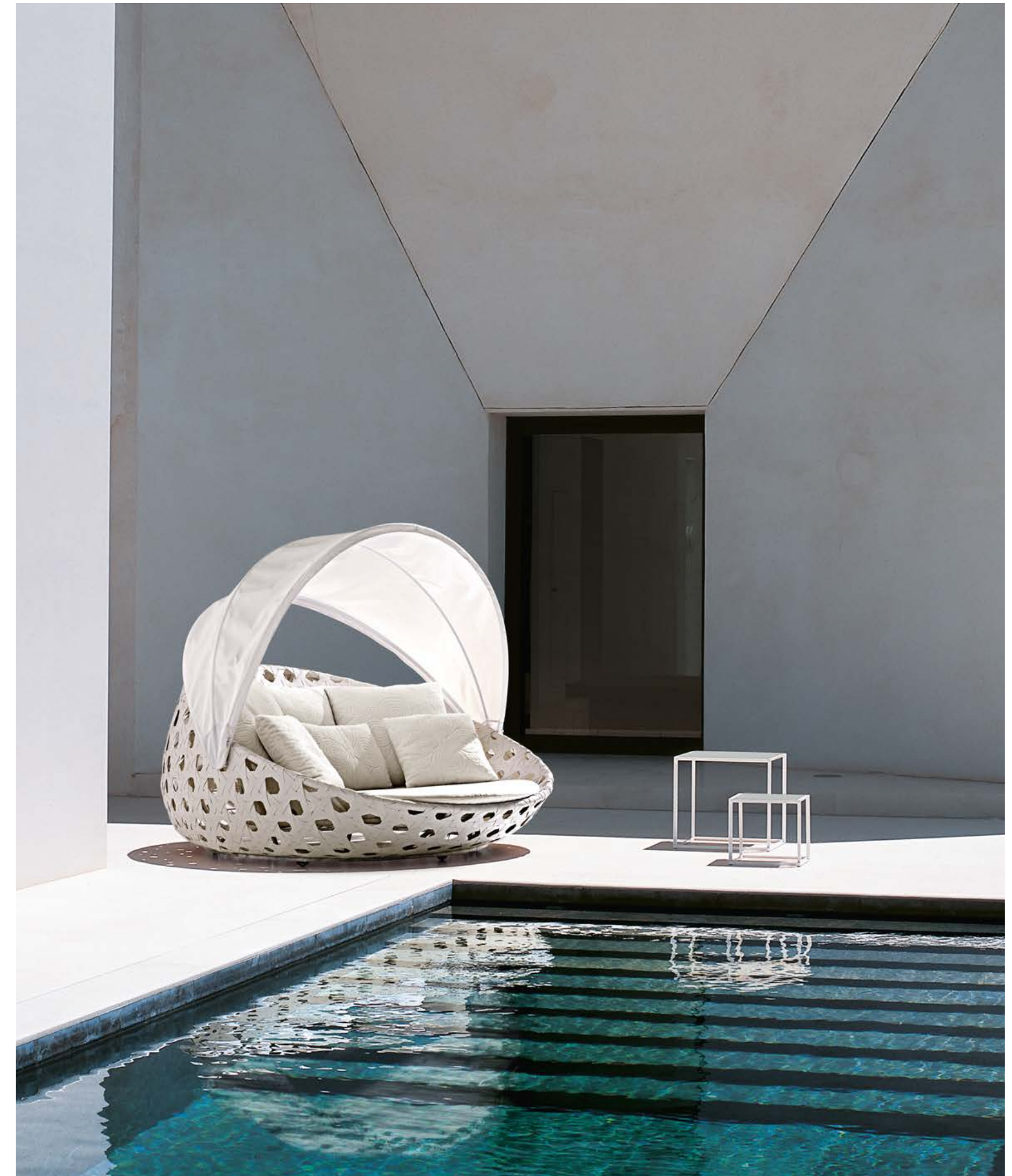



This page, in questa pagina:
Canasta, sofa with canopy and wheels,
divano con capote e ruote
CN160P1 - CN160P1W - CN160P1C

Opposite, nella pagina accanto
Canasta, sofa, divano - CN160P1





This page, in questa pagina:
Canasta, armchair with high back
poltrona con schienale alto - CN98PA

Canasta, armchair with low back,
poltrona con schienale basso
CN98PB





ENG

Outdoor sofas, swivel sofas, high and low back armchairs for the garden from the Canasta '13 collection maintain the iconic design and the typologies of the entire Canasta series, but with a new look designed to blend in with the external environment even more. The colours of the woven material become more natural, Tortora mélange, and the weave expands to let light and glimpses of the surroundings show through. Unique pieces, elegant outdoor furnishings that are super comfortable like the circular sofa with the swivel base, which lets you follow the sun and turn 360°.

ITA

I divani da esterno, divani girevoli, poltrone alte e basse da esterno della collezione Canasta '13 mantengono il design iconico e le tipologie di tutta la serie Canasta e cambiano "veste" per fondersi maggiormente con l'ambiente esterno. I colori dell'intreccio si fanno più naturali tingendosi di un tortora mélange e la trama dell'intreccio si dispiega lasciando trasparire la luce e l'ambiente circostante. Pezzi unici, protagonisti eleganti dell'arredamento da esterno e super confortevoli come il divano circolare oversize con la base girevole per seguire il sole a 360°.

Canasta '13,

the series maintain the iconic design and the typologies of the entire Canasta series, but with a new look designed to blend in with the external environment even more.

la serie mantiene il design iconico e le tipologie di tutta la serie Canasta e cambiano "veste" per fondersi maggiormente con l'ambiente esterno.

Opposite, nella pagina accanto:
Canasta '13, armchair with high back,
poltrona con schienale alto - CNC98PA

Canasta '13
service element,
elemento di servizio - PCNC60







This page, in questa pagina:
Canasta '13, sofa, divano
CNC160P1

Opposite, nella pagina accanto:
Canasta '13, sofa with canopy,
divano con capote CNC160P1 - CNC160P1C



ENG

The Canasta collection includes tables and service elements in different sizes. The tables frames are in aluminium and the service elements frames are in steel. Both frames are painted with weather resistant polyester powder. The tops are covered with exclusive tiles with decorative patterns. Nature is undoubtedly the inspiration behind the choices of colours and materials for the table Canasta '13. The cement coloured porcelain stoneware characterized the top of Canasta '13 tables and small tables. This look conveys timelessness and essential elegance.

ITA

La collezione Canasta si completa di tavoli ed elementi di servizio in diverse dimensioni. I tavoli hanno la struttura in alluminio mentre gli elementi di servizio in acciaio. Entrambe le strutture sono verniciate a polvere poliestere resistente agli agenti atmosferici e piani rivestiti con piastrelle esclusive con motivi decorativi. Evidenti sono i richiami alla natura che hanno guidato le scelte cromatiche e materiche per il tavolo Canasta '13. La finitura in cemento color porcellana caratterizza il piano dei tavoli e dei tavolini Canasta '13. Questa veste conferisce un'eleganza sobria e senza tempo.

Canasta Tables,

nature is undoubtedly the inspiration behind the choices of colours and materials.

evidenti sono i richiami alla natura che hanno guidato le scelte cromatiche e materiche.





This page, in questa pagina:
Canasta, service element,
elemento di servizio - TCN3

Canasta, service element,
elemento di servizio
TCN12

Canasta '13, service element,
elemento di servizio
TCN3

Canasta '13, service element,
elemento di servizio
TCN4







Opposite, nella pagina accanto:
Canasta '13, service element,
elemento di servizio - TCNC3

Canasta '13, service element,
elemento di servizio
TCNC4

ENG

Can you picture the dresses that women wore in the 1800s? Full, bell-shaped skirts held by crinolines (rigid underskirt garments) were spectacular “micro-architectures” commonly seen in living rooms everywhere. All of the chairs in the Crinoline collection are designed to reflect this elegant look: the wide curve of the base is repeated in the seat and the curve of the backrest.

Armchairs, small armchairs, chairs and a stool are designed in several different shapes and heights. The polyethylene fibre interlacing are joined by natural or bronze abaca. Being a natural material, the product with abaca interlacing is suitable for indoors, covered outdoor spaces or verandas.

ITA

Avete presente le gonne delle dame ottocentesche? Gonfie, a campana, sostenute dalle crinoline (sottogonne rigide) erano scenografiche micro-architetture da salotto. “Più che romantica. Più che sensuale. L'ispirazione è esotica e erotica”, dice Patricia Urquiola. Le poltrone e sedie Crinoline sono vestite in abito di gala: l'ampia conca della base ripresa nella seduta e nella curvatura dello schienale. Sedie, uno sgabello, poltroncine e poltrone sono declinate in tipologie diverse per forma e altezza. Ad intrecci in fibra di polietilene, si affiancano quelli in abaca naturale o bronzo. Il prodotto con intreccio in abaca naturale, trattandosi di fibra naturale, è destinato all'utilizzo in ambienti interni, in esterni coperti o verande.

Crinoline,

can you picture the dresses that women wore in the 1800s? Full, bell-shaped skirts held by crinolines (rigid underskirt garments) were spectacular “micro-architectures”.

avete presente le gonne delle dame ottocentesche? Gonfie, a campana, sostenute dalle crinoline (sottogonne rigide) erano scenografiche micro-architetture da salotto.

Opposite, nella pagina accanto:
Crinoline, armchairs, poltrone - C5P
Fat-sofa Outdoor, ottoman, pouf - FA61P





This page, in questa pagina:
Crinoline, armchair, poltrona - CSP

Opposite, nella pagina accanto:
Crinoline, armchair, poltrona - CSC





ENG

The table reflects the style of the Crinoline series, with a curved shape like the seats and the interlacing in polyethylene fibre.
The base is made of two connected elements that create a chalice shape that supports the tops, which are made of white glass or white full color HPL laminate with milled grooves in a radial pattern.
This last version is designed to hold a beach umbrella in the centre.

ITA

Coerente con la serie Crinoline, il tavolo riprende le forme curve che caratterizzano le sedute e l'intreccio in fibra di polietilene.
La base si compone di due elementi uniti che creano una forma a calice che supporta i piani, realizzati in vetro bianco o in laminato HPL full color bianco con fresatura passanti a raggiera.
Quest'ultima versione è predisposta per ospitare al centro un ombrellone.





This page, in questa pagina:
Crinoline, high stool, sgabello alto - C6PF
Crinoline, low stool, sgabello basso - C7PF

Opposite, nella pagina accanto:
Crinoline, chair with armrests,
sedia con braccioli - C2PF

Crinoline,
chair, sedia
C1PF

ENG

Comfort and eco-sustainability are the key words for describing Husk Outdoor, designed by Patricia Urquiola. The collection is a tribute to softness, and just looking at these pieces is restful. Husk Outdoor features a hard shell made of Hirek®, a special plastic formed from recycled and recyclable polymers, and a set of soft cushions. The shell is white, while the fixed seat support is available painted in five colours. Cushions come in two versions, with larger sizes on the seat or on the back.

Husk Outdoor,

the collection is a tribute to softness,
and just looking at these pieces is restful.

la collezione è un inno alla morbidezza
e invita al riposo già al primo sguardo.

Opposite, nella pagina accanto:
Husk Outdoor, armchair with snug sides,
poltrona con schienale avvolgente - H2

Husk Outdoor, armchair with armrests,
poltrona con braccioli - H4
Husk Outdoor, small table, tavolino - HT

ITA

Comfort ed ecosostenibilità le parole chiave delle poltrone Husk Outdoor disegnate da Patricia Urquiola. La collezione è un inno alla morbidezza e invita al riposo già al primo sguardo. Husk Outdoor si caratterizza per una scocca rigida in Hirek®, una speciale plastica formata da polimeri riciclati e riciclabili, ed una serie di cuscini soffici. Bianco è il colore della scocca, mentre il supporto fisso è disponibile verniciato in cinque varianti. Due le versioni della cuscineria, a scelta di dimensioni più generose sulla seduta o sullo schienale.





This page, in questa pagina:
Husk Outdoor, armchair with snug sides,
poltrona con schienale avvolgente - H2

Husk Outdoor,
armchair with armrests,
poltrona con braccioli - H4

Opposite, nella pagina accanto:
Husk Outdoor, armchairs with snug sides
poltrone con schienale avvolgente - H2





ENG

The Husk Outdoor collection also includes two small tables: one with three spokes \varnothing 45 cm, available in the same colour variants as the armchair bases; the other with four spokes \varnothing 62,5 cm, already proposed in indoor spaces, joins the Outdoor collection with single colour versions painted white or black.

ITA

Della collezione Husk Outdoor fanno parte anche due tavolini: uno a tre razze \varnothing 45 cm, disponibile nelle stesse varianti di colore dei basamenti delle poltrone; l'altro a quattro razze \varnothing 62,5 cm, già proposto per spazi indoor, entra a far parte della collezione Outdoor con le versioni monocolor verniciato bianco o nero.

ENG

A fisherman's work, the sea and its fragrance. A humble fishing net and its diamond-shaped weave. This is what inspired Patricia Urquiola to create the pattern of the woven material for Ravel. She worked until she arrived at the complex pattern that decorates the backrests of the pieces in the collection. The result of field experimentation in the field, Patricia Urquiola's work marks another visitation of the interlacing theme. Interlaced backs in polyethylene fibre matched with base in black or white galvanized steel with polyester powder painting produce a modular element of two different sizes. The pieces can be easily combined to form linear, corner, terminal elements or chaise longue. The ottoman-small table pieces can be used between seats, or to add depth to sofas.

ITA

Il lavoro dei pescatori, il mare e il suo profumo. Una umile rete da pesca ed il suo intreccio a losanga. Qui Patricia Urquiola si ispira per elaborare la trama dell'intreccio di Ravel, fino a ottenere il pattern complesso, che disegna gli schienali della collezione. Frutto di una sperimentazione avvenuta sul campo, il lavoro di Patricia Urquiola segna un ulteriore approfondimento del tema dell'intreccio. Schienali intrecciati in fibra di polietilene si abbinano a una base in acciaio zincato nero o bianco verniciato a polvere poliestere, producendo un elemento modulare di due diverse dimensioni, accostabile con estrema libertà a formare sedute lineari, angolari, terminali o chaise longue. Elementi pouf-tavolino possono essere utilizzati sia a intervallare le sedute, sia ad alimentarne la profondità.

Ravel,

is a modular sofa that meets the needs of an “open door” environment with several possible compositions and great versatility.

rappresenta il divano modulare che risponde alle esigenze di un ambiente “open door” con numerose possibilità compositive e grande versatilità d'uso.

Opposite, nella pagina accanto:
Ravel, modular sofa, divano componibile
R150S - R100A1S - R160A3D - R150P

Ravel, service element,
elemento di servizio - TR90
Husk Outdoor, tray, vassoio - HT062V

White Collection,
vase, vaso
AB20046B





Fat-Fat Outdoor,

the concept of a tray helped create three small outdoor tables with steel frames that give them a lightweight look. These small tables are entirely painted or with tops in porcelain stoneware.

il tema del vassoio viene ripreso per dar vita a tre tavolini per esterni il cui aspetto leggero è merito della struttura in acciaio. I tavolini sono proposti interamente verniciati oppure con piano in gres porcellanato.

Opposite, nella pagina accanto:
Fat-Fat Outdoor, small table, tavolino - OTF42
Kyra, carpet, tappeto - TY200

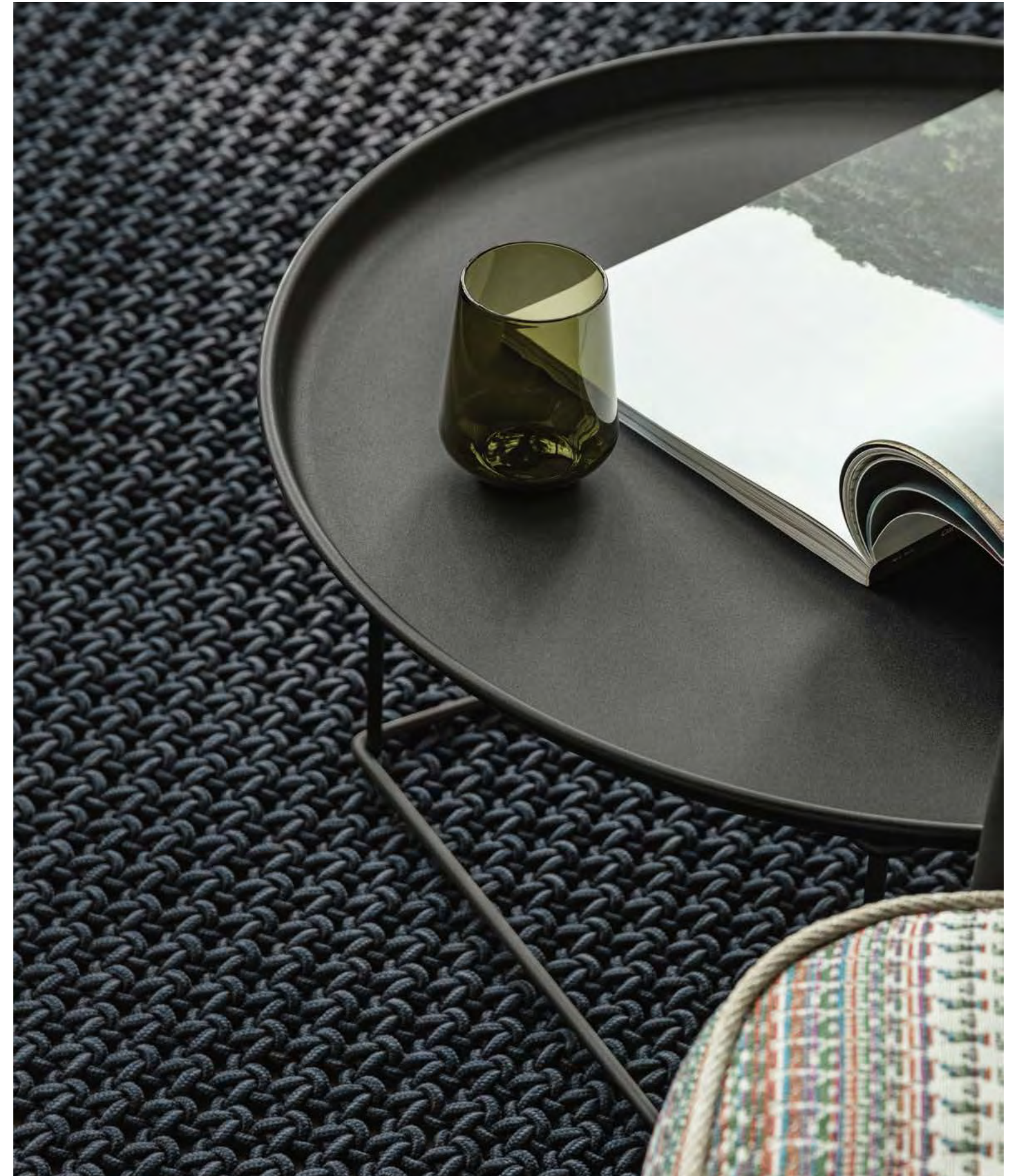



This page, in questa pagina:
Fat-Fat Outdoor,
small table, tavolino - OTF92G

Fat-Fat Outdoor,
small table, tavolino
OTF62G

Fat-Fat Outdoor,
small table,tavolino
OTF42G

Fat-Fat Outdoor,
small table, tavolino
OTF62AG

ENG

Fiore is a collection of dining tables with small sizes and small tables that stand out for their perfect formal balance and for the striking texture of their cement finish, available in white or greige. "Many years ago, I called my chairs Papilio because their silhouettes reminded me of butterflies. Now I have called my latest project Fiore, or flower in Italian, because the Papilio Shell chairs sit around these tables like butterflies flying around a flower. The combination of a Fiore table with the Papilio chairs creates a pleasant outdoor environment for a coffee or a quick meal. This was made possible by the use of a special cement moulding technology. We also added pigments so as to match the tables to the shell of the Papilio Shell chairs." (Naoto Fukasawa)

Fiore,

I have called my latest project Fiore, or flower in Italian, because the Papilio Shell chairs sit around these tables like butterflies flying around a flower.

ho chiamato questo nuovo tavolo Fiore, perché è un tavolo a cui le Papilio Shell stanno intorno come le farfalle volano intorno al fiore.

ITA

Una collezione di tavoli da pranzo di piccole dimensioni e di tavolini che si caratterizzano per il perfetto equilibrio formale e la forte matericità della finitura in cemento, in due varianti colore, greige e bianco. "Molti anni fa ho chiamato le mie sedie Papilio, perché la loro silhouette evocava le farfalle. Ora ho chiamato questo nuovo tavolo Fiore, perché è un tavolo a cui le Papilio Shell stanno intorno come le farfalle volano intorno al fiore. Credo che questa introduzione di Fiore insieme alle sedie Papilio crei un bell'ambiente outdoor per un caffè o un pasto veloce. Ciò è stato possibile grazie all'utilizzo di una tecnologia di stampo in cemento. Abbiamo aggiunto anche i pigmenti corretti per l'abbinamento con i colori delle scocche delle Papilio Shell." (Naoto Fukasawa)





Papilio Shell Outdoor,

is linked through its name to the previous family of very successful chairs and armchairs, but has an independent history.

Originating from a shell with a design that enhance comfort, it expresses considerable versatility that makes it perfect in different situations.

cita con il suo nome una precedente famiglia di sedute di grande successo, ma ha una storia indipendente. Originata da una scocca, il cui disegno sottolinea l'accoglienza e la comodità, esprime una notevole versatilità che la rende utilizzabile in situazioni molto diverse tra loro.



ENG

The waters of Lake Titikaka dictate the shape (and name) of the bench by Fukasawa. This stretch of water lies between Bolivia and Perú, a lake 204 km long and 65 km wide that occupies around 8562 km². This very beautiful place caught the designer's attention, and he tried to capture the movement of the waves to "move" the bench into a new, wavy shape. Titikaka revolutionises the concept of a bench. The traditional typology of the outdoor bench is revamped with contemporary language. It's an impressive piece that resembles a sculpture. Made of teakwood slats that cover the structure to the ground on both front and back, positioned horizontally on the aluminium structure in an original wave-like arrangement to create curves that are both pleasant and ergonomically functional.

ITA

Le acque del lago Titikaka dettano la forma (e il nome) della panca firmata Fukasawa. Tra Bolivia e Perú, il bacino di 204 km di lunghezza per 65 di larghezza occupa un'area di 8.562 km². Il luogo di grande suggestione ha colpito la fantasia del designer, che ha cercato di catturare il movimento delle onde per "muovere" la panca dall'inedito andamento ondulatorio. Titikaka rivoluziona il concetto di panchina. Ripropone la tradizionale tipologia della panca per esterni con linguaggio contemporaneo e si impone per la sua presenza scultorea. È realizzata in listelli di teak che scendono a terra su entrambi i fronti e si distribuiscono intorno alla struttura in alluminio con un originale andamento ondulatorio creando curve insieme plastiche e funzionali all'ergonomia della seduta.

Titikaka,

revolutionises the concept of a bench. The traditional typology of the outdoor bench is revamped with contemporary language. It's an impressive piece that resembles a sculpture.

rivoluziona il concetto di panchina. Ripropone la tradizionale tipologia della panca per esterni con linguaggio contemporaneo e si impone per la sua presenza scultorea.





Opposite, nella pagina accanto:
Titikaka, bench, panca - TK

ENG

A sculptural project by Naoto Fukasawa: the small table Awa Outdoor is a versatile object that can be used as a base for a lot of things. Base and top are integrated: aesthetically, it's the epitome of essential elegance. Awa is made with a technologically advanced material, a special blend of white Cristalplant Outdoor® that ensures it can be used both indoors and outdoors. Its particular surface is very soft, similar to natural stone.

ITA

Scultoreo progetto di Naoto Fukasawa: il tavolino Awa Outdoor è un oggetto versatile, di servizio, indispensabile per l'appoggio. Base e piano sono un unicum: l'estetica si divide tra l'eleganza e l'essenzialità. Il materiale è tecnologicamente avanzato: lo compone una speciale miscela in Cristalplant Outdoor® bianco che assicura l'utilizzo in indoor così come in outdoor. La particolare superficie del materiale ha un effetto soft touch, simile alla pietra naturale.

Awa Outdoor,

base and top are integrated: aesthetically,
it's the epitome of essential elegance.

base e piano sono un unicum:
l'estetica si divide tra l'eleganza e l'essenzialità.



ENG

One-of-a-kind, this piece has been moulded in a continuous, joint-free shape: Link Outdoor stands out for its “soft” material and sensual shape. The material makes you want to reach out and touch its smooth surface. An interestingly shaped dining table dominates the room: Danish designer Jakob Wagner places his pure, contemporary mark on this room, typical of northern design. The table is made in a single piece and there are no hooks or joints. Made from a practical technological material: a special type of Cristalplant Outdoor® ensures that it is suitable for outdoor use. It is a resin, in a fluid form that is moulded into the desired shape, a concept in line with B&B Italia's production philosophy for upholstered furniture. Cristalplant Outdoor® has a velvety smooth surface, an effective soft-touch surface that feels wonderful.

Link Outdoor,

stands out for its “soft” material and sensual shape. The material makes you want to reach out and touch its smooth surface.

si distingue per la sua matericità “morbida”, per la sensualità della sua forma e del suo materiale che suscitano il desiderio di sfiorarne la superficie levigata.

Opposite, nella pagina accanto:
Link Outdoor, table, tavolo - TLK250N
Twist, carpets, tappeti - TW300

*Mini Papilio Outdoor,
small armchair, poltroncina
*Out of catalogue, fuori produzione

ITA

Pezzo unico, plasmato, continuo, privo di giunti: Link Outdoor si distingue per la sua matericità “morbida”, per la sensualità della sua forma e del suo materiale che suscitano il desiderio di sfiorarne la superficie levigata. Un tavolo da pranzo sinuoso, plastico, protagonista dello spazio: lo firma il designer danese Jakob Wagner che ci mette il suo segno purissimo e contemporaneo, tipico del design nordico. Il tavolo è realizzato in un unico stampo e non prevede l'utilizzo di agganci e giunture. Tecnologico e pratico il materiale che lo compone: una speciale miscela in Cristalplant Outdoor® che assicura l'utilizzo da esterni e da interno. La resina, è in forma fluida e viene lavorata con stampi, concetto in linea con la filosofia di produzione degli imbottiti di B&B Italia. Al tatto Cristalplant Outdoor® si caratterizza per la superficie vellutata con effetto soft-touch di notevole impatto sensoriale.





Cosmos Outdoor,

this collection includes harmonious minimal tables and small tables, which can be used in pairs or groups of three due to their compact size.

una collezione di armoniosi e minimali tavoli e tavolini, che grazie alle dimensioni contenute si possono accostare l'uno all'altro adattandosi facilmente ad usi diversi.





ENG

Jean-Marie Massaud designed the Springtime Collection to furnish outdoor areas by creating a dialogue between nature and interior spaces. The combination of elements completes a domestic landscape that integrates this space and makes it liveable. Jean-Marie Massaud perceives the outdoors to be an infinite space in which there is dialogue, a harmonious relationship with nature and simultaneously a level of intimacy between ourselves and the people surrounding us. The collection is made up of sofas and chaise longue with white polyester powder painted aluminium frames. The pieces have stainless steel feet, polyester fibre upholstery and cover in water-repellent fabrics. The chaise longue comes in two different models: single with wheels or double with reclining headrests to place parallel or face to face, also with the possibility of placing support elements between the two seats. A rectangular small table with mahogany top can also be outfitted with cushion. The collection comes with several complements realized in white Cristalplant Outdoor®.

Springtime,

the combination of elements completes a domestic landscape that integrates this space and makes it liveable.

l'insieme disegna un paesaggio domestico che si integra nello spazio, abitandolo.

Opposite, nella pagina accanto
Springtime, chaise longue
ST100CHAW

Springtime, double chaise longue,
chaise longue doppia
ST170CH_4AW

ITA

Jean-Marie Massaud con la collezione Springtime punta ad arredare la natura cercando un dialogo tra il dentro e il fuori. L'insieme disegna un paesaggio domestico che si integra nello spazio, abitandolo. Jean-Marie Massaud percepisce l'ambiente esterno come uno spazio infinito nel quale desidera proporre un dialogo, una relazione armoniosa con la natura ed allo stesso tempo una intimità tra sé stessi e con le persone circostanti. La collezione si compone di divani e chaise longue con struttura in alluminio verniciato bianco a polvere poliestere, dotati di piedini in acciaio inox, imbottitura in fibra di poliestere e rivestimento in tessuto idrorepellente. Le chaise longue si presentano in due versioni: singole con ruote oppure doppie con i poggiatesta inclinabili da disporre paralleli o vis à vis e con la possibilità di posizionare elementi d'appoggio tra le sedute. Ulteriori tavolini rettangolari, con piani in mogano, accompagnano le sedute e possono essere dotati di cuscinate. La collezione si completa con diversi complementi realizzati in Cristalplant Outdoor® bianco.

Springtime, small tables, tavolini - TST200A
Springtime, service element,
elemento di servizio - ST

Overscale Flames Outdoor, oil candle,
candela ad olio
AB20044B





This page, in questa pagina:
Springtime, double chaise longue,
 chaise longue doppia - ST170CH_4AW
Springtime, service element,
 elemento di servizio - ST

Opposite, nella pagina accanto:
Springtime, chaise longue - ST100CHAW
Springtime, small table, tavolino - TST200A
Springtime, double chaise longue,
 chaise longue doppia - ST170CH_4AW

Springtime, service element,
 elemento di servizio - ST





This page, in questa pagina:
Springtime, sofa and canopy with drapes
divano e baldacchino con tenda
ST266_14AW - STT

Opposite, nella pagina accanto:
Springtime, sofa, divano - ST266_14AW
Springtime, small table, tavolino - TST200A
Husk Outdoor, tray, vassoio - HTO62V





These pages, in queste pagine:
Springtime, small tables, tavolini - TST4

Springtime, small tables, tavolini - TST7
Springtime, vase, vaso - TST11

Overscale Flames Outdoor,

the large oil candles designed by Jean-Marie Massaud are in high density polyurethane resin (Baydur[®]), with a metallic frame painted matt white.

le grandi candele a olio disegnate da Jean-Marie Massaud sono in resina poliuretana ad alta densità (Baydur[®]), con struttura metallica verniciata bianca opaca.

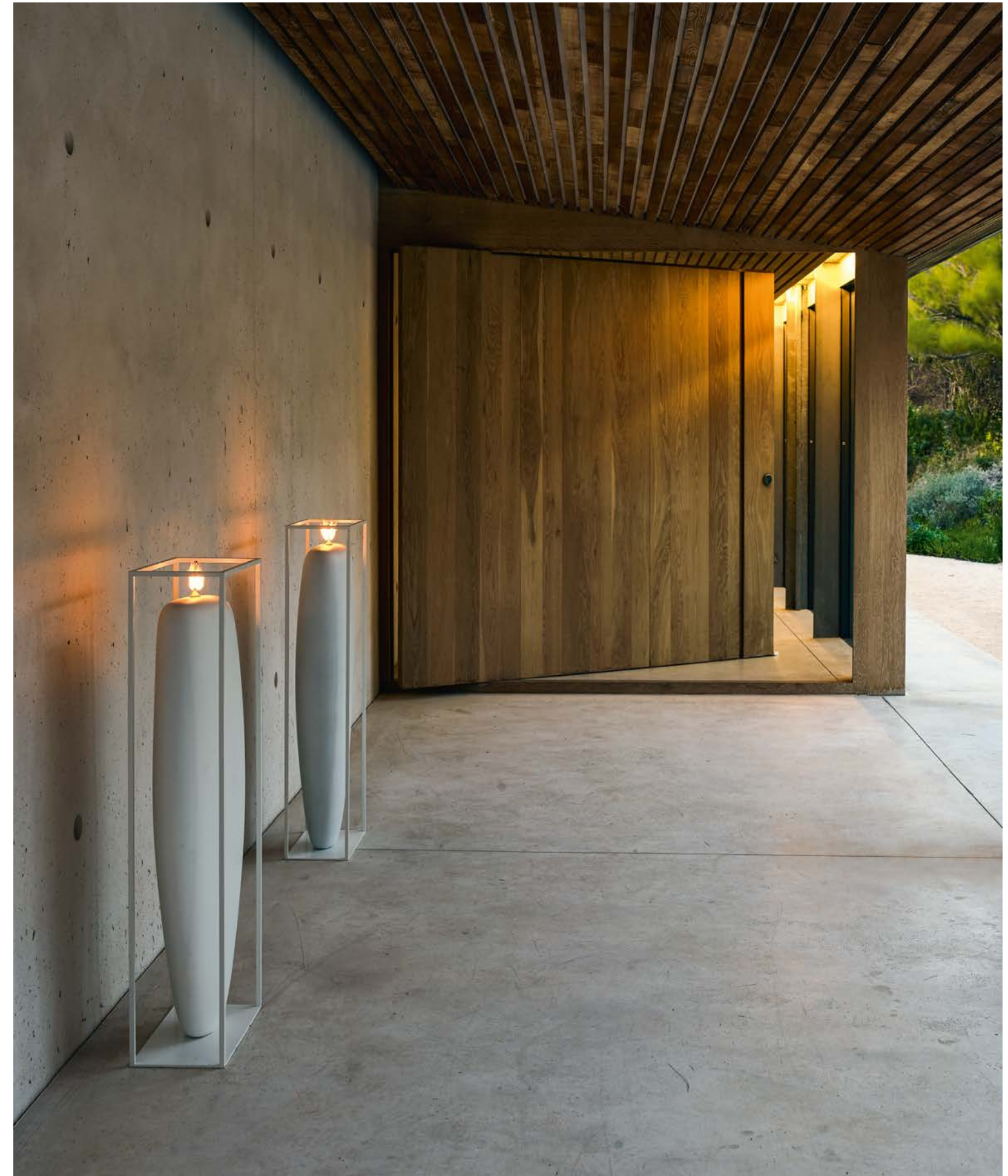



White Collection,

the Gold Collection by Marcel Wanders is available in the white version: vases and stool are in ceramic, also suitable for outdoor use.

la Gold Collection firmata da Marcel Wanders viene proposta in versione bianca: vasi e sgabello sono in ceramica, adatta anche per esterno.





ENG

The outdoor collection is further enriched by the new carpets. Specifically designed for outdoor use, marked by permeability and breathability, they are produced in polyolefin and come in various sizes.

Twist features a pattern of intertwined strips in six sophisticated block colours: rope, green, tortora, grey, anthracite, blue.

The multi-coloured blend of Kaleidos, instead, matches perfectly with the hues of the outdoor collection.

Kyra carpets are made entirely by hand in a single size (300 x 200 cm) and they come in different colours: stone, olive green, overseas blue, blue royal, violet or anthracite.

ITA

I tappeti contribuiscono ad arricchire la proposta di complementi per l'outdoor. Studiati appositamente per l'utilizzo all'aperto con caratteristiche di permeabilità e traspirabilità, sono realizzati in Poliolefine, e proposti in varie dimensioni.

Twist presenta un motivo a fasce intrecciate monocolori in sei sofisticate tonalità tinta unita: corda, verde, tortora, grigio, antracite, blu.

Kaleidos propone invece un melange multicolore che si coordina perfettamente con le cromie della collezione outdoor.

I tappeti Kyra sono realizzati interamente a mano in un'unica dimensione (cm 300 x 200), e sono proposti in differenti tonalità di colori: sasso, verde oliva, blu oltremare, blu royal, viola o antracite.

Twist, Kaleidos, Kyra

specifically designed for outdoor use, marked by permeability and breathability

studiati appositamente per l'utilizzo all'aperto con caratteristiche di permeabilità e traspirabilità.



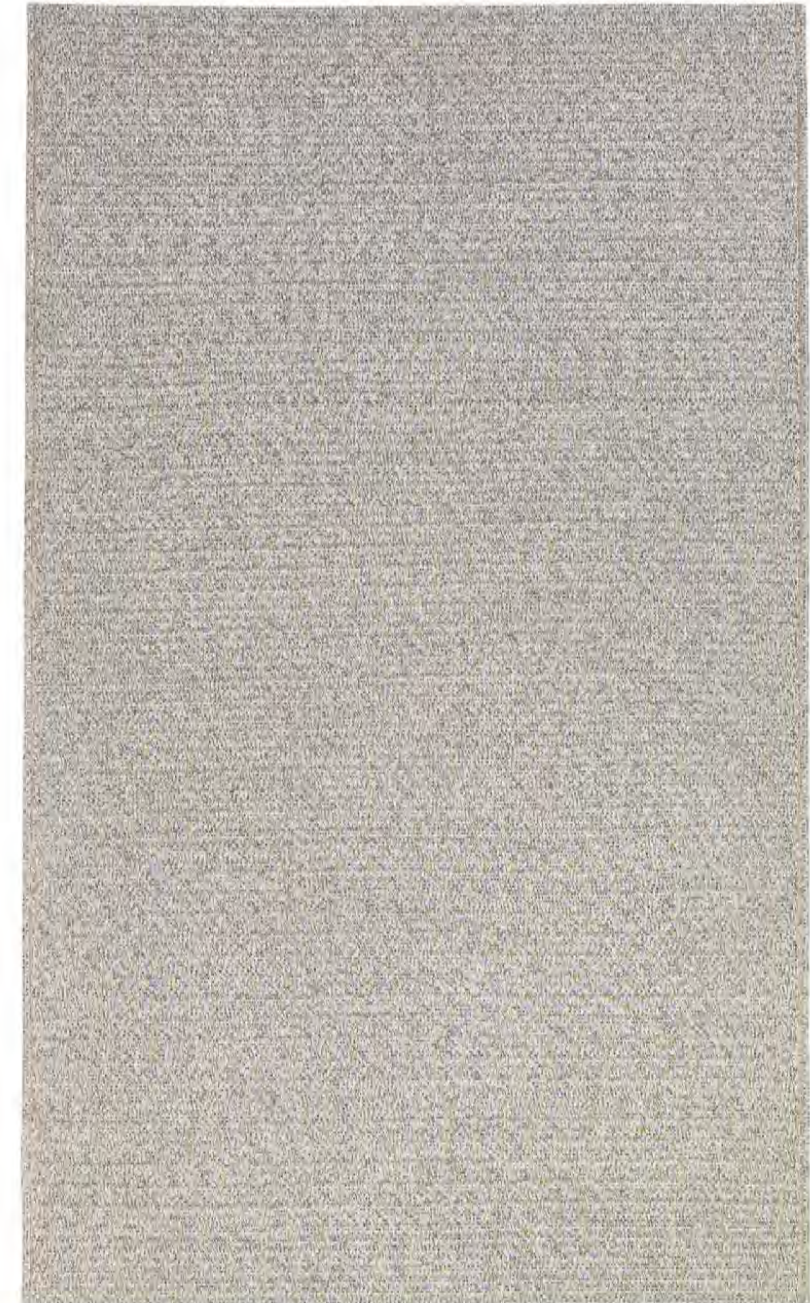
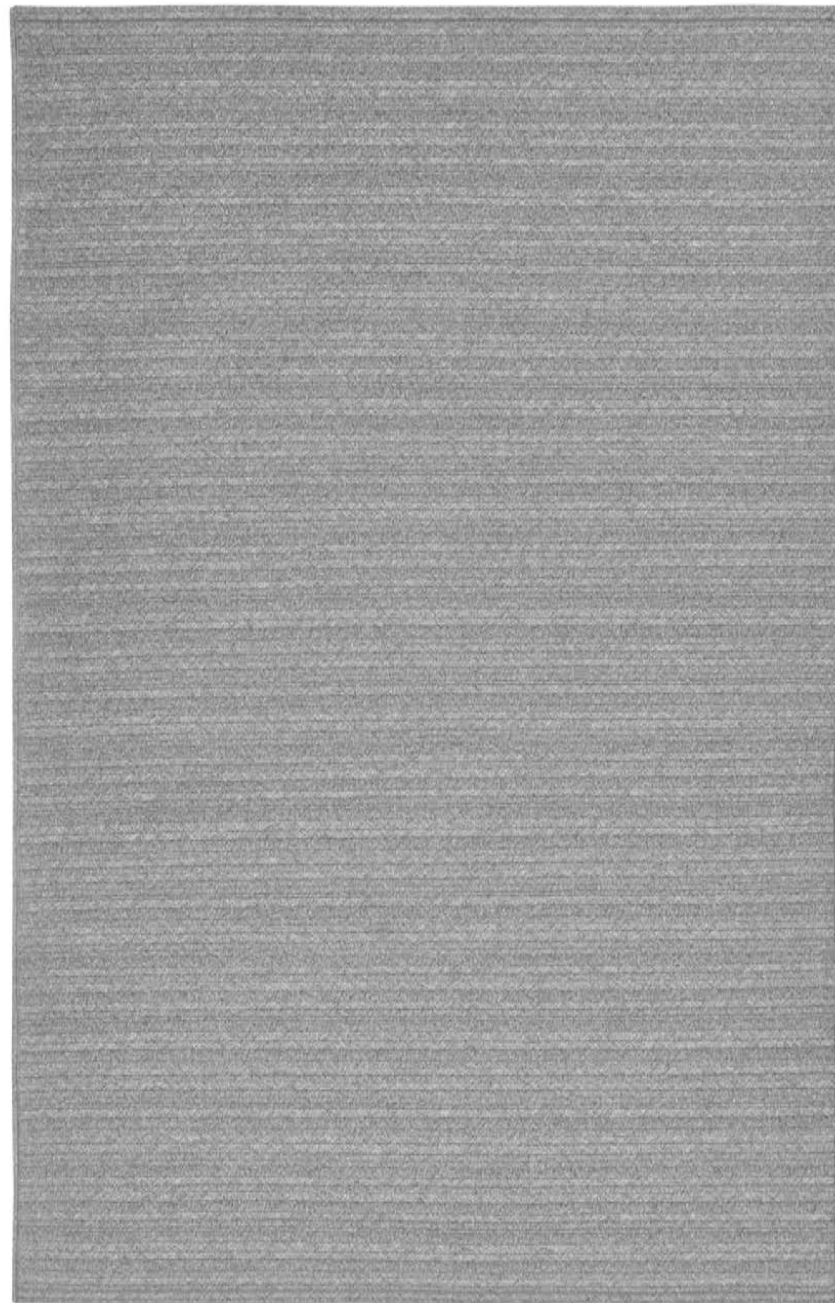

Opposite, nella pagina accanto
Twist, carpet, tappeto - TW200

This page, in questa pagina
Kaleidos, carpet, tappeto - TKA200

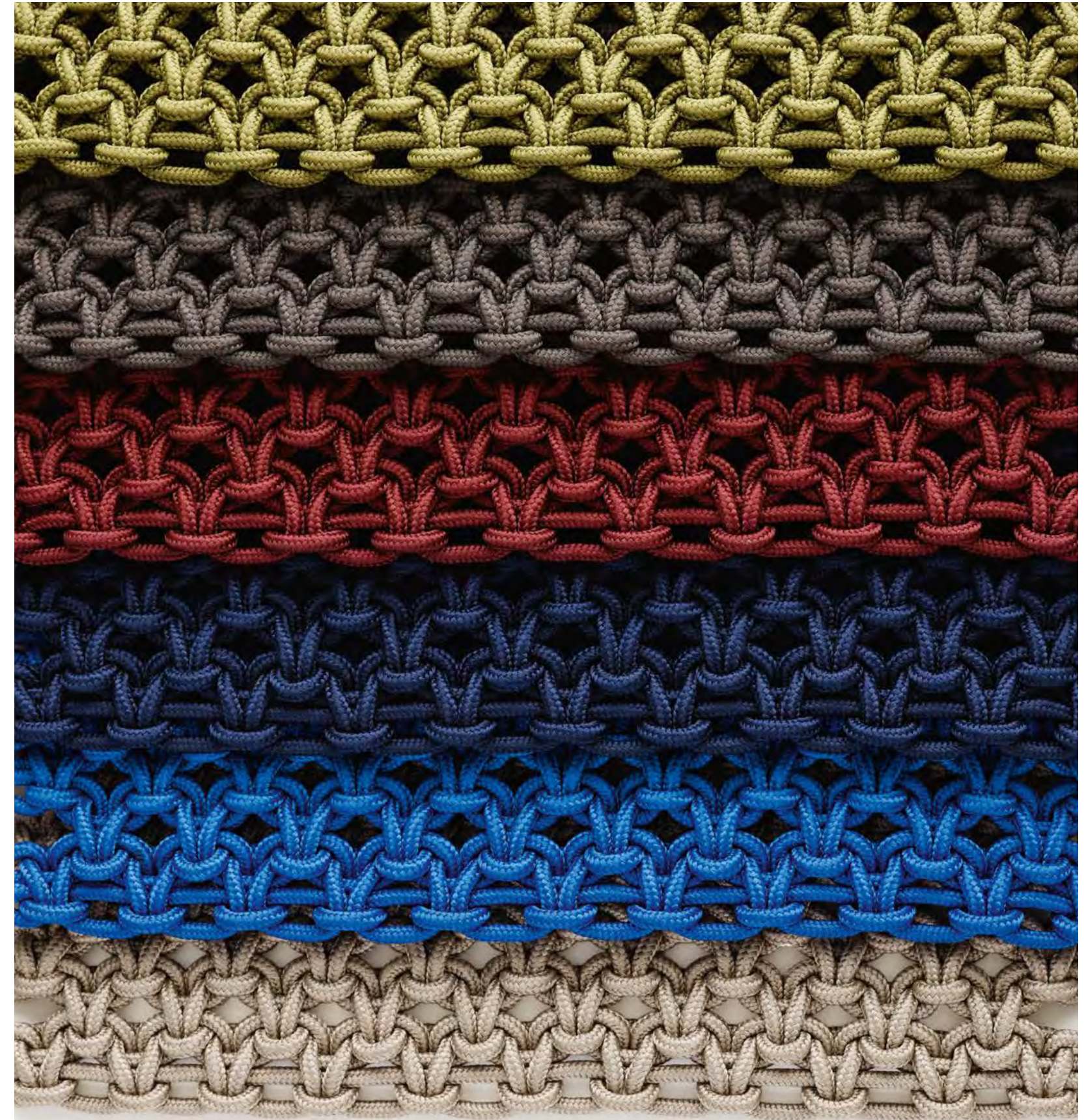
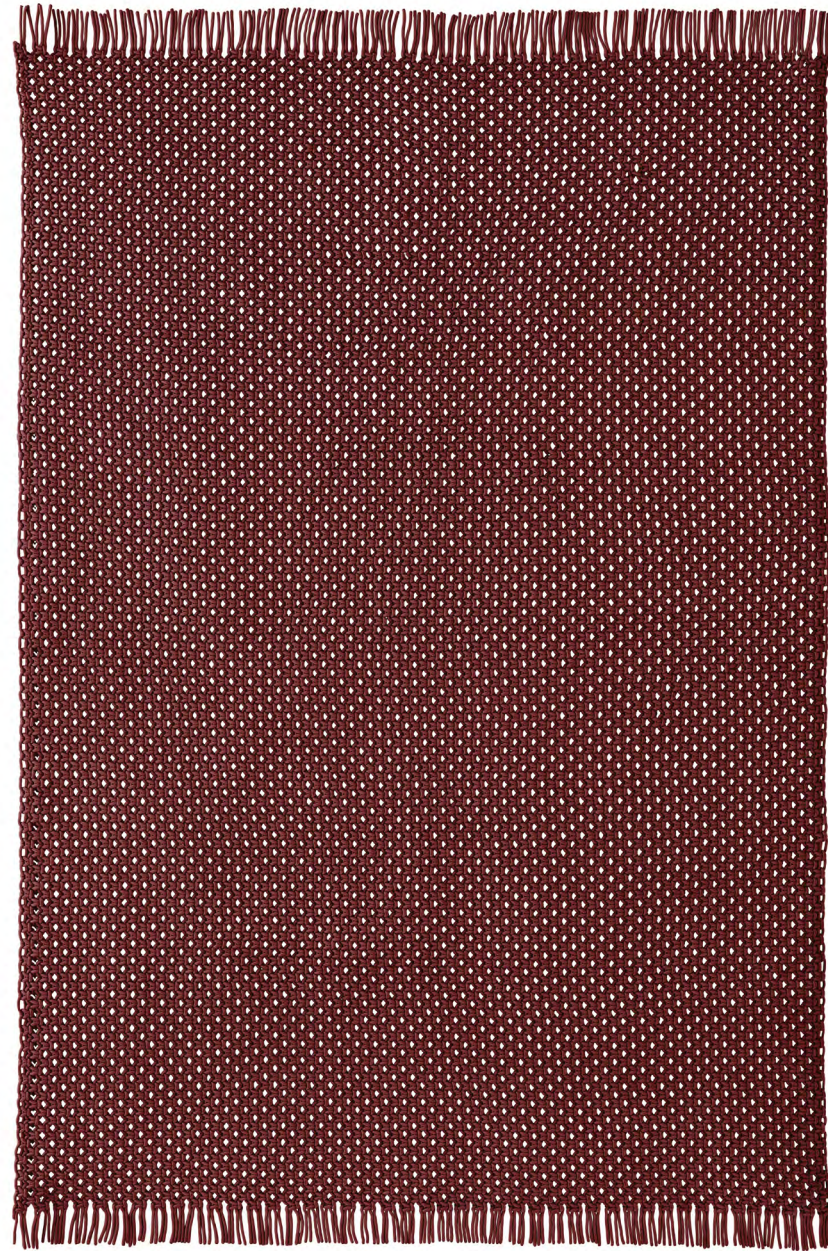

Karam,

come in various sizes and have been designed in sets of three: one for the table and one free-standing. They are in woven polypropylene and produced in 4 colour combinations: acid green/pistachio, overseas blue/blue royal, violet/red, stone/anthracite.

pensate in varie dimensioni come tris da tavolo e tris da terra, sono realizzate in cordoncino di polipropilene in quattro varianti che abbinano ciascuna due tonalità: verde acido/pistacchio, blu oltremare/blu royal, viola/rosso, sasso/antracite.





Opposite, nella pagina accanto:
Karam, floor baskets, ceste da terra - KA02
Karam, table bowls, ciotole da tavolo - KA01

Sofas, Divani



Bay

Nipa Doshi and Jonathan Levien
p 119, 120, 121, 127 - p 255



Bay

Nipa Doshi and Jonathan Levien
p 124, 125 - p 255



Canasta

Patricia Urquiola
p 145 - p 258



Fat-Sofa Outdoor

Patricia Urquiola
p 140 -141 - p 278



Fat-Sofa Outdoor

Patricia Urquiola
p 137 - p 278



Gio

Antonio Citterio
p 85 - p 284



Canasta

Patricia Urquiola
p 143, 144 - p 258



Canasta

Patricia Urquiola
p 148 - p 258



Canasta '13

Patricia Urquiola
p 152, 153, 154 - p 260



Ray Outdoor Fabric

Antonio Citterio
p 76 - 77 - p 306



Ray Outdoor Fabric

Antonio Citterio
p 306



Ray Outdoor Natural

Antonio Citterio
p 309



Canasta '13

Patricia Urquiola
p 155 - p 260



Canasta '13

Patricia Urquiola
p 156, 157 - p 260



Charles Outdoor

Antonio Citterio
p 97 - p 266



Ray Outdoor Natural

Antonio Citterio
p 67, 70, 71 - p 309



Ribes

Antonio Citterio
p 314



Ribes

Antonio Citterio
p 314



Erica

Antonio Citterio
p 60, 61 - p 272



Erica '19

Antonio Citterio
p 52, 53, 55 - p 274



Erica '19

Antonio Citterio
p 47, 48, 49 - p 274



Springtime

Jean-marie Massaud
p 217 - p 321



Springtime

Jean-marie Massaud
p 216 - p 321

Modular Sofas, Divani Componibili

Chaise Longue



Butterfly

Patricia Urquiola
p 134, 135 - p 256

Charles Outdoor

Antonio Citterio
p 92, 94, 95 - p 266

Gio

Antonio Citterio
p 84, 86, 87 - p 284

Charles Outdoor

Antonio Citterio
p 266

Charles Outdoor

Antonio Citterio
p 100 - p 266

Gio

Antonio Citterio
p 81, 82, 83 - p 284



Ravel

Patricia Urquiola
p 186, 187 - p 312

Ray Outdoor Fabric

Antonio Citterio
p 306

Ray Outdoor Fabric

Antonio Citterio
p 74, 75 - p 306

Mirto Outdoor

Antonio Citterio
p 31 - p 296

Mirto Outdoor

Antonio Citterio
p 30 - p 296

Ravel

Patricia Urquiola
p 312



Ray Outdoor Natural

Antonio Citterio
p 309

Ray Outdoor Natural

Antonio Citterio
p 309

Ribes

Antonio Citterio
p 5, 6, 7, 8, 9 - p 314

Ray Outdoor Fabric

Antonio Citterio
p 306

Ray Outdoor Fabric

Antonio Citterio
p 306

Ray Outdoor Natural

Antonio Citterio
p 68, 69 - p 309



Ribes

Antonio Citterio
p 20, 21, 22, 23 - p 314

Ray Outdoor Natural

Antonio Citterio
p 70, 71 - p 309

Ray Outdoor Fabric

Antonio Citterio
p 79 - p 306

Ribes

Antonio Citterio
p 5, 6, 7, 8, - p 314

Chaise Longue



Springtime

Jean-Marie Massaud
p 213, 214, 215 - p 322

Springtime

Jean-Marie Massaud
p 213, 214, 215 - p 322

Armchairs, Poltrone



Bay

Nipa Doshi and Jonathan Levien
p 119, 120, 121, 122 - p 255



Bay

Nipa Doshi and Jonathan Levien
p 123, 124, 125 - p 255



Canasta

Patricia Urquiola
p 146 - p 258



Canasta'13

Patricia Urquiola
p 151, 156, 157 - p 260



Charles Outdoor

Antonio Citterio
p 94, 95, 98, 99 - p 266



Crinoline

Patricia Urquiola
p 167, 168, 169, 170 - p 270



Erica

Antonio Citterio
p 62, 63 - p 272



Erica '19

Antonio Citterio
p 47, 48, 49, 50, 52, 53, 54, 55 - p 274



Fat-Sofa Outdoor

Patricia Urquiola
p 138, 139, 140, 141 - p 278



Gio

Antonio Citterio
p 86, 87 - p 284



Husk Outdoor

Patricia Urquiola
p 177, 178, 179 - p 288



Mirto Outdoor

Antonio Citterio
p 13, 15, 20, 21, 23, 32, 33, 34, 35, 38, 39, 40, 41 - p 296

Armchairs, Poltrone



Ray Outdoor Fabric

Antonio Citterio
p 76, 77 - p 306



Ray Outdoor Fabric

Antonio Citterio
p 73, 74, 75 - p 306



Ray Outdoor Natural

Antonio Citterio
p 68, 69 - p 309



Ray Outdoor Natural

Antonio Citterio
p 70, 71 - p 309

Ottomans, Pouf



Bay

Nipa Doshi and Jonathan Levien
p 123, 124, 125 - p 255



Fat-Sofa Outdoor

Patricia Urquiola
p 74, 75, 127, 138, 139, 167, 193 - p 278



Frank Outdoor

Antonio Citterio
p 5, 6, 7, 13, 14, 15, 20, 21, 23, 40, 41, 44, 52, 53, 113 - p 280



Husk Outdoor

Patricia Urquiola
p 288



Ravel

Patricia Urquiola
p 185 - p 312



Ribes

Antonio Citterio
p 314



Tabour Outdoor

Nipa Doshi and Jonathan Levien
p 119, 120, 121, 127, 128 - p 323

Tables, Tavoli**Canasta**

Patricia Urquiola
p 159, 161 - p 262

**Canasta'13**

Patricia Urquiola
p 162, 163 - p 264

**Crinoline**

Patricia Urquiola
p 173 - p 270

**Fiore**

Naoto Fukasawa
p 193, 194, 195, 197 - p 281

**Gelso**

Antonio Citterio
p 111 - p 282

**Ginestra**

Antonio Citterio
p 103, 105 - p 283

**Ginestra**

Antonio Citterio
p 106, 107, 109 - p 283

**Gio**

Antonio Citterio
p 88, 89, 91 - p 284

**Link Outdoor**

Jakob Wagner
p 205, 206, 207 - p 294

**Mirto Outdoor**

Antonio Citterio
p 33, 34, 35, 65 - p 296

**Mirto Outdoor**

Antonio Citterio
p 13, 15, 40, 41 - p 296

**Tobi-Ishi Outdoor**

Edward Barber and Jay Osgerby
p 115 - p 325

Chairs, Sedie**Canasta**

Patricia Urquiola
p 159 - p 258

**Canasta'13**

Patricia Urquiola
p 162, 163 - p 260

**Crinoline**

Patricia Urquiola
p 173, 174, 174, 175 - p 270

**Erica**

Antonio Citterio
p 64, 65 - p 272

**Erica '19**

Antonio Citterio
p 13, 15, 56, 57, 209 - p 274

**Ginestra**

Antonio Citterio
p 103, 106, 107, 108, 109 - p 283

**Gio**

Antonio Citterio
p 88, 89, 91 - p 284

**Husk Outdoor**

Patricia Urquiola
p 180 - p 288

**Mirto Outdoor**

Antonio Citterio
p 32, 34, 35 - p 296

**Papilio Shell Outdoor**

Naoto Fukasawa
p 111, 197 - p 305

Complements, Complementi**Gio**

Antonio Citterio
p 86, 87, 88, 89 - p 284

**Kaleidos**

B&B Italia CR&S
p 231 - p 291

**Karam**

B&B Italia CR&S
p 235, 236 - p 292

Small Tables, Tavolini**Awa Outdoor**

Naoto Fukasawa
p 203 - p 254

**Butterfly**

Patricia Urquiola
p 132, 133, 134, 135, 140, 141 - p 256

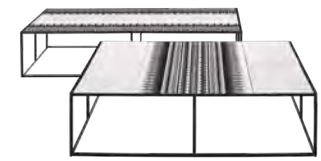
**Canasta**

Patricia Urquiola
p 5, 6, 7, 8, 9, 113, 143, 160 - p 262

**Kyra**

B&B Italia CR&S
p 232, 232 - p 293

**Mirto Outdoor**

Antonio Citterio
p 34, 35, 60, 61 - p 296

**Overscale Flames Outdoor**

Jean-Marie Massaud
p 213, 221, 222 - p 304

**Canasta**

Patricia Urquiola
p 258

**Canasta'13**

Patricia Urquiola
p 143, 165 - p 264

**Canasta'13**

Patricia Urquiola
p 151, 156, 157 - p 260

**Springtime**

Jean-Marie Massaud
p 94, 95, 217, 218, 219 - p 321

**Titikaka**

Naoto Fukasawa
p 199, 200 - p 324

**Twist**

B&B Italia CR&S
p 230 - p 326

**Cosmos Outdoor**

Jeffrey Bennett
p 209, 210, 211 - p 268

**Fat-Fat Outdoor**

Patricia Urquiola
p 23, 47, 48, 49, 55, 189 - p 276

**Fiore**

Naoto Fukasawa
p 59, 194, 195 - p 281

**White Collection**

Marcel Wanders
p 37, 159, 225, 226 - p 327

**Gio**

Antonio Citterio
p 68, 69, 73, 76, 77, 86, 87 - p 284

**Husk Outdoor**

Patricia Urquiola
p 177, 182 - p 288

**Mirto Outdoor**

Antonio Citterio
p 37, 60, 61 - p 296



Mirto Outdoor

Antonio Citterio
p 44, 52, 53 - p 296

Mirto Outdoor

Antonio Citterio
p 28, 29, 44 - p 296



Ravel

Patricia Urquiola
p 185, 186, 187 - p 312



Springtime

Jean-Marie Massaud
p 213, 215, 217 - p 321



Tobi-Ishi Outdoor

Edward Barber and Jay Osgerby
p 116, 124, 125 - p 325

Awa Outdoor, Naoto Fukasawa - 2009

TA1

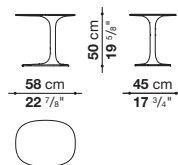

Top and base-frame	Cristalplant Outdoor® (natural mineral filler of phosphate of aluminium with polyester acrylate resin)	Piano e basamento	Cristalplant Outdoor® (carica minerale naturale di idrato d'alluminio con resina poliestere acrilata)
Ferrules	thermoplastic material	Puntali	materiale termoplastico

Top and base-frame
Piano e basamento

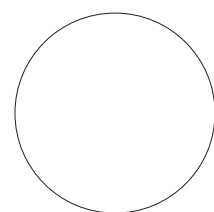

0101G
white Cristalplant Outdoor®
Cristalplant Outdoor® bianco

Bay, Nipa Doshi and Jonathan Levien - 2018

BY176

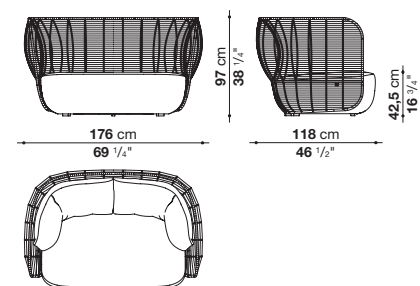

BY236

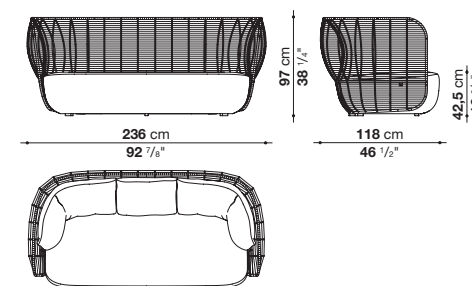

BY176CL

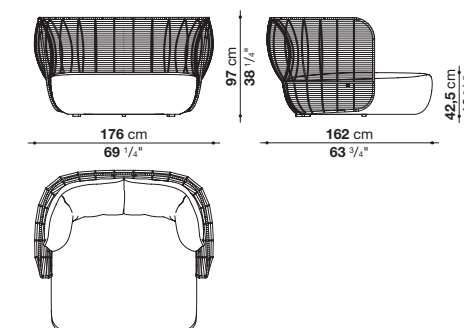

BY118B

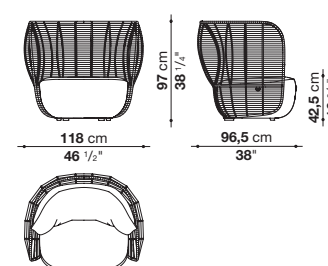

BY123A

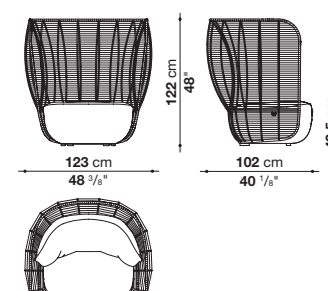

BY94

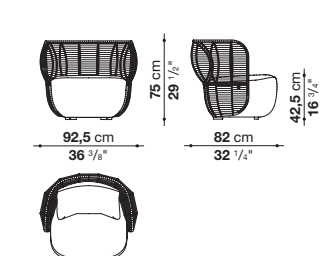

BY74PQ

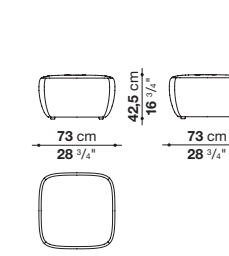

Internal frame	tubular steel and steel profiles	Telaio interno	tubolari e profilati d'acciaio
Back frame	aluminium	Telaio schienale	alluminio
Upholstery	Bayfit® (Bayer®) flexible cold shaped polyurethane foam, water repellent polyester fibre cover (with heat-sealed ribbon)	Imbottitura	schiuma di poliuretano flessibile a freddo Bayfit® (Bayer®), fodera in fibra di poliestere con trattamento idrorepellente (con cuciture termosaldate)
Back cushion	Solotex fibre and visco-elastic polyurethane combination, cover in water repellent polyester fibre	Cuscino schienale	combinazione fibra Solotex e poliuretano viscoelastico, fodera in fibra di poliestere con trattamento idrorepellente
Interlacing	polypropylene fibre braid	Intreccio	treccia in fibra di polipropilene
Feet and ferrules	thermoplastic material	Piedini e puntali	materiale termoplastico
Waterproof cover cloth	PES fabric coated on one side in PU	Telo di copertura impermeabile	tessuto PES monospalmato su un lato PU
Cover	fabric in limited categories	Rivestimento	tessuto in categorie limitate

Frame and interlacing matching
Abbinamento struttura e intreccio

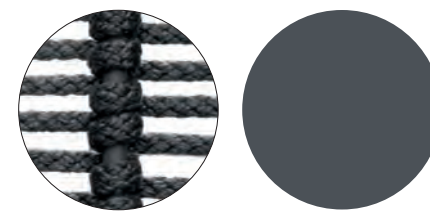

* 0158A
anthracite painted / anthracite polypropylene
verniciato antracite / polipropilene antracite

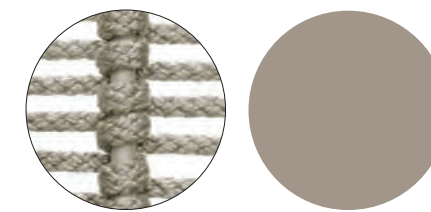

* 0833T
tortora painted / tortora polypropylene
verniciato tortora / polipropilene tortora

* Image not in scale / Immagine non in scala

Butterfly, Patricia Urquiola - 2015

BT112S

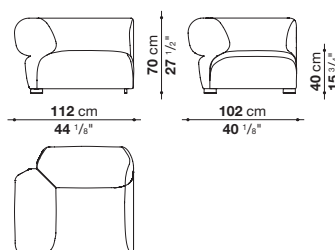

BT90C

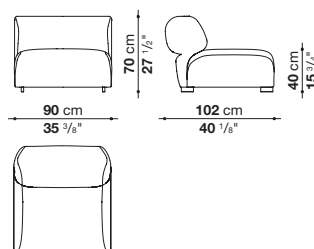

BT7

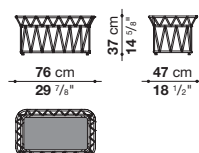

BT7Q

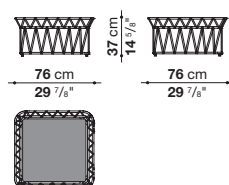

BT112D

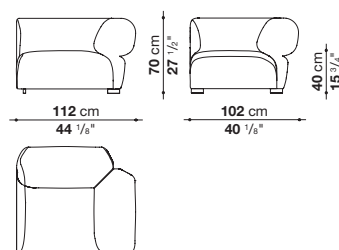

BT90P

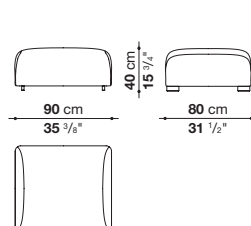

BT15

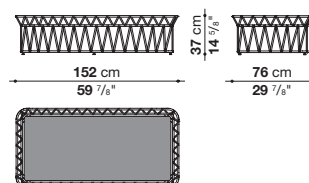

BT9R

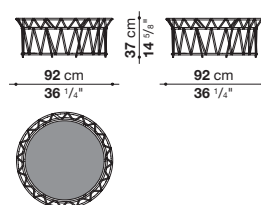

Internal frame	tubular steel and steel profiles
Internal frame upholstery	Bayfit® (Bayer®) flexible cold shaped polyurethane foam, water repellent polyester fibre cover (with heat-sealed ribbon)
Frame (BT7-BT7Q-BT9R-BT15)	aluminium with polyester powder painting
Interlacing (BT7-BT7Q-BT9R-BT15)	polyethylene fibre
Top (BT7-BT7Q-BT9R-BT15)	marble (natural finish) or wooden slats
Feet, ferrules and fixing elements	thermoplastic material
Waterproof cover cloth	PES fabric coated on one side in PU
Cover	fabric in limited categories

Telaio interno	tubolari e profilati d'acciaio
Imbottitura telaio interno	schiuma di poliuretano flessibile a freddo Bayfit® (Bayer®), fodera in fibra di poliestere con trattamento idrorepellente (con cuciture termosaldate)
Struttura (BT7-BT7Q-BT9R-BT15)	alluminio con verniciatura a polvere poliestere
Intreccio (BT7-BT7Q-BT9R-BT15)	fibra di polietilene
Piano (BT7-BT7Q-BT9R-BT15)	marmo (finitura naturale) o doghe di legno
Piedini, puntali ed elementi di fissaggio	materiale termoplastico
Telo di copertura impermeabile	tessuto PES monospalmato su un lato PU
Rivestimento	tessuto in categorie limitate

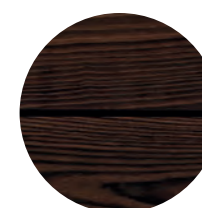
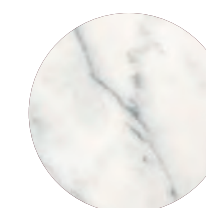
Interlacing
Intreccio* 0612T
tortora polyethylene
polietilene tortoraTop
Piano0430L
thermo-treated ash
frassino termotrattato0900M
natural Carrara white
"venatino statuarietto" marble
marmo bianco Carrara
"venatino statuarietto" naturale

Canasta, Patricia Urquiola - 2007

CN160P1

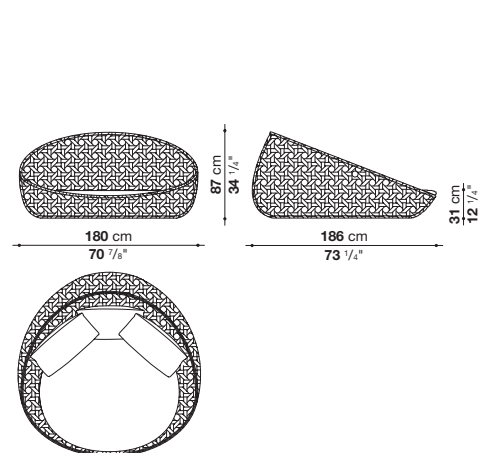

CN160P1, CN160P1W, CN160P1C

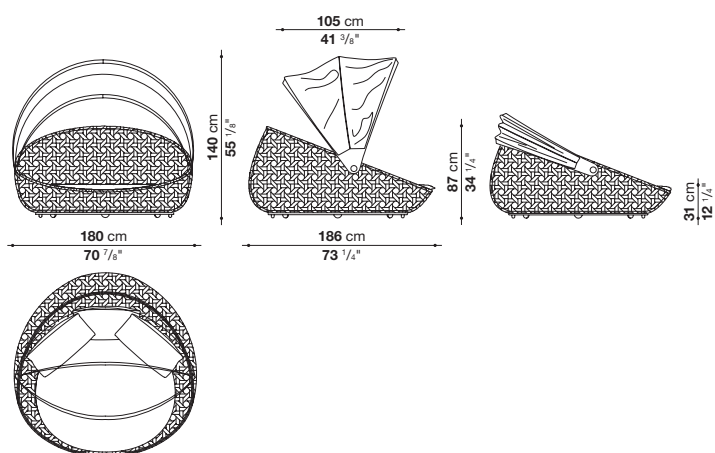

CN190B

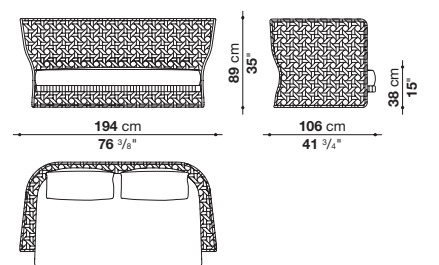

CN226B

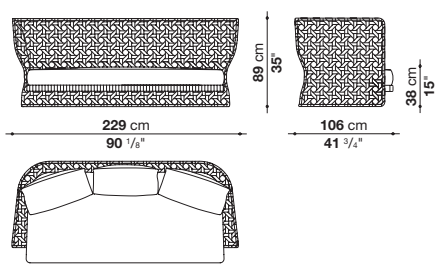

CN98PB

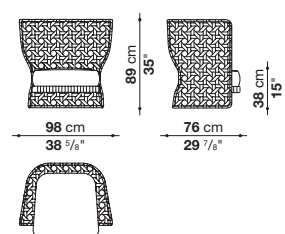

CN98PA

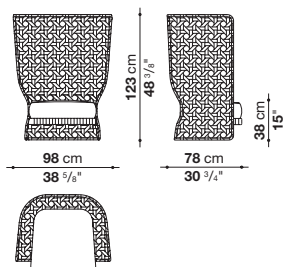

SCN63

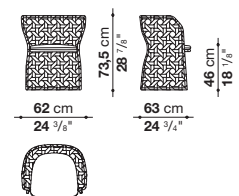

PCN60

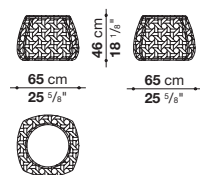

PCN80

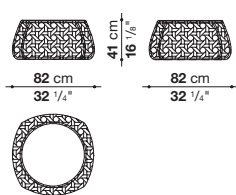

PCN110

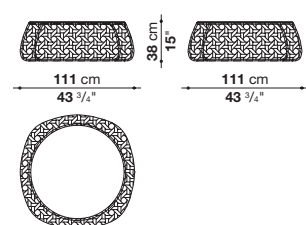

Frame	aluminium or steel with polyester powder painting
Interlacing	polyethylene fibre
Seat cushion (CN190B-CN226B-CN98PB-CN98PA)	shaped polyurethane, cover in water repellent polyester fibre (with heat-sealed ribbon)
Seat cushion (CN160P1-SCN63)	shaped polyurethane, cover in water repellent polyester fibre (with heat-sealed ribbon)
Back cushion	polyester fibre, cover in water repellent polyester fibre
Canopy frame (CN160P1C)	glass fibre
Canopy mechanism (CN160P1C)	electro polished steel, anodized aluminium
Canopy cover (CN160P1C)	Bolero fabric and Batik fabric
Wheels (CN160P1W)	plastic material, elastomeric polyurethane, electro polished stainless steel pin
Service element tray (PCN60-PCN80-PCN110)	steel sheet with polyester powder painting
Ferrules	thermoplastic material
Waterproof cover cloth	PES fabric coated on one side in PU
Cover	fabric in limited categories

Struttura	alluminio o acciaio con verniciatura a polvere poliesteri
Intreccio	fibra di polietilene
Cuscino sedile (CN190B-CN226B-CN98PB-CN98PA)	poliuretano sagomato, fodera in fibra di poliesteri con trattamento idrorepellente (con cuciture termosaldate)
Cuscino sedile (CN160P1-SCN63)	poliuretano sagomato, fodera in fibra di poliesteri con trattamento idrorepellente (con cuciture termosaldate)
Cuscino schienale	fibra di poliesteri, fodera in fibra di poliesteri con trattamento idrorepellente
Struttura capote (CN160P1C)	vetroresina
Meccanismo capote (CN160P1C)	acciaio elettrolucidato, alluminio anodizzato
Rivestimento capote (CN160P1C)	tessuto Bolero e tessuto Batik
Ruote (CN160P1W)	materiale plastico, poliuretano elastomero, perno in acciaio inox elettrolucidato
Vassoio elemento di servizio (PCN60-PCN80-PCN110)	lamiera d'acciaio con verniciatura a polvere poliesteri
Puntali	materiale termoplastico
Telo di copertura impermeabile	tessuto PES monospalmato su un lato PU
Rivestimento	tessuto in categorie limitate

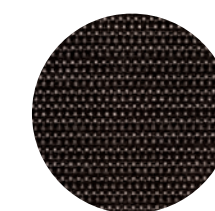
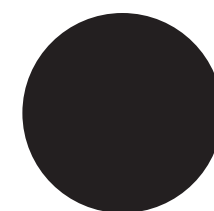
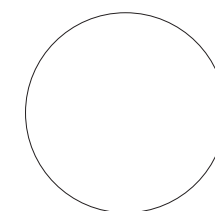
Interlacing
Intreccio* 0200W
white polyethylene
polietilene biancoCanopy cover (CN160P1)
Rivestimento capote (CN160P1)2376100
white Bolero fabric
tessuto Bolero bianco2593360
bronze Batik fabric
tessuto Batik bronzoTray (PCN60 - PCN80 - PCN110)
Vassoio (PCN60 - PCN80 - PCN110)09005
black painted
verniciato nero0179A
white painted
verniciato bianco

Canasta '13, Patricia Urquiola - 2013

CNC160P1

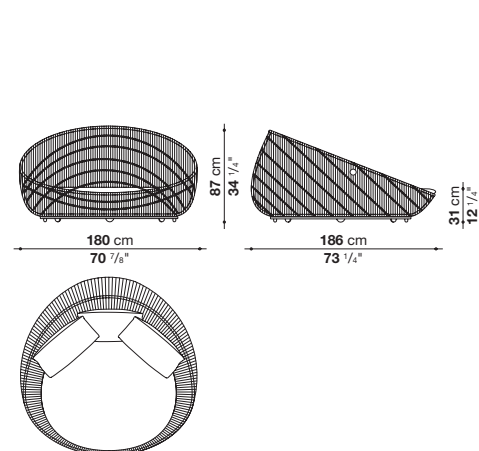

CNC160P1, CNC160P1C

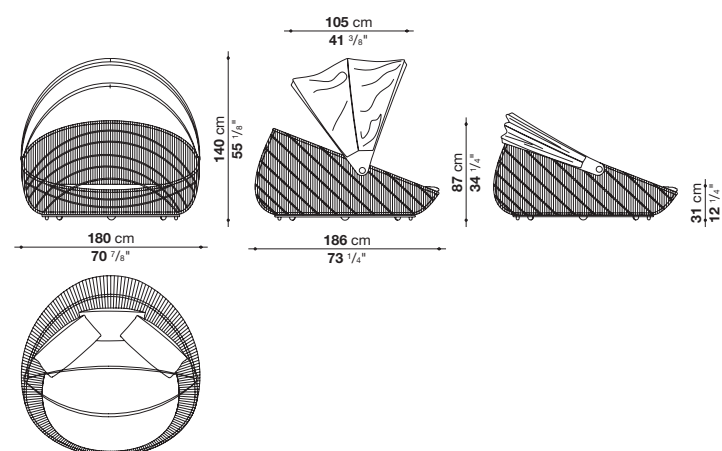

CNC190B

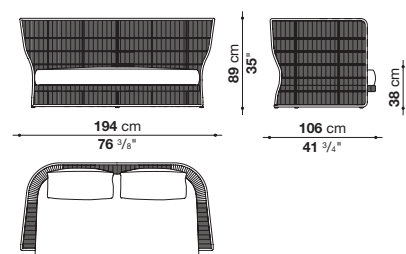

CNC226B

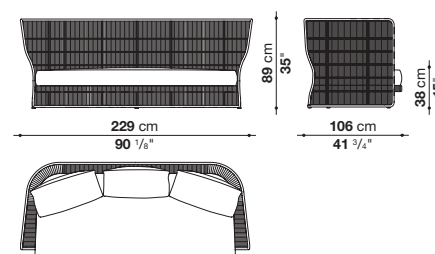

CNC98PB

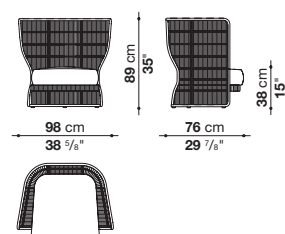

CNC98PA

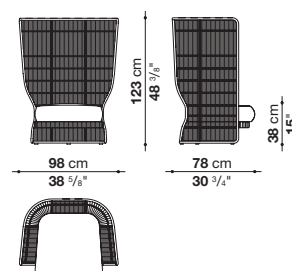

SCNC63

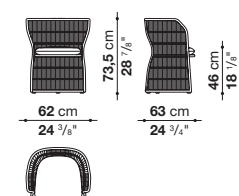

PCNC60

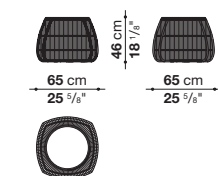

PCNC80

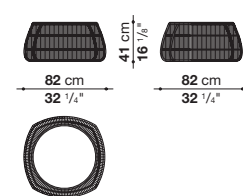

PCNC110

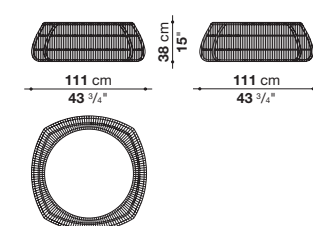

Frame	aluminium or steel with polyester powder painting
Interlacing	polyethylene fibre
Seat cushion (CNC190B-CNC226B-CNC98PB-CNC98PA)	shaped polyurethane, cover in water repellent polyester fibre (with heat-sealed ribbon)
Seat cushion (CNC160P1-SCNC63)	shaped polyurethane, cover in water repellent polyester fibre
Back cushion	polyester fibre, cover in water repellent polyester fibre
Canopy frame (CNC160P1C)	glass fibre
Canopy mechanism (CNC160P1C)	electro polished steel, anodized aluminium
Canopy cover (CNC160P1C)	Balivo fabric
Service element tray (PCNC60-PCNC80-PCNC110)	steel sheet with polyester powder painting
Wheels and ferrules	thermoplastic material
Waterproof cover cloth	PES fabric coated on one side in PU
Cover	fabric in limited categories

Struttura	alluminio o acciaio con verniciatura a polvere poliestere
Intreccio	fibra di polietilene
Cuscino sedile (CNC190B-CNC226B-CNC98PB-CNC98PA)	poliuretano sagomato, fodera in fibra di poliestere con trattamento idrorepellente (con cuciture termosaldate)
Cuscino sedile (CNC160P1-SCNC63)	poliuretano sagomato, fodera in fibra di poliestere con trattamento idrorepellente
Cuscino schienale	fibra di poliestere, fodera in fibra di poliestere con trattamento idrorepellente
Struttura capote (CNC160P1C)	vetroresina
Meccanismo capote (CNC160P1C)	acciaio elettrolucidato, alluminio anodizzato
Rivestimento capote (CNC160P1C)	tessuto Balivo
Vassoio elemento di servizio (PCNC60-PCNC80-PCNC110)	lamiera d'acciaio con verniciatura a polvere poliestere
Ruote e puntali	materiale termoplastico
Telo di copertura impermeabile	tessuto PES monospalmato su un lato PU
Rivestimento	tessuto in categorie limitate

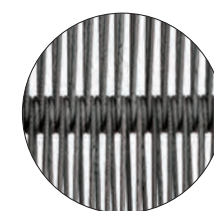
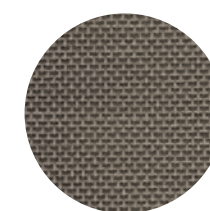
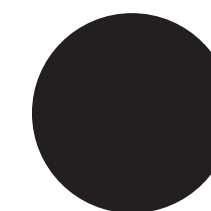
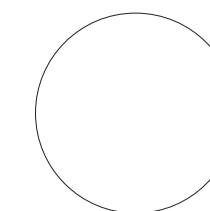
Interlacing
Intreccio* 0280P
tortora polyethylene
polietilene tortoraCanopy cover (CNC160P1)
Rivestimento capote (CNC160P1)2387280
tortora Balivo fabric
tessuto Balivo tortoraTray (PCNC60 - PCNC80 - PCNC110)
Vassoio (PCNC60 - PCNC80 - PCNC110)09005
black painted
verniciato nero0179A
white painted
verniciato bianco

Canasta tables, Patricia Urquiola - 2007

Canasta

TCN224

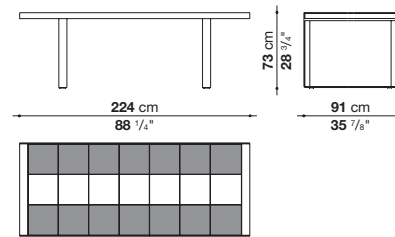

TCN15

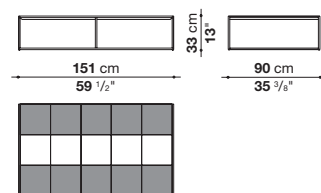

TCN3

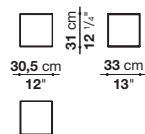

TCN283N

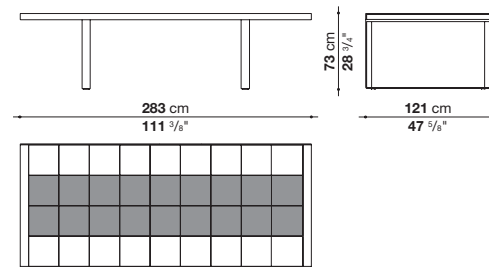

TCN12

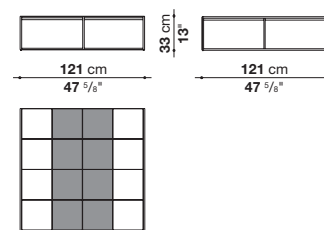

Frame	tiles in porcelain stoneware
Top	tiles in porcelain stoneware
Ferrules	thermoplastic material
Waterproof cover cloth	PES fabric coated on one side in PU

Struttura	alluminio o acciaio con verniciatura a polvere poliestere
Piano	piastrelle in gres porcellanato
Puntali	materiale termoplastico
Telo di copertura impermeabile	tessuto PES monospalmato su un lato PU

Top
Piano

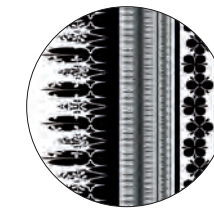

* 1510A
porcelain stoneware with
black / white decoration
gres porcellanato con
decoro nero / bianco

Frame (TCN224 - TCN283N)
Struttura (TCN224 - TCN283N)

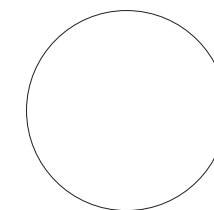

0179A
white painted
verniciato bianco

Frame (TCN3 - TCN12 - TCN15)
Struttura elementi di servizio (TCN3 - TCN12 - TCN15)

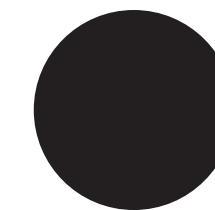

09005
black painted
verniciato nero

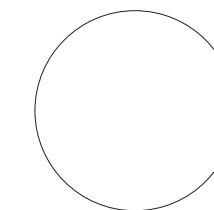

0179A
white painted
verniciato bianco

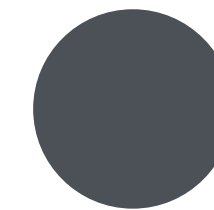

0236B
anthracite painted
verniciato antracite

* Image not in scale / Immagine non in scala

Canasta tables, Patricia Urquiola - 2007

Canasta '13

TCNC224

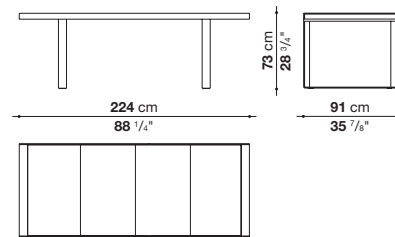

TCNC3

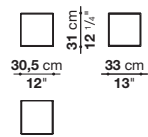

TCNC283

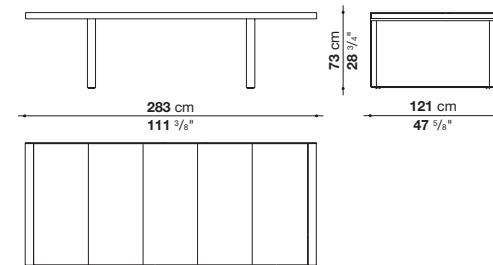

TCNC4

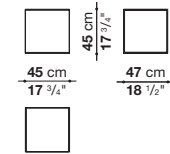

Top	tiles in porcelain stoneware
Frame	aluminium or steel with polyester powder painting
Table top support	aluminium sheet with polyester powder painting
Ferrules	thermoplastic material
Waterproof cover cloth	PES fabric coated on one side in PU

Piano	piastrelle in gres porcellanato
Struttura	alluminio o acciaio con verniciatura a polvere poliesteri
Supporto piano tavolo	lamiera d'alluminio con verniciatura a polvere poliesteri
Puntali	materiale termoplastico
Telo di copertura impermeabile	tessuto PES monospalmato su un lato PU

Top
Piano

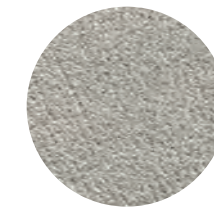

1560E
cement porcelain stoneware
gres porcellanato cemento

Frame
Struttura

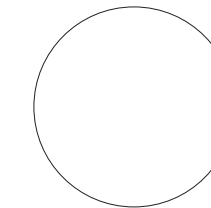

0179A
white painted
verniciato bianco

Frame (TCNC3 - TCNC4)
Struttura (TCNC3 - TCNC4)

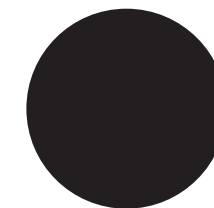

09005
black painted
verniciato nero

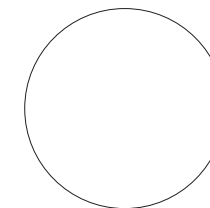

0179A
white painted
verniciato bianco

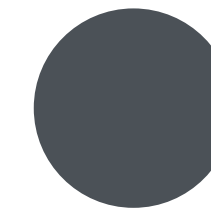

0236B
anthracite painted
verniciato antracite

Charles Outdoor, Antonio Citterio - 2010

CHO84

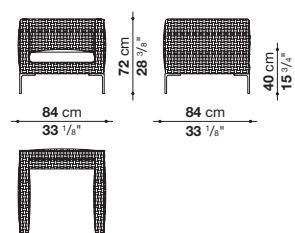

* CHO160D

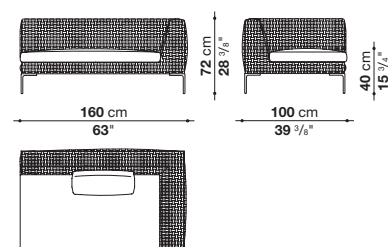

* CHO160LD

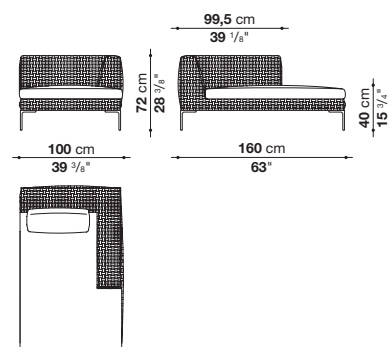

CHO202L

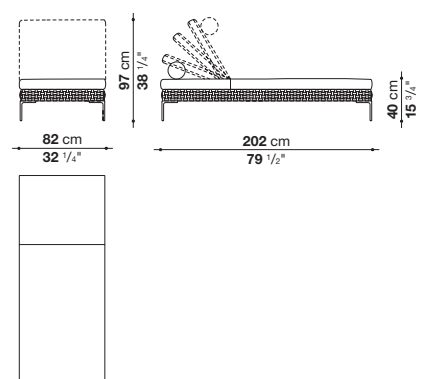

* Elements available in right and left version. / Elementi disponibili nella versione destra e sinistra.

CHO234

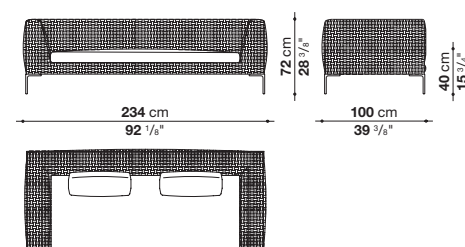

* CHO234D

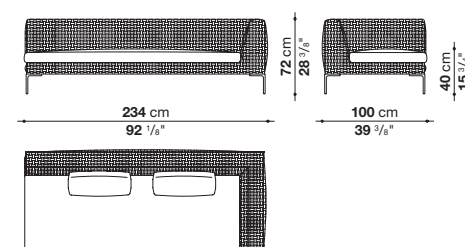

* CHO234LD

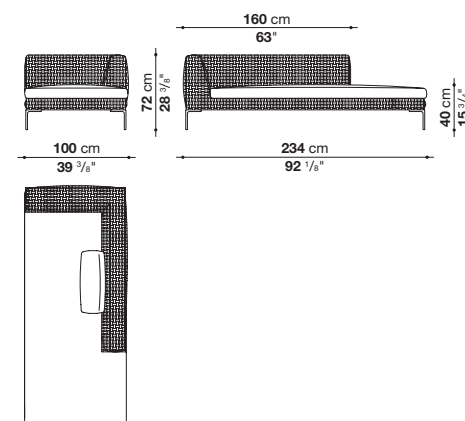

CHO202LA

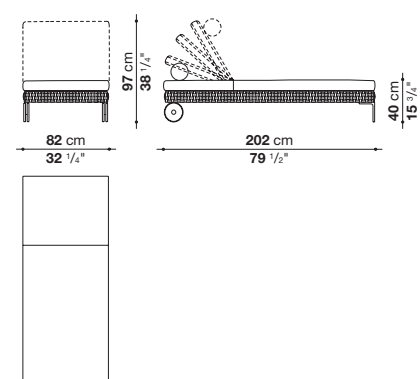

Internal frame	tubular aluminium and aluminium profiles
Interlacing	polypropylene fibre
Seat cushion	shaped polyurethane, cover in water repellent polyester fibre
Back cushion	polyester fibre, cover in water repellent polyester fibre
Headrest cushion (CHO202L-CHO202LA)	shaped polyurethane, cover in water repellent polyester fibre
Seat top (CHO202L-CHO202LA)	HPL stratified laminate panel
Mechanism (CHO202L-CHO202LA)	aluminium extrusion
Wheels (CHO202LA)	steel and thermoplastic material
Feet	die-cast aluminium with polyester powder painting
Ferrules	thermoplastic material
Waterproof cover cloth	PES fabric coated on one side in PU
Cover	fabric in limited categories

Telaio interno	tubolari e profilati d'alluminio
Intreccio	fibra di polipropilene
Cuscino sedile	poliuretano sagomato, fodera in fibra di poliestere con trattamento idrorepellente
Cuscino schienale	fibra di poliestere, fodera in fibra di poliestere con trattamento idrorepellente
Cuscino poggiatesta (CHO202L-CHO202LA)	poliuretano sagomato, fodera in fibra di poliestere con trattamento idrorepellente
Piano sedile (CHO202L-CHO202LA)	pannello in laminato stratificato HPL
Meccanismo (CHO202L-CHO202LA)	estruso d'alluminio
Ruote (CHO202LA)	acciaio e materiale termoplastico
Piedini	fusione d'alluminio con verniciatura a polvere poliestere
Puntali	materiale termoplastico
Telo di copertura impermeabile	tessuto PES monospalmato su un lato PU
Rivestimento	tessuto in categorie limitate

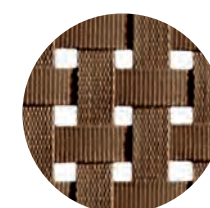
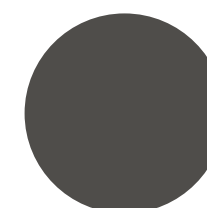
Interlacing
Intreccio* 0115P
brown polypropylene
polipropilene marroneFeet
Piedini0174B
bronzed nickel painted
verniciato nickel bronzato

* Image not in scale / Immagine non in scala

Cosmos Outdoor, Jeffrey Bernett - 2019

OTC90Q_2

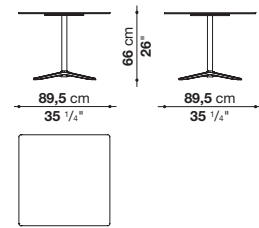

OTC90Q_1

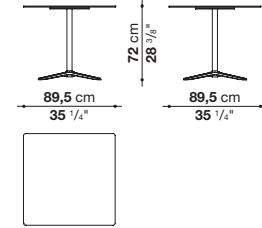

OTC90R_2

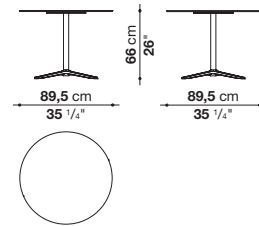

OTC90R_1

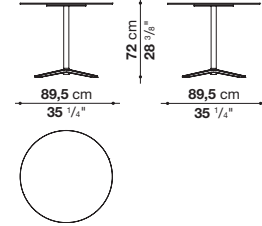

OTC80R

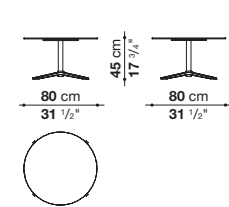

OTC50R

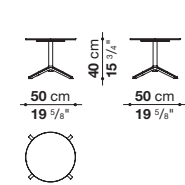

Frame	aluminium
Top	porcelain stoneware
Ferrules	thermoplastic material

Struttura	alluminio
Piano	gres porcellanato
Puntali	materiale plastico

Frame
Struttura

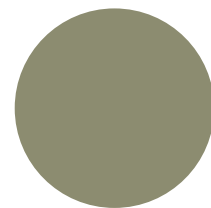

0427S
sage painted
verniciato salvia

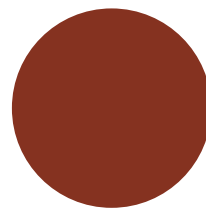

0750A
clay painted
verniciato argilla

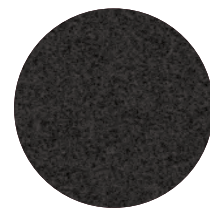

0236B
anthracite painted
verniciato antracite

Top
Piano

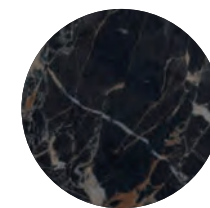

0355N
anthracite stone
porcelain stoneware
gres porcellanato
pietra antracite



0266B
white statuary
porcelain stoneware
gres porcellanato
statuario bianco

Crinoline, Patricia Urquiola - 2008

C1PF

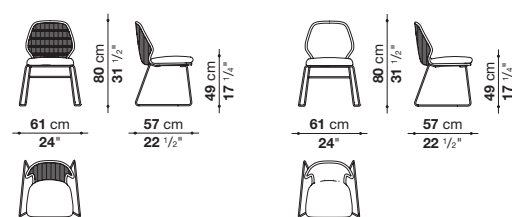

C6PF

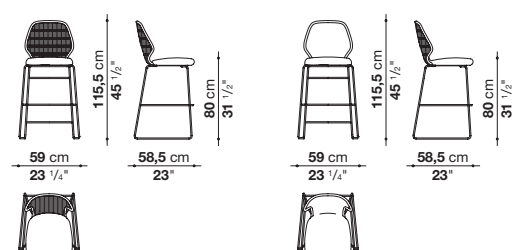

C2P

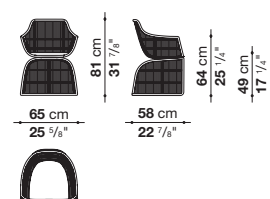

C5P

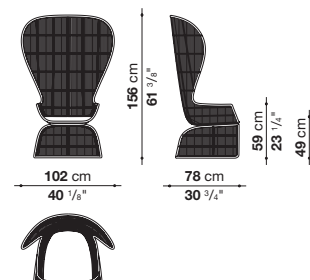

TC138

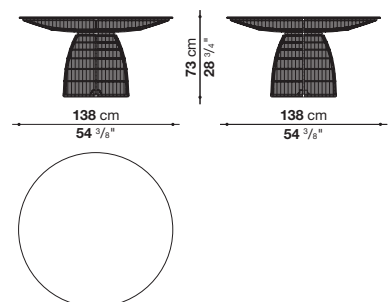

C2PF

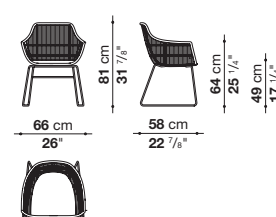

C7PF

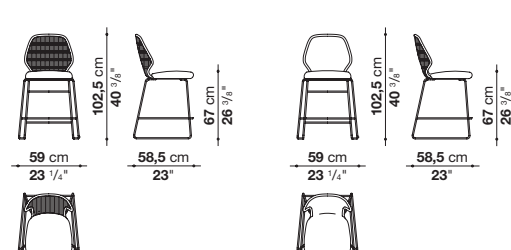

C3P

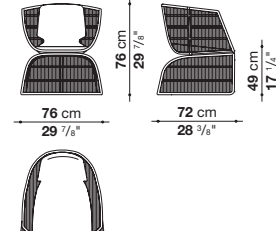

C5C

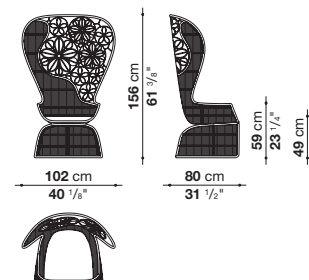

TC138F

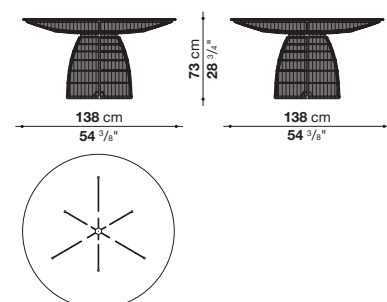

Base-frame	stainless steel or aluminium with polyester powder painting
Seat and back frame	aluminium with polyester powder painting
Seat cushion/Seat and back cushion	shaped polyurethane, cover in water repellent polyester fibre
Seat cushion (C5P-C5C)	shaped polyurethane, cover in water repellent polyester fibre (with heat-sealed ribbon)
Interlacing	polyethylene fibre or abaca
Top (TC138-TC138F)	glass or full color HPL stratified laminate
Base-frame (TC138-TC138F)	steel with polyester powder painting
Ferrules	thermoplastic material
Waterproof cover cloth	PES fabric coated on one side in PU
Cover	fabric in limited categories

Struttura base	alluminio con verniciatura a polvere poliestere o acciaio inossidabile
Struttura sedile e schienale	alluminio con verniciatura a polvere poliestere
Cuscino sedile/Cuscino sedile e schienale	poliuretano sagomato, fodera in fibra di poliestere con trattamento idrorepellente
Cuscino sedile (C5P-C5C)	poliuretano sagomato, fodera in fibra di poliestere con trattamento idrorepellente (con cuciture termosaldate)
Intreccio	fibra di polietilene o abaca
Piano (TC138-TC138F)	vetro o laminato stratificato HPL full color
Basamento (TC138-TC138F)	acciaio con verniciatura a polvere poliestere
Puntali	materiale termoplastico
Telo di copertura impermeabile	tessuto PES monospalmato su un lato PU
Rivestimento	tessuto in categorie limitate

Interlacing
Intreccio

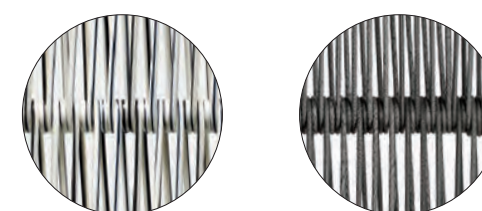

* 0111P
white / black polyethylene
polietilene bianco / nero

* 0280P
tortora polyethylene
polietilene tortora

Interlacing (C5C)
Intreccio (C5C)

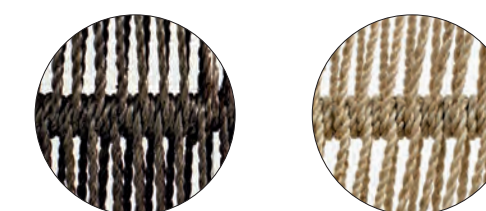

* 0360C
grey abaca
abaca grigio

* 0203C
natural abaca
abaca naturale

Top (TC138)
Piano (TC138)



0100H
white back-painted
etched glass
vetro acidato
retro-verniciato bianco

Top (TC138F)
Piano (TC138F)

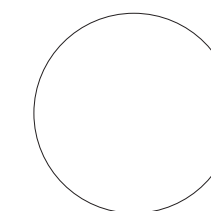

0255B
white full color HPL
stratified laminate
laminato stratificato HPL
full color bianco

* Image not in scale / Immagine non in scala

Erica, Antonio Citterio - 2017

E170

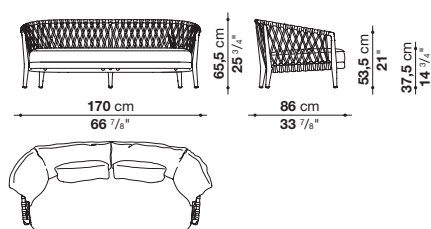

E216

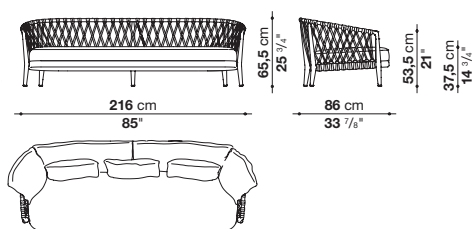

E90P

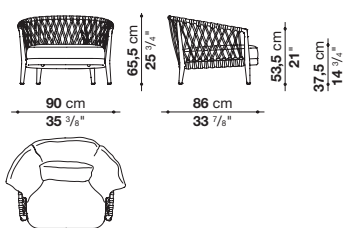

E80P

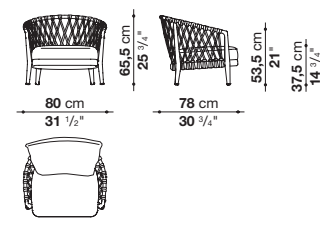

E61S

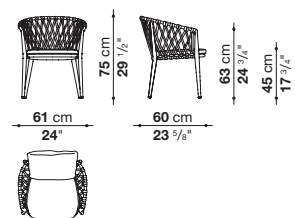

E61S_I

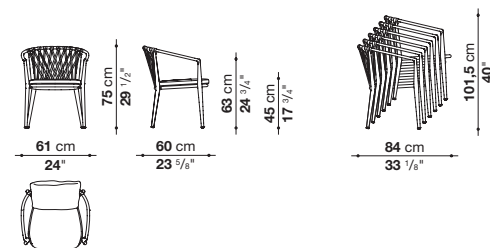

Frame	die-cast aluminium and extrusions with polyester powder painting
Back upholstery (E170-E216-E90P-E80P)	shaped polyurethane of different density, Solutex fibre and visco-elastic polyurethane combination, cover in water repellent polyester fibre
Back upholstery (E61S-E61S_I)	polyester fibre and polyurethane combination
Seat upholstery	shaped polyurethane, Solutex fibre and visco-elastic polyurethane combination, cover in water repellent polyester fibre
Interlacing	polypropylene fibre braid
Seat webbing	polypropylene fibre and synthetic rubber threads
Ferrules	thermoplastic material
Waterproof cover cloth	PES fabric coated on one side in PU
Cover	fabric in limited categories

Struttura	pressofusione ed estrusi d'alluminio con verniciatura a polvere poliesteri
Imbottitura schienale (E170-E216-E90P-E80P)	poliuretano sagomato a densità differenziata, combinazione fibra Solutex e poliuretano viscoelastico, fodera in fibra di poliestere con trattamento idrorepellente
Imbottitura schienale (E61S-E61S_I)	combinazione fibra di poliestere e poliuretano
Imbottitura sedile	poliuretano sagomato, combinazione fibra Solutex e poliuretano viscoelastico, fodera in fibra di poliestere con trattamento idrorepellente
Intreccio	treccia in fibra di polipropilene
Cinghiatura sedile	fibra di polipropilene e fili di gomma sintetica
Puntali	materiale termoplastico
Telo di copertura impermeabile	tessuto PES monospalmato su un lato PU
Rivestimento	tessuto in categorie limitate

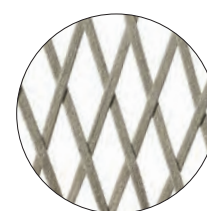
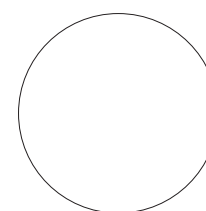
Frame and interlacing matching
Abbinamento struttura e intreccio

* 0711C
white painted / tortora polypropylene
verniciato bianco / polipropilene tortora

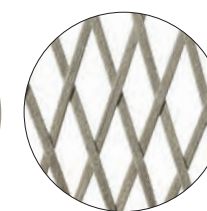
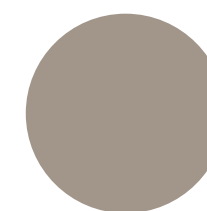

* 0828T
tortora painted / tortora polypropylene
verniciato tortora / polipropilene tortora

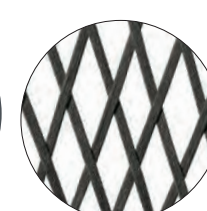
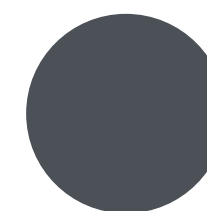

* 0625G
anthracite painted / anthracite polypropylene
verniciato antracite / polipropilene antracite

Erica '19, Antonio Citterio - 2019

9NE170

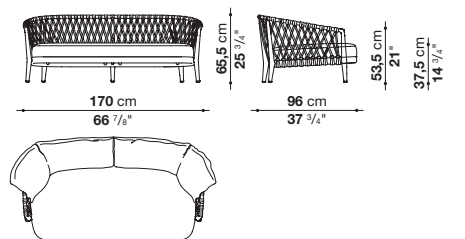

NE153

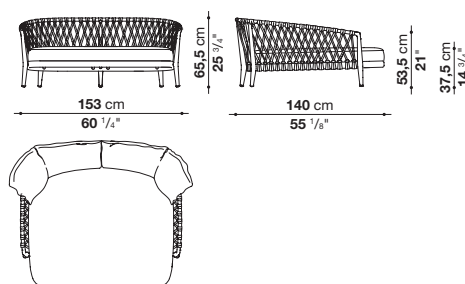

Frame	die-cast aluminium and extrusions with polyester powder painting
Back upholstery	ecogreen (polyethylene and polyester blend), cover in water repellent polyester fibre
Back upholstery (British Standard version)	shaped polyurethane of different density, Solutex fibre and visco-elastic polyurethane combination, cover in water repellent polyester fibre
Back upholstery (NE61S_I) (British Standard version)	polyester fibre and polyurethane combination
Seat upholstery	shaped polyurethane, ecogreen (polyethylene and polyester blend), cover in water repellent polyester fibre
Seat upholstery (British Standard version)	shaped polyurethane, Solutex fibre and visco-elastic polyurethane combination, cover in water repellent polyester fibre (with heat-sealed ribbon)
Seat webbing	polypropylene fibre and synthetic rubber threads
Interlacing	polypropylene fibre braid
Ferrules	thermoplastic material
Waterproof cover cloth	PES fabric coated on one side in PU
Cover	fabric in limited categories (with profile)
Cover (British Standard version)	fabric in limited categories (without profile)

9NE216

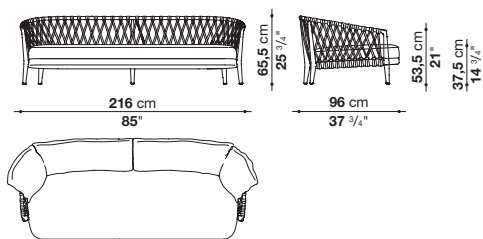

NE80P

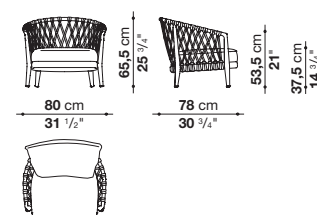

Struttura	pressofusione ed estrusi d'alluminio con verniciatura a polvere poliestere
Imbottitura schienale	ecogreen (misto polietilene e poliestere), fodera in fibra di poliestere con trattamento idrorepellente
Imbottitura schienale (versione British Standard)	poliuretano sagomato a densità differenziata, combinazione fibra Solutex e poliuretano viscoelastico, fodera in fibra di poliestere con trattamento idrorepellente
Imbottitura schienale (NE61S_I) (versione British Standard)	combinazione fibra di poliestere e poliuretano
Imbottitura sedile	poliuretano sagomato, ecogreen (misto polietilene e poliestere), fodera in fibra di poliestere con trattamento idrorepellente
Imbottitura sedile (versione British Standard)	poliuretano sagomato, combinazione fibra Solutex e poliuretano viscoelastico, fodera in fibra di poliestere con trattamento idrorepellente (con cuciture termosaldate)
Cinghiatura sedile	fibra di polipropilene e fili di gomma sintetica
Intreccio	treccia in fibra di polipropilene
Puntali	materiale termoplastico
Telo di copertura impermeabile	tessuto PES monospalmato su un lato PU
Rivestimento	tessuto in categorie limitate (con profilo)
Rivestimento (versione British Standard)	tessuto in categorie limitate (senza profilo)

NE61S_I

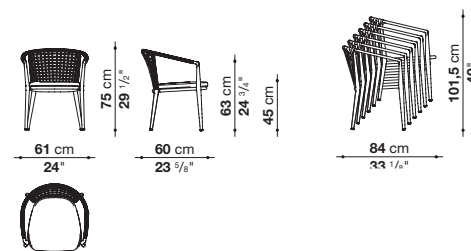
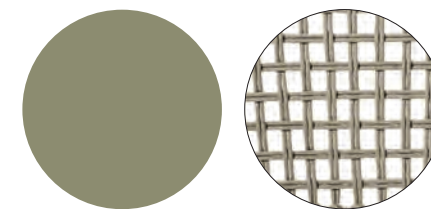
Frame and interlacing matching (NE61S_I)
Abbinamento struttura e intreccio (NE61S_I)

* 0742S
sage painted / natural polypropylene
verniciato salvia / polipropilene naturale

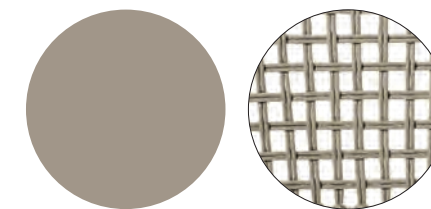

* 0831T
tortora painted / tortora polypropylene
verniciato tortora / polipropilene tortora

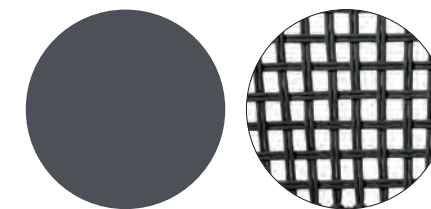

* 0688A
anthracite painted / anthracite polypropylene
verniciato antracite / polipropilene antracite

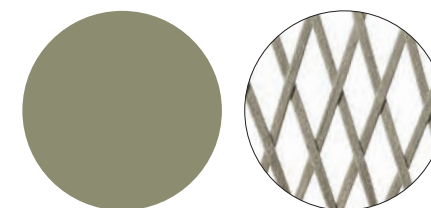
Frame and interlacing matching
Abbinamento struttura e intreccio

* 0702N
sage painted / natural polypropylene
verniciato salvia / polipropilene naturale

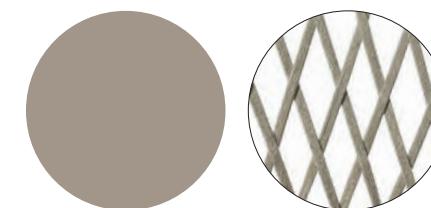

* 0828T
tortora painted / tortora polypropylene
verniciato tortora / polipropilene tortora

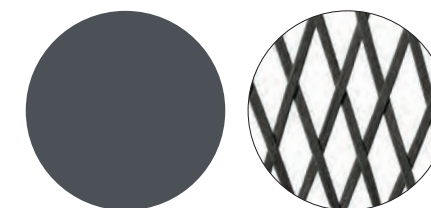

* 0625G
anthracite painted / anthracite polypropylene
verniciato antracite / polipropilene antracite

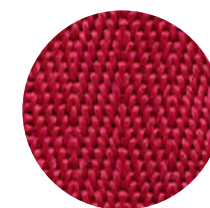
Seat and back cushion profile
Profilo cuscino sedile e schienale

* 0075R
red
rosso

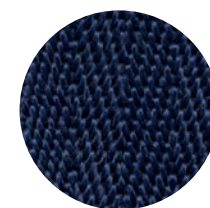

* 0095B
blue
blu

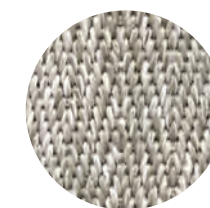

* 0082N
natural
naturale

Fat-Fat Outdoor, Patricia Urquiola - 2019

OTF42

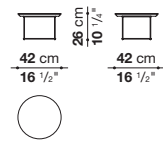

OTF62

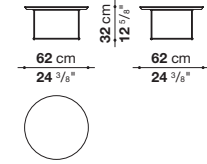

OTF62A

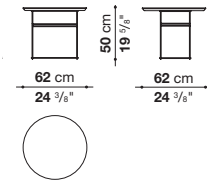

OTF92

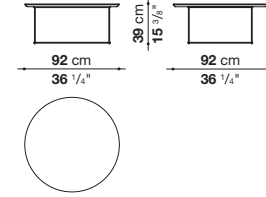

OTF42G

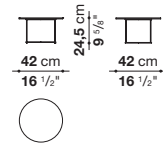

OTF62G

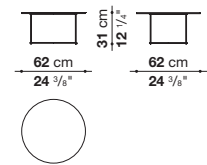

OTF62AG

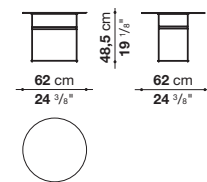

OTF92G

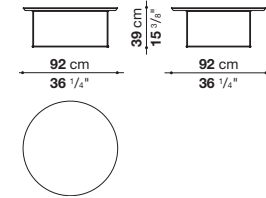

OF42V

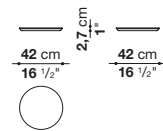

OF62V

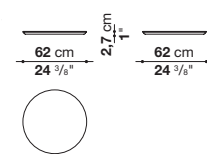

OF92V

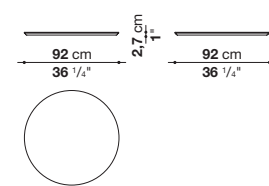

Frame	steel profiles
Top	porcelain stoneware or steel sheet
Tray	steel sheet
Ferrules	thermoplastic material

Struttura	profilati d'acciaio
Piano	gres porcellanato o lamiera d'acciaio
Vassoio	lamiera d'acciaio
Puntali	materiale termoplastico

Frame, top and tray
Struttura, piano e vassoio

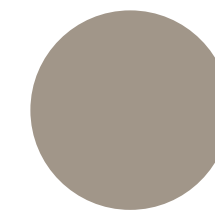

0380T
tortora painted
verniciato tortora

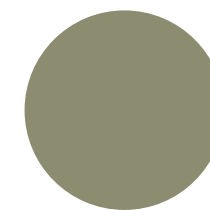

0427S
sage painted
verniciato salvia

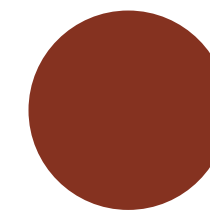

0750A
clay painted
verniciato argilla

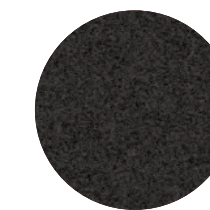

0236B
anthracite painted
verniciato antracite

Top (OTF42G-OTF62G-OTF62AG-OTF92G)
Piano (OFT42G-OFT62G-OFT62AG-OFT92G)

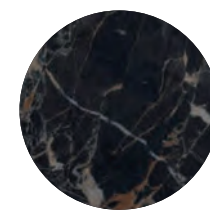

0355N
anthracite stone porcelain stoneware
gres porcellanato pietra antracite

Fat-Sofa Outdoor, Patricia Urquiola - 2015

FA150

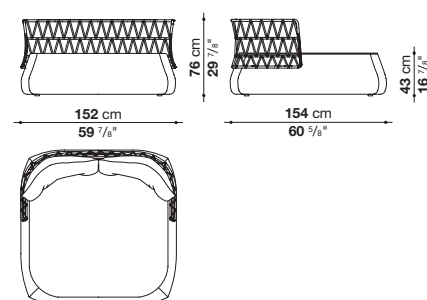

FA91B

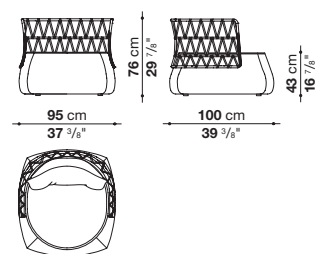

FA61P

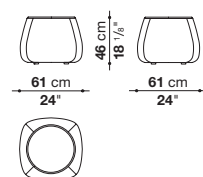

FA230

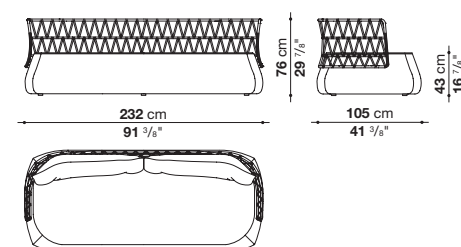

FA91A

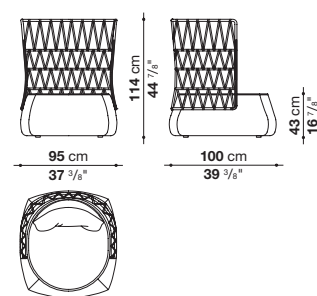

FA76P

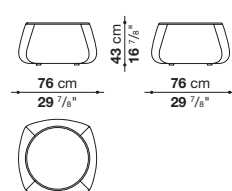

Frame	aluminium with polyester powder painting
Interlacing	polyethylene fibre
Internal frame	tubular steel and steel profiles, polystyrene foam
Internal frame upholstery	Bayfit® (Bayer®) flexible cold shaped polyurethane foam, shaped polyurethane of different density, water repellent polyester fibre cover (with heat-sealed ribbon)
Internal frame (FA61P-FA76P)	polystyrene foam, MDF wood fibre panel with Umidax® high humidity resistance
Internal frame upholstery (FA61P-FA76P)	Bayfit® (Bayer®) flexible cold shaped polyurethane foam, shaped polyurethane, water repellent polyester fibre cover (with heat-sealed ribbon)
Back cushion	polyester fibre, cover in water repellent polyester fibre
Bottom base	100% polyamide fabric coated PVC, PVC trimming
Feet	thermoplastic material
Waterproof cover cloth	PES fabric coated on one side in PU
Cover	fabric in limited categories

Struttura	alluminio con verniciatura a polvere poliesteri
Intreccio	fibra di polietilene
Telaio interno	tubolari e profilati d'acciaio, polistirolo espanso
Imbottitura telaio interno	schiuma di poliuretano flessibile a freddo Bayfit® (Bayer®), poliuretano sagomato a densità differenziata, fodera in fibra di poliestere con trattamento idrorepellente (con cuciture termosaldate)
Telaio interno (FA61P-FA76P)	polistirolo espanso, pannello in fibra di legno MDF ad alta resistenza all'umidità Umidax®
Imbottitura telaio interno (FA61P-FA76P)	schiuma di poliuretano flessibile a freddo Bayfit® (Bayer®), poliuretano sagomato, fodera in fibra di poliestere con trattamento idrorepellente (con cuciture termosaldate)
Cuscino schienale	fibra di poliestere, fodera in fibra di poliestere con trattamento idrorepellente
Fondo	tessuto 100% poliammide spalmato PVC, guarnizione in PVC
Piedini	materiale termoplastico
Telo di copertura impermeabile	tessuto PES monospalmato su un lato PU
Rivestimento	tessuto in categorie limitate

Interlacing Intreccio



* 0612T
tortora polyethylene
polietilene tortora

Frank Outdoor, Antonio Citterio - 2019

OF58P

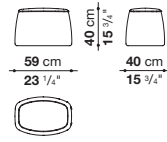

Internal frame	tubular steel and steel profiles
Upholstery	Bayfit® flexible cold shaped polyurethane foam, water repellent polyester fibre cover (with heat-sealed ribbon)
Ferrules	thermoplastic material
Waterproof cover cloth	PES fabric coated on one side in PU
Cover	fabric in limited categories (with profile)

Profile
Profilo

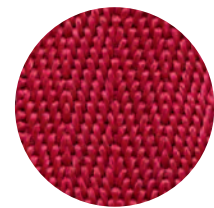

* 0075R
red
rosso

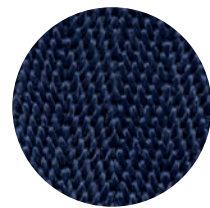

* 0095B
blue
blu

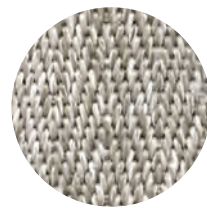

* 0082N
natural
naturale

* Image not in scale / Immagine non in scala

Fiore, Naoto Fukasawa - 2018

TF100RA

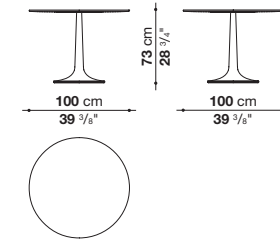

TF100RB

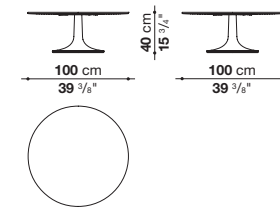

Top and base-frame	cement (Ultra High Performance Concrete)
Coupling plate	galvanized sheet
Ferrules	thermoplastic material

Top and base-frame
Piano e base



* 0159B
white cement
cemento bianco

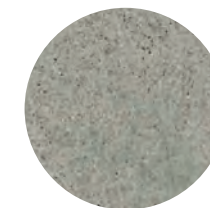

* 0240G
greige cement
cemento greige

* Image not in scale / Immagine non in scala

TF85A

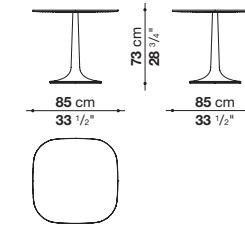

TF85B

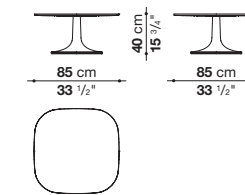

Piano e base	cemento (Ultra High Performance Concrete)
Piastra di aggancio	lamiera zincata
Puntali	materiale termoplastico

Gelso, Antonio Citterio - 2010

TGL105A

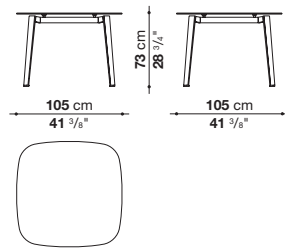

Top	glass
Frame	die-cast aluminium and extrusions with polyester powder painting
Ferrules	thermoplastic material
Waterproof cover cloth	polyester on synthetic support

Top
Piano



0100H
white back painted
etched glass
vetro acidato
retro-verniciato bianco

Frame
Struttura

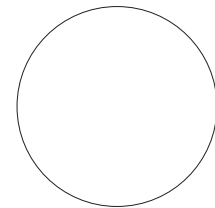

0179A
white painted
verniciato bianco

Piano	vetro
Struttura	fusione ed estrusi d'alluminio con verniciatura a polvere poliestere
Puntali	materiale termoplastico
Telo di copertura impermeabile	poliestere su supporto sintetico

Ginestra, Antonio Citterio - 2017

GN220T

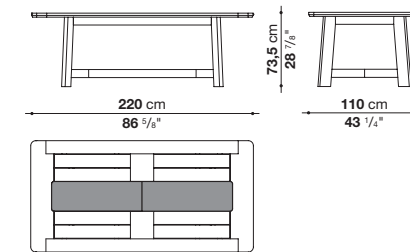

GN60

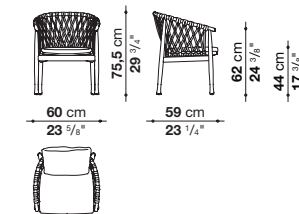

Frame and top	solid wood
Back upholstery	polyester fibre and polyurethane combination
Seat upholstery	shaped polyurethane, Solutex fibre and visco-elastic polyurethane combination, cover in water repellent polyester fibre
Interlacing	polypropylene fibre braid
Top section	porcelain stoneware
Ferrules	thermoplastic material
Waterproof cover cloth	PES fabric coated on one side in PU
Cover	fabric in limited categories

Frame and top
Struttura e piano



0456T
natural teakwood
teak naturale

Top section
Inserto piano

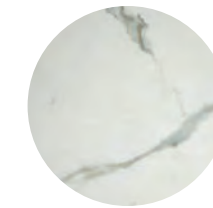

*0301B
Calacatta white
porcelain stoneware
gres porcellanato
bianco Calacatta

GN280T

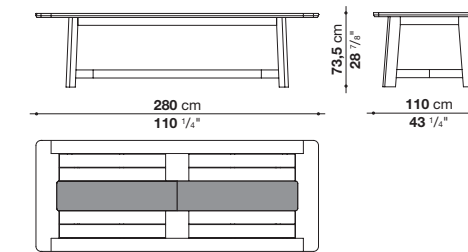

GN180TR

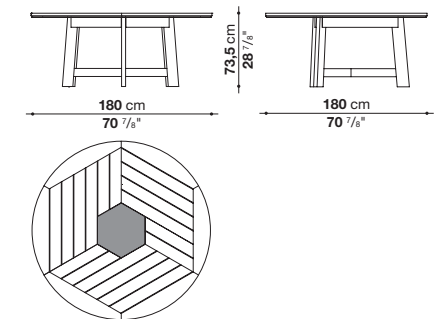

Struttura e piano	legno massello
Imbottitura schienale	combinazione fibra di poliestere e poliuretano
Imbottitura sedile	poliuretano sagomato, combinazione fibra Solutex e poliuretano viscoelastico, fodera in fibra di poliestere con trattamento idrorepellente
Intreccio	treccia in fibra di polipropilene
Inserto piano	gres porcellanato
Puntali	materiale termoplastico
Telo di copertura impermeabile	tessuto PES monospalmato su un lato PU
Rivestimento	tessuto in categorie limitate

Interlacing
Intreccio



*0312B
beige polypropylene
polipropilene beige

Gio, Antonio Citterio - 2016

GO203

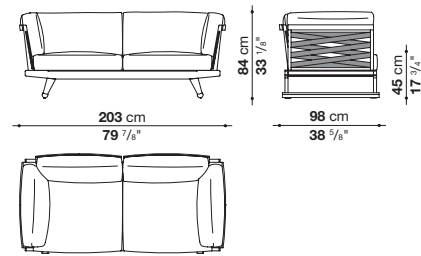

GO192C

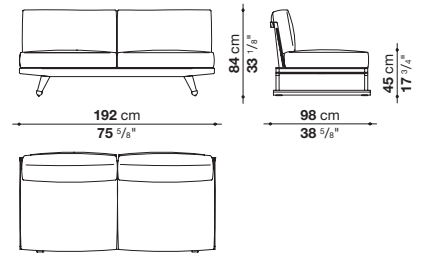

GO203L

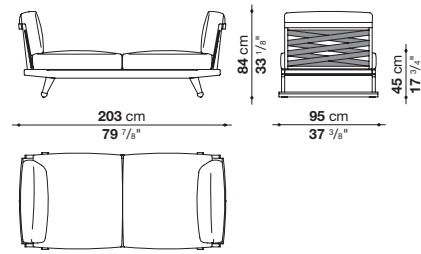

* GO197TD

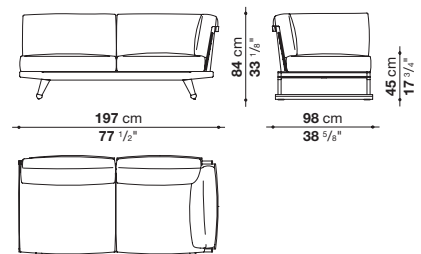

GO238

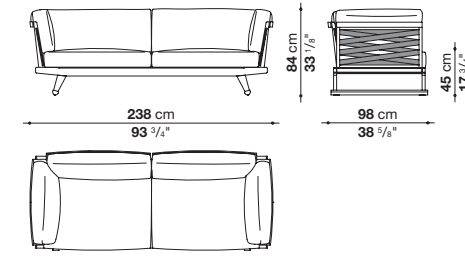

GO227C

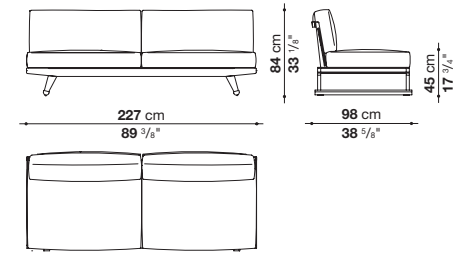

GO238L

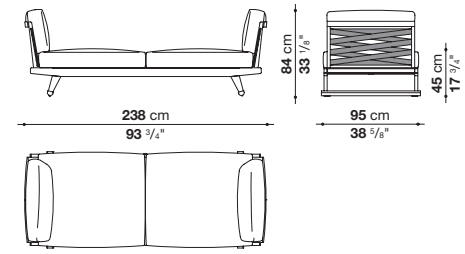

* GO233TD

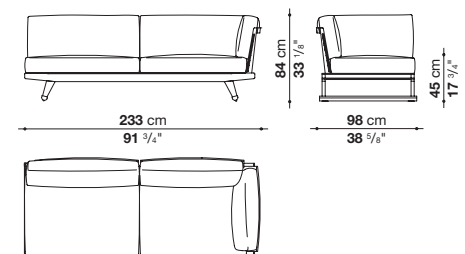

* GO192CD

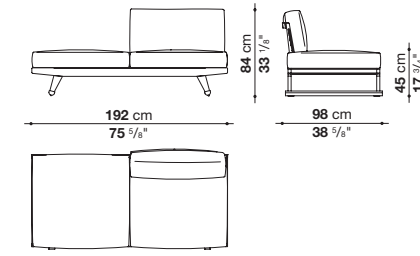

* GO197LD

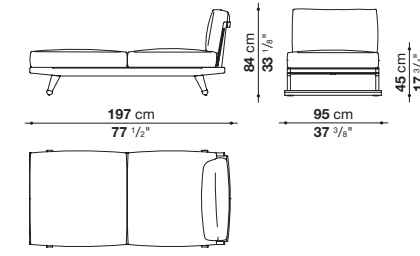

* GO203LD

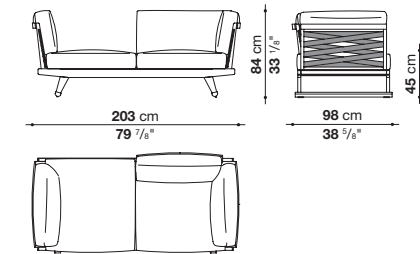

* GO197AD

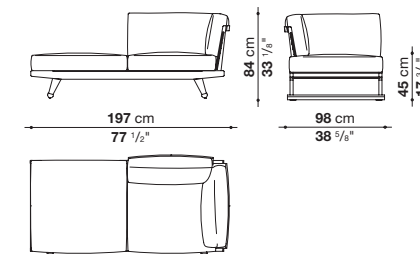

* GO227CD

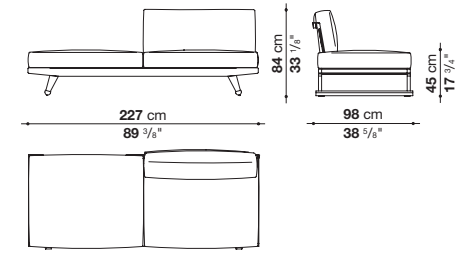

* GO233LD

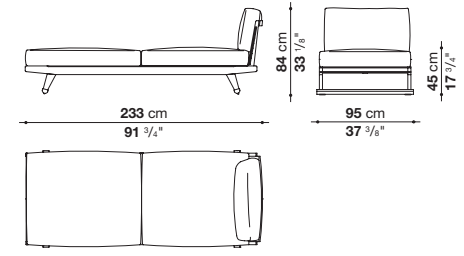

* GO238LD

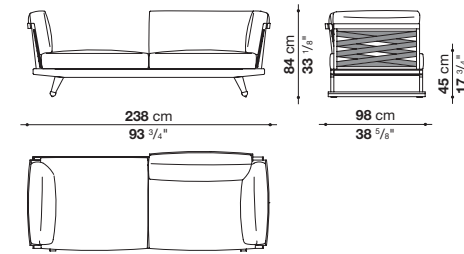

* GO233AD

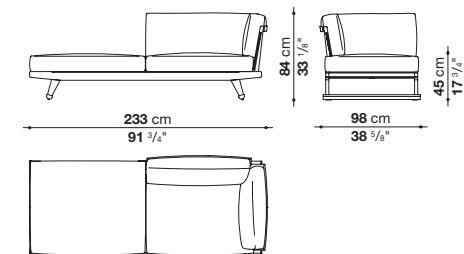

* Elements available in right and left version. / Elementi disponibili nella versione destra e sinistra.

* Elements available in right and left version. / Elementi disponibili nella versione destra e sinistra.

Gio, Antonio Citterio - 2016

GO58

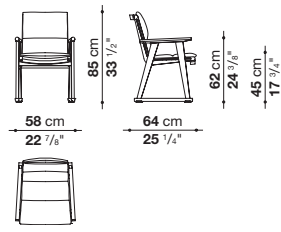

GO64

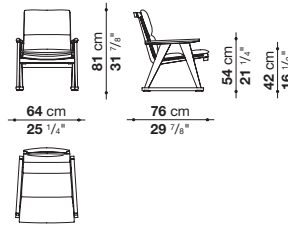

GO65P

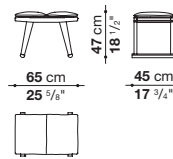

GO130P

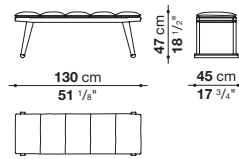

TGO6

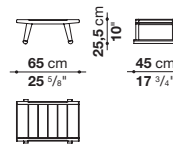

TGO9

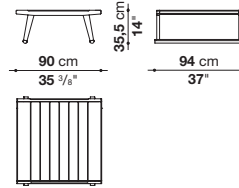

TGO12

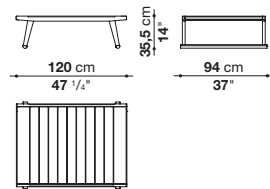

TGO18

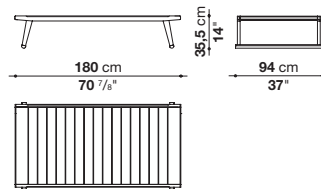

TGO220

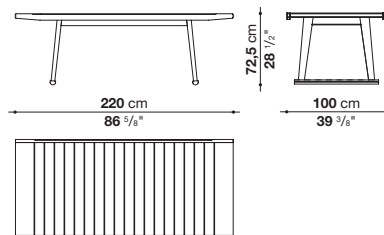

TGO280

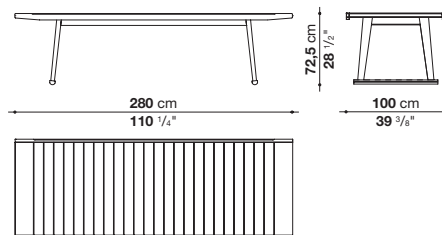

GO200L

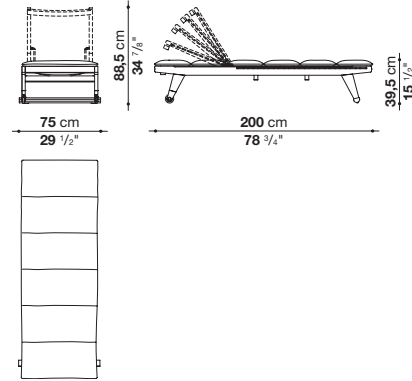

Frame and top	solid wood
Webbing	polypropylene
Upholstery	shaped polyurethane of different density, combination of Solutex fibre and visco-elastic polyurethane, cover in water repellent polyester fibre
Upholstery (GO58-GO64-GO200L-GO65P-GO130P)	high density polyester fibre
Reclining mechanism and zipper (GO200L)	electro polished stainless steel
Wheels (GO200L)	co-moulded thermoplastic material
Wheel supports (GO200L)	die-cast aluminium
Ferrules	thermoplastic material
Waterproof cover cloth	PES fabric coated on one side in PU

Struttura e piano	legno massello
Cinghiatura	polipropilene
Imbottitura	poliuretano sagomato a densità differenziata, combinazione fibra Solutex e poliuretano viscoelastico, fodera in fibra di poliestere con trattamento idrorepellente
Imbottitura (GO58-GO64-GO200L-GO65P-GO130P)	fibra di poliestere ad alta densità
Meccanismo reclinabile e cerniera (GO200L)	acciaio inox elettrolucidato
Ruote (GO200L)	materiale termoplastico co-stampato
Sostegno ruote (GO200L)	alluminio pressofuso
Puntali	materiale termoplastico
Telo di copertura impermeabile	tessuto PES monospalmato su un lato PU

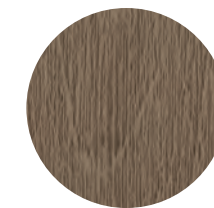
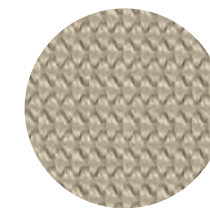
Frame and top
Struttura e piano0492T
antique grey teakwood
teak antique greyWebbing
Cinghiatura* 0113B
tortora polypropylene
polipropilene tortora

Husk Outdoor, Patricia Urquiola - 2011

H2

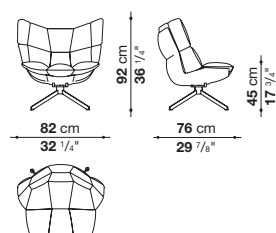

H4

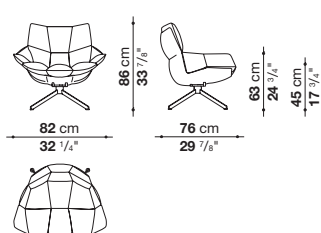

HP1

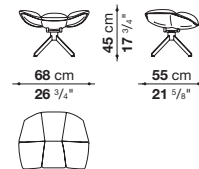

HT

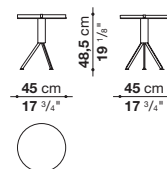

HTO62

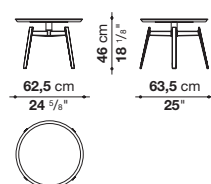

HTO62V

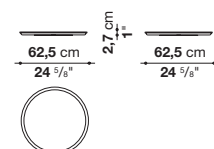

Shell	Hirek® plastic material
Upholstery	polyester fibre, cover in water repellent polyester fibre
Base-frame	aluminium profiles with polyester powder painting
Top (HT)	aluminium sheet with polyester powder painting
Top and tray (HTO62-HTO62V)	steel sheet with polyester powder painting
Support frame (HTO62)	steel sheet and die-cast aluminium with polyester powder painting
Ferrules	plastic material and stainless steel
Ferrules (HTO62)	plastic material
Waterproof cover cloth	PES fabric coated on one side in PU
Cover	fabric in limited categories

Scocca	materiale plastico Hirek®
Imbottitura	fibra di poliestere, fodera in fibra di poliestere con trattamento idrorepellente
Basamento	profilati d'alluminio con verniciatura a polvere poliestere
Piano (HT)	lamiera d'alluminio con verniciatura a polvere poliestere
Piano e vassoio (HTO62-HTO62V)	lamiera d'acciaio con verniciatura a polvere poliestere
Struttura di sostegno (HTO62)	lamiera d'acciaio e fusione d'alluminio con verniciatura a polvere poliestere
Puntali	materiale plastico e acciaio inossidabile
Puntali (HTO62)	materiale plastico
Telo di copertura impermeabile	tessuto PES monospalmato su un lato PU
Rivestimento	tessuto in categorie limitate

Shell
Scocca

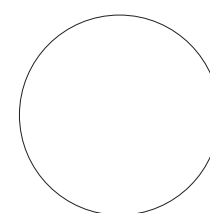

0010B
white Hirek®
Hirek® bianco

Base-frame and tray small table (HTO62 - HTO62V)
Basamento e vassoio tavolino (HTO62 - HTO62V)

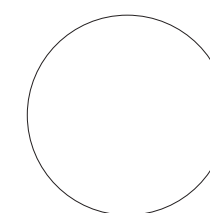

09010
white painted
verniciato bianco

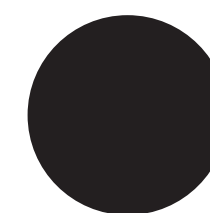

01510
black painted
verniciato nero

Seatings base-frame and small table top (HT)
Basamento sedute e piano tavolino (HT)

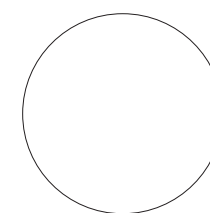

09010
white painted
verniciato bianco

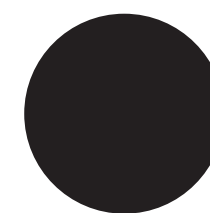

01510
black painted
verniciato nero

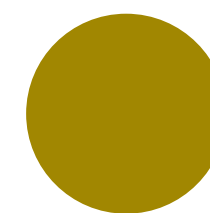

04510
acid green painted
verniciato verde acido

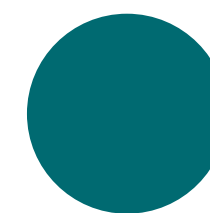

08110
light blue painted
verniciato azzurro

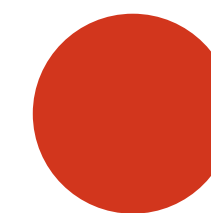

05710
orange painted
verniciato arancio

Husk Outdoor, Patricia Urquiola - 2011

HK1N

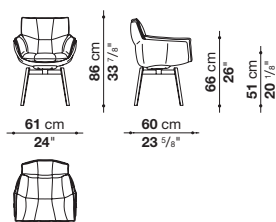

Shell	high density polyurethane resin (Baydur®)
Upholstery	polyester fibre, needle polyester fibre section
Support frame	die-cast aluminium with polyester powder painting
Ferrules	plastic material
Waterproof cover cloth	PES fabric coated on one side in PU
Cover	fabric in limited categories

Scocca	resina poliuretanic ad alta densità (Baydur®)
Imbottitura	fibra di poliestere, inserto in fibra di poliestere agugliato
Struttura di sostegno	fusione d'alluminio con verniciatura a polvere poliestere
Puntali	materiale plastico
Telo di copertura impermeabile	tessuto PES monospalmato su un lato PU
Rivestimento	tessuto in categorie limitate

Shell
Scocca

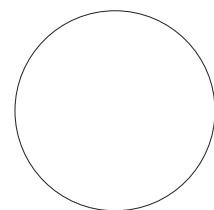

0020B
white Baydur®
Baydur® bianco

Support frame
Struttura di sostegno

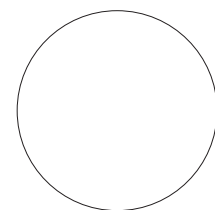

09010
white painted
verniciato bianco

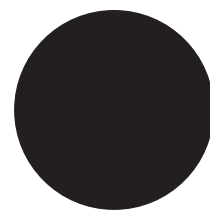

01510
black painted
verniciato nero

Kaleidos, B&B Italia CR&S - 2018

TKA01

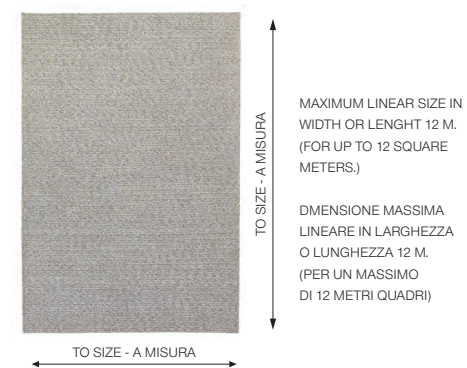

TKA200



TKA250



TKA300



Carpet	braided ropes with dyed Olyna FLYER® fibre
Composition	100% polyolefin

Tappeto	corde intrecciate con fibra tinta Olyna FLYER®
Composizione	100% poliolefine

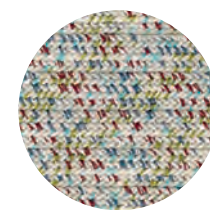

* 0021M
multicolour
multicolore

* The colours and materials shades reproduced on paper is an indication, image not in scale
La tonalità dei colori e dei materiali riprodotta su carta ha un valore indicativo, immagine non in scala

Karam, B&B Italia CR&S - 2019

Table bowls set
Set ciotole da tavolo

KA01

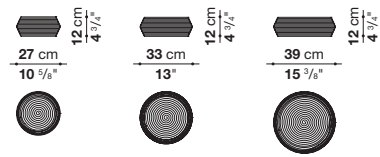

Floor baskets set
Set ceste da terra

KA02

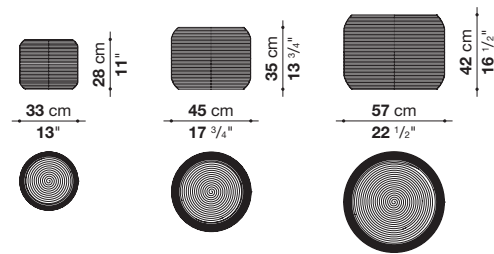

Composition 100% polyolefin

Composizione 100% poliolefine



* 0467V
olive green / pistachio
verde oliva / pistacchio



* 0719B
violet / red
viola / rosso



* 0842B
overseas blue / blue royal
blu oltremare / blu royal



* 0288T
stone / anthracite
sasso / antracite

* The colours and materials shades reproduced on paper is an indication, image not in scale
La tonalità dei colori e dei materiali riprodotta su carta ha un valore indicativo, immagine non in scala

Kyra, B&B Italia CR&S - 2019

TY200

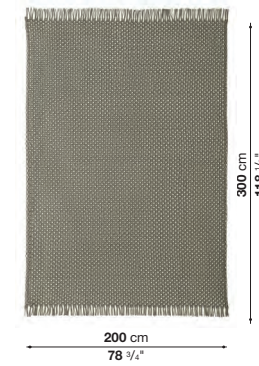

Carpet braided ropes with dyed Olyna FLYER® fibre

Tappeto corde intrecciate con fibra tinta Olyna FLYER®

Composition 100% polyolefin

Composizione 100% poliolefine

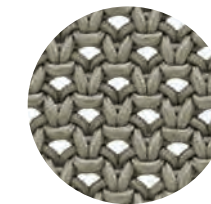

* 0025T
stone
sasso

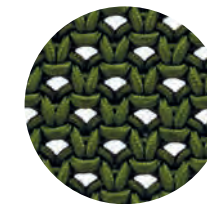

* 0045V
olive green
verde oliva

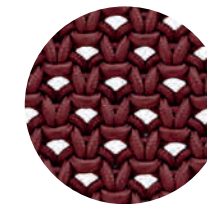

* 0074B
violet
viola

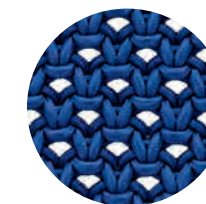

* 0094R
blue royal
blu royal

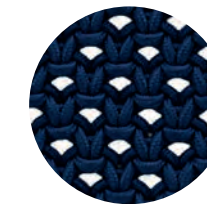

* 0083B
overseas blue
blu oltremare

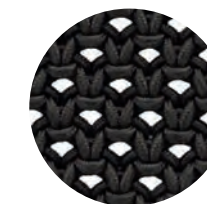

* 0064A
anthracite
antracite

* The colours and materials shades reproduced on paper is an indication, image not in scale
La tonalità dei colori e dei materiali riprodotta su carta ha un valore indicativo, immagine non in scala

Link Outdoor, Jakob Wagner - 2009

TLK190N

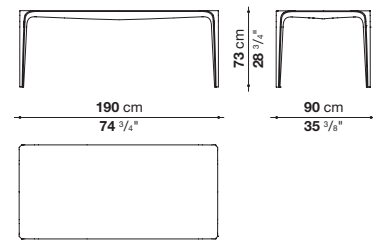

TLK250N

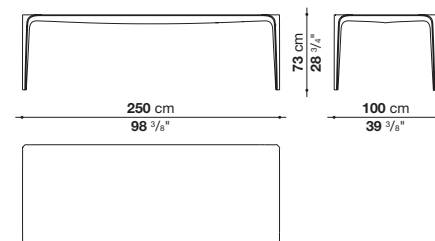
**Top and legs**

Cristalplant Outdoor® (natural mineral filler of phosphate of aluminium with polyester acrylate resin)

Waterproof cover cloth

PES fabric coated on one side in PU

Piano e gambe

Cristalplant Outdoor® (carica minerale naturale di idrato d'alluminio con resina poliestere acrilata)

Telo di copertura impermeabile

tessuto PES monospalmato su un lato PU

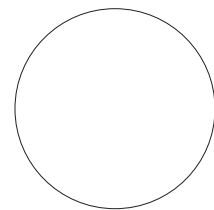
**Top and legs
Piano e gambe**

0101G
white Cristalplant Outdoor®
Cristalplant Outdoor® bianco

Mirto Outdoor, Antonio Citterio - 2013

MI74CL

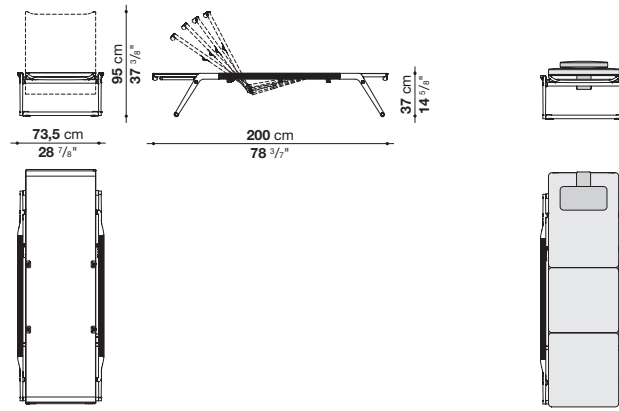

MI200CL

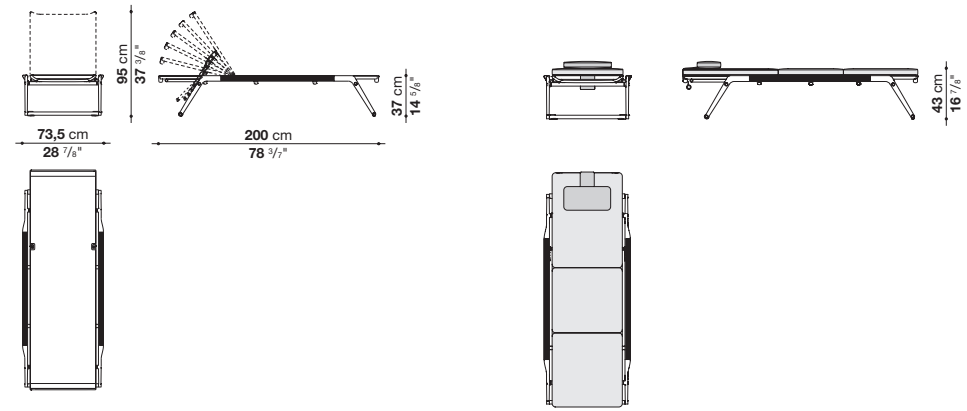

MI74CL_P

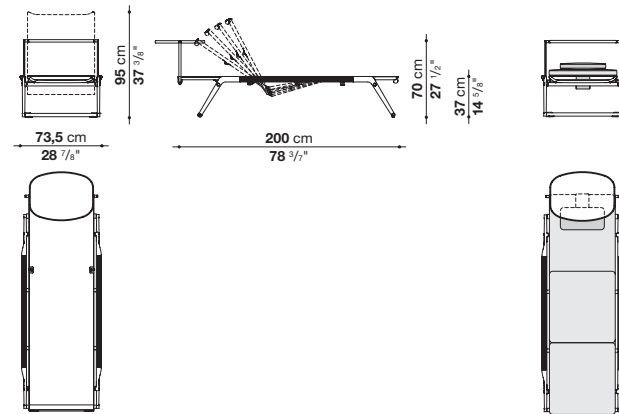

MI200CL_P

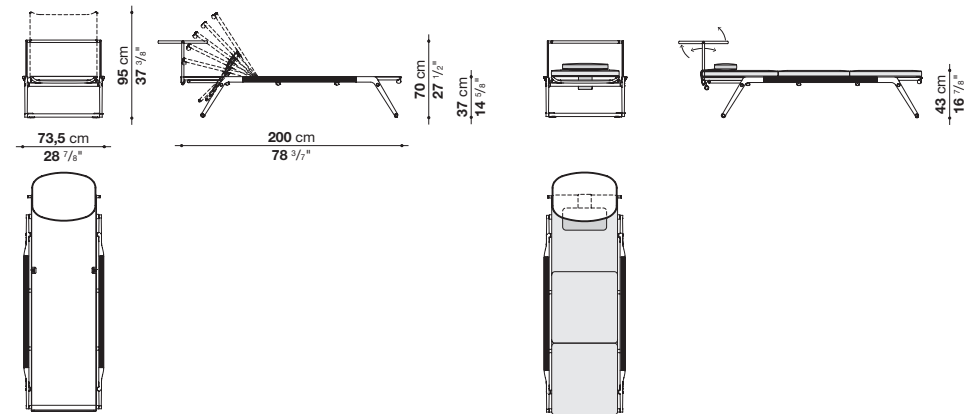

Mirto Outdoor, Antonio Citterio - 2013

MI59N

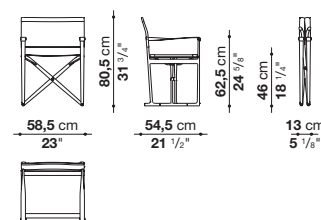

MI59SR

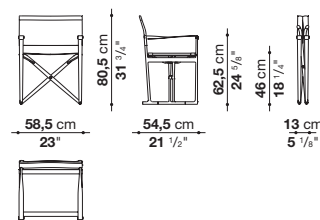

MI58S

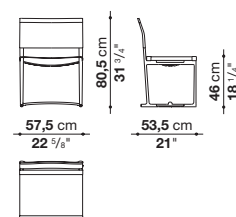

MI65P

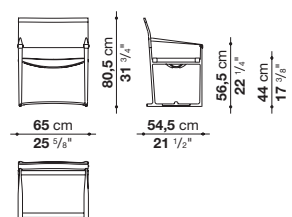

MI54T

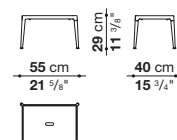

MI55_5

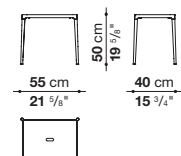

Frame	die-cast aluminium and extrusions with polyurethane painting
Seat and back	Stige mesh in Batyline® Canatex
Seat and back (MI59N)	Laguna fabric
Edges and armrests	Batyline® Keops
Armrests (MI59N)	waterproof thick leather
Wheels (M200CL-MI74CL)	acetal resin
Hinges (M200CL-MI74CL)	micro die-cast stainless steel
Handrail (M200CL-MI74CL)	vulcanised thermoplastic material
Upholstery (small mattress and headrest)	shaped polyurethane polyester fibre cover
Frame and top (MI54T-MI55_5)	die-cast aluminium with polyurethane painting
Ferrules	thermoplastic elastomer
Waterproof cover cloth (M200CL-MI74CL)	PES fabric coated on one side in PU

Struttura	pressofusione ed estrusi d'alluminio con verniciatura poliuretanic
Sedile e schienale	rete Stige in Batyline® Canatex
Sedile e schienale (MI59N)	tessuto Laguna
Bordi e braccioli	Batyline® Keops
Braccioli (MI59N)	cuoio impermeabile
Ruote (M200CL-MI74CL)	resina acetica
Cerniere (M200CL-MI74CL)	microfusione d'acciaio inossidabile
Corrimano (M200CL-MI74CL)	materiale termoplastico vulcanizzato
Imbottitura (materassino e poggiatesta)	poliuretano sagomato, fodera in fibra di poliestere
Piano e struttura (MI54T-MI55_5)	pressofusione d'alluminio con verniciatura poliuretanic
Puntali	elastomero termoplastico
Telo di copertura impermeabile (M200CL-MI74CL)	tessuto PES monospalmato su un lato PU

Frame (MI59N)
Struttura (MI59N)

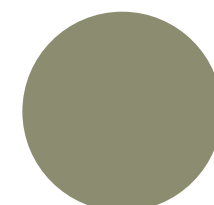

0427S
sage painted
verniciato salvia

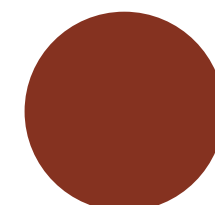

0750A
clay painted
verniciato argilla

Seat and back (MI59N)
Sedile e schienale (MI59N)

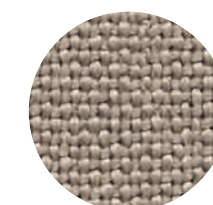

2572102
Laguna fabric
tessuto Laguna

Armrests (MI59N)
Braccioli (MI59N)

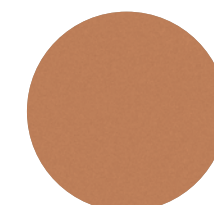

0136N
natural color waterproof thick leather
cuoio impermeabile colore naturale

Frame
Struttura

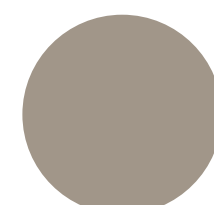

0380T
tortora painted
verniciato tortora

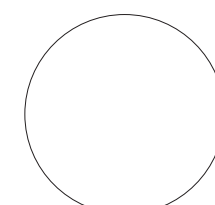

0186V
white painted
verniciato bianco

Seat and back
Sedile e schienale

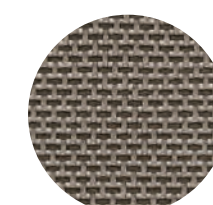

2445280
tortora Stige fabric
tessuto Stige tortora

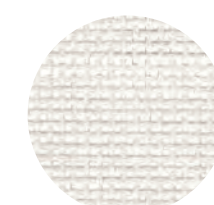

2445102
natural white Stige fabric
tessuto Stige bianco naturale

Edge and armrests
Bordi e braccioli

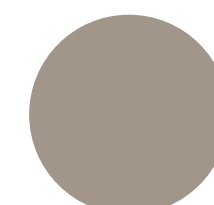

0280T
tortora colour
colore tortora

Small mattress
Materassino

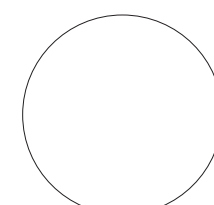

* all available fabrics
tutti i tessuti disponibili

Small mattress and headrest cushion terry cloths
Fodera materassino e cuscino poggiatesta



2375100
White Bali fabric
tessuto Bali bianco

Top and frame (MI54T - MI55_5)
Struttura e piano tavolini (MI54T - MI55_5)

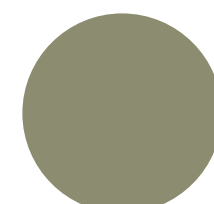

0427S
sage painted
verniciato salvia

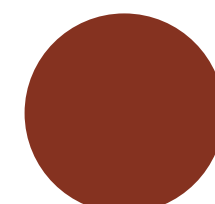

0750A
clay painted
verniciato argilla

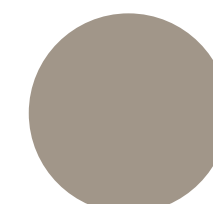

0380T
tortora painted
verniciato tortora

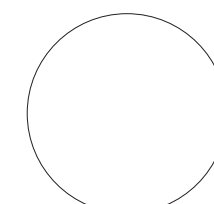

0186V
white painted
verniciato bianco



0236B
anthracite painted
verniciato antracite

Attention: for the specific finishes matched at each product code, please refer to the relevant price list notes)
Attenzione: per le finiture specifiche associate ad ogni singolo codice prodotto fare riferimento alle relative note del listino prezzi

Mirto Outdoor, Antonio Citterio - 2013

Painted or porcelain stoneware top
Piano verniciato o in gres porcellanato

MI90T - MI90TG

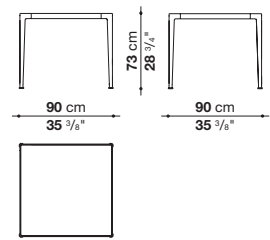

MI150TQ - MI150TQG

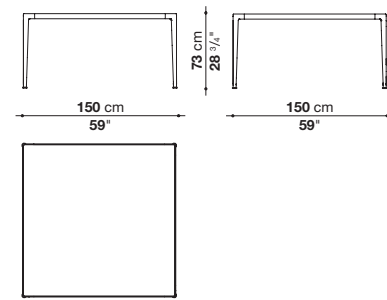

MI160T - MI160TG

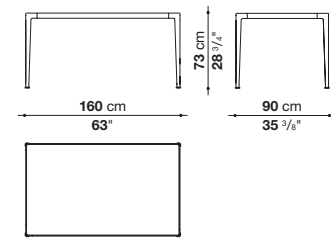

Iroko wood slats top
Piano in doghe di legno Iroko

MI90TL

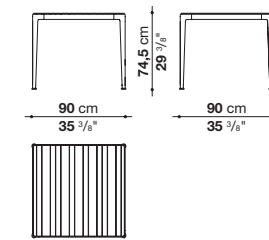

MI150TQL

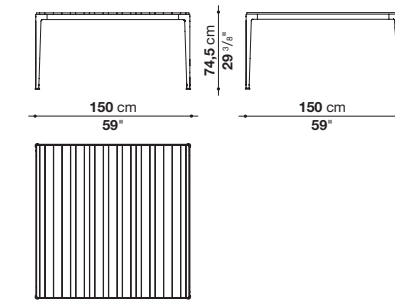

MI160TL

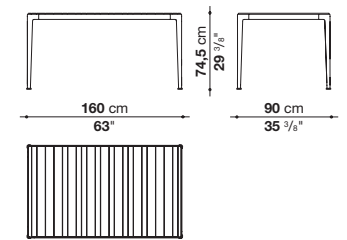

MI220T - MI220TG

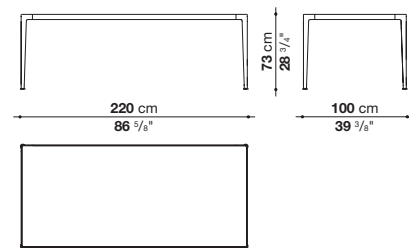

MI250T - MI250TG

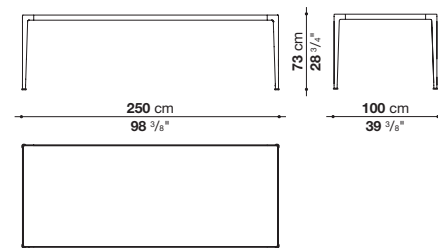

MI220TL

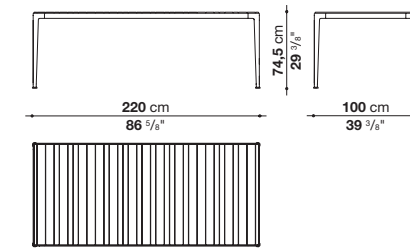

MI250TL

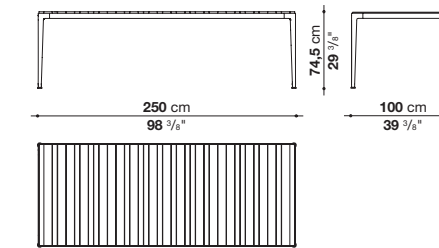

MI150_6 - MI150_6G

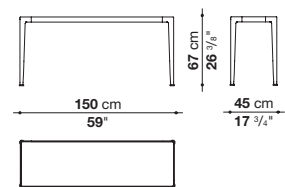

MI200_6 - MI200_6G

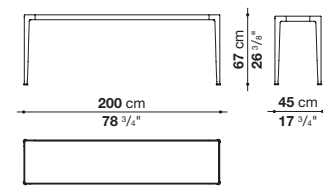

MI250_6 - MI250_6G

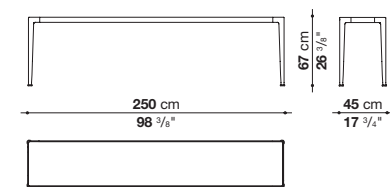

MI150_6L

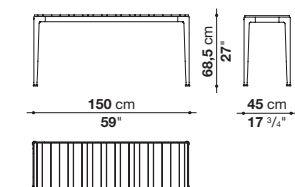

MI200_6L

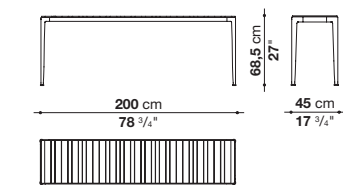

MI250_6L

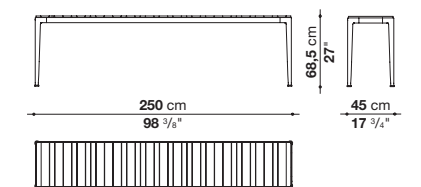

MI90Q_4 - MI90Q_4G

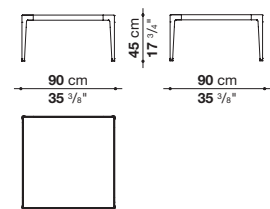

MI120Q_4 - MI120Q_4G

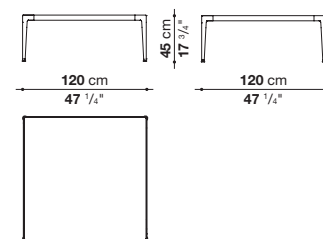

MI120_4 - MI120_4G

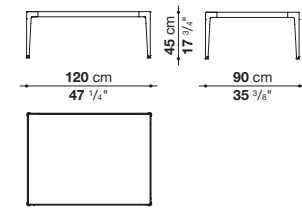

MI90Q_4L

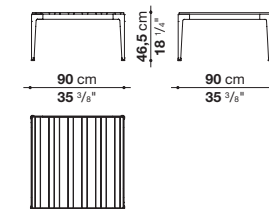

MI120Q_4L

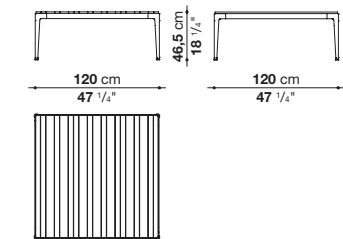

MI120_4L

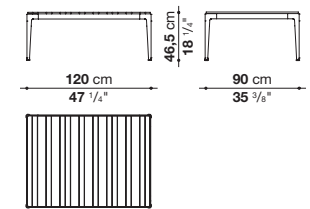

MI180_4 - MI180_4G

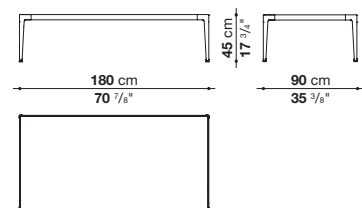

MI200_4 - MI200_4G

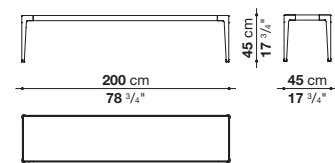

MI180_4L

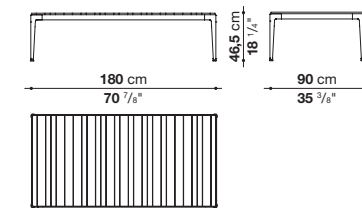

MI200_4L

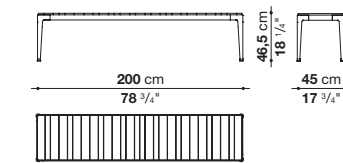

Mirto Outdoor, Antonio Citterio - 2013

Enamelled lava stone with decoration top
Piano in pietra lavica smaltata con decoro

TMO162Q

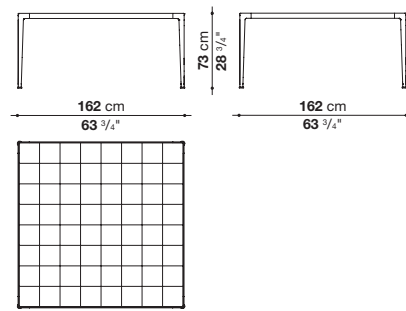

TMO222

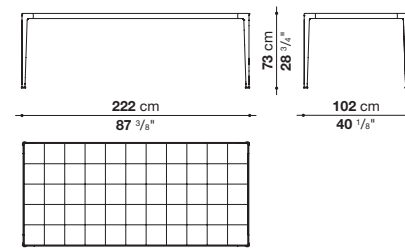

TMO162_6

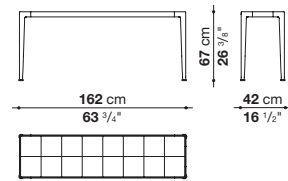

TMO82Q_4

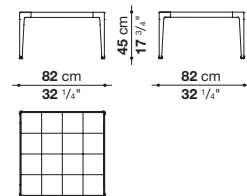

TMO162_4

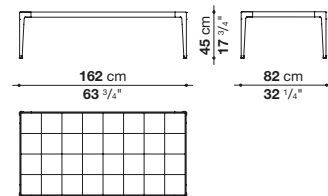

Frame	die-cast aluminium and extrusions with polyurethane painting
Top	aluminium sheet with polyurethane painting, porcelain stoneware, wooden slats or enamelled lava stone
Ferrules	thermoplastic elastomer
Waterproof cover cloth	PES fabric coated on one side in PU

Struttura	pressofusione ed estrusi d'alluminio con verniciatura poliuretanic
Piano	lamiera d'alluminio con verniciatura poliuretanic, gres porcellanato, doghe di legno o pietra lavica smaltata su piano in alluminio
Puntali	elastomero termoplastico
Telo di copertura impermeabile	tessuto PES monospalmato su un lato PU

Tables, small tables and console frame Struttura tavoli, tavolini e console

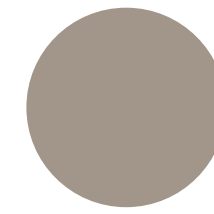

0380T
tortora painted
verniciato tortora

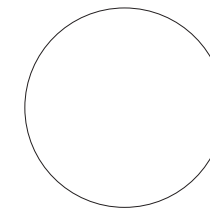

0186V
white painted
verniciato bianco

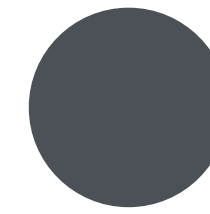

0236B
anthracite painted
verniciato antracite

Tables, small tables and console top Piano tavoli, tavolini e console

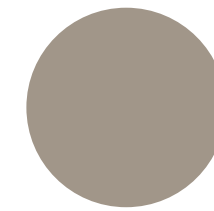

0380T
tortora painted
verniciato tortora

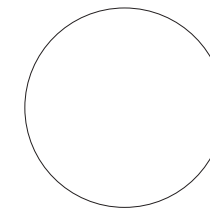

0186V
white painted
verniciato bianco

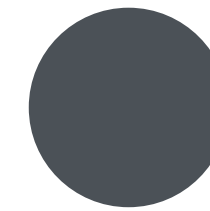

0236B
anthracite painted
verniciato antracite



0405I
brushed natural Iroko wood
Iroko naturale spazzolato



0301B
Calacatta white porcelain stoneware
gres porcellanato bianco Calacatta

Frame and top matching (TMO162Q - TMO222 - TMO162_6 - TMO82Q_4 - TMO162_4) Abbinamento struttura e piano (TMO162Q - TMO222 - TMO162_6 - TMO82Q_4 - TMO162_4)

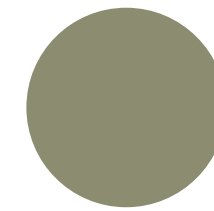

0427S / * 0406V
sage painted / enamelled lava stone with green decoration
verniciato salvia / pietra lavica smaltata con decoro verde



0750A / * 0703A
clay painted / enamelled lava stone with clay decoration
verniciato argilla / pietra lavica smaltata con decoro argilla

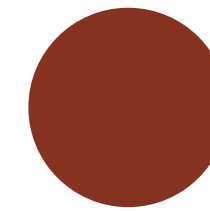

0236B / * 0164A
anthracite painted / enamelled lava stone with anthracite decoration
verniciato antracite / pietra lavica smaltata con decoro antracite



* Image not in scale / Immagine non in scala

Attention: for the specific finishes matched at each product code, please refer to the relevant price list notes

Attenzione: per le finiture specifiche associate ad ogni singolo codice prodotto fare riferimento alle relative note del listino prezzi

Overscale Flames Outdoor, Jean-Marie Massaud - 2008

AB20043B

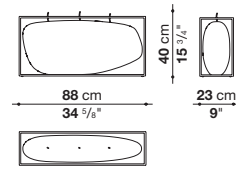

AB20044B

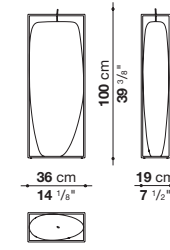

Frame	metal profiles
Shell	high density polyurethane resin (Baydur®)
Nozzles	anodized aluminium

Struttura	profili metallici
Corpo	resina poliuretanică ad alta densitate (Baydur®)
Ugelli	alluminio anodizzato

Frame and shell Struttura e corpo

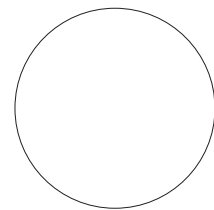

white
bianco

Papilio Shell Outdoor, Naoto Fukasawa - 2016

OSH1

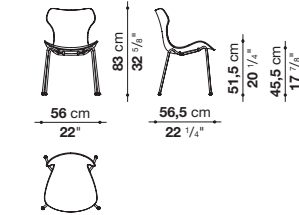

Shell	polypropylene
Support frame	stainless steel profiles
Ferrules	thermoplastic material

Scocca	polipropilene
Struttura di sostegno	profilati d'acciaio inossidabile
Puntali	materiale termoplastico

Support frame Struttura di sostegno

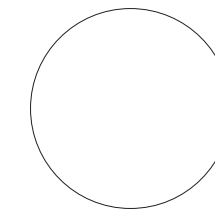

09010
white painted
verniciato bianco

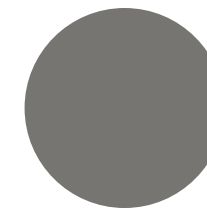

0792T
greige painted
verniciato greige

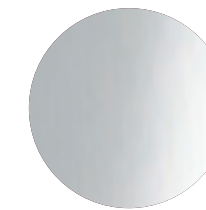

0772C
stainless steel
acciaio inox

Shell Scocca

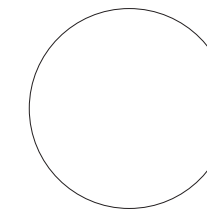

0116B
white polypropylene
polipropilene bianco

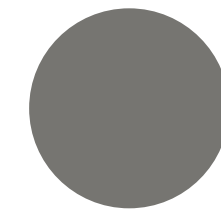

0235G
greige polypropylene
polipropilene greige

Ray Outdoor Fabric, Antonio Citterio - 2017

RF235

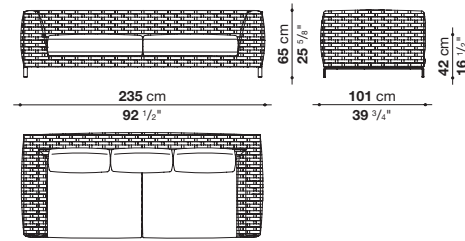

RFL235

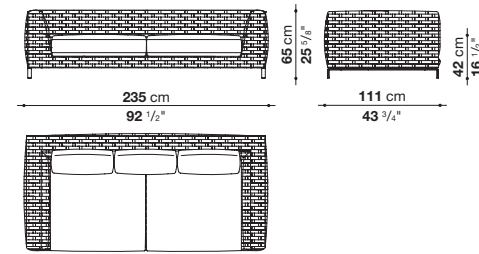

Wooden base
Base legno

RF235_B

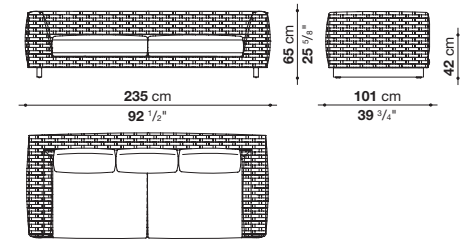

RFL235_B

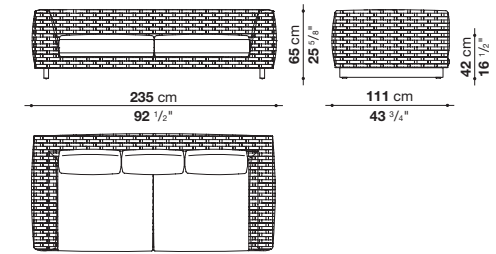

* RF161D

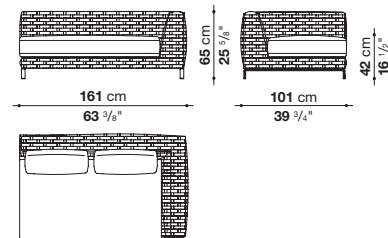

* RF235D

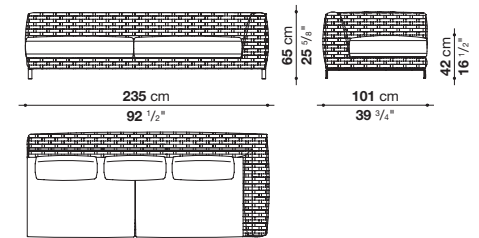

* RF161D_B

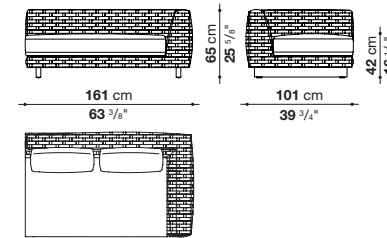

* RF235D_B

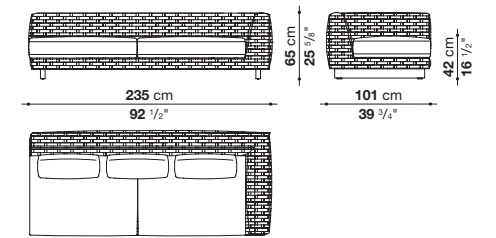

* RF161LD

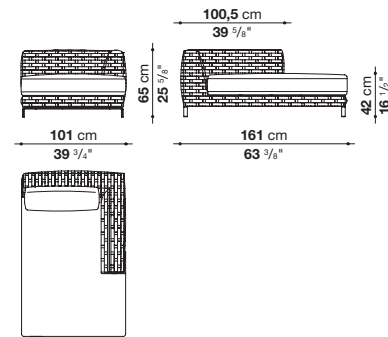

* RF235LD

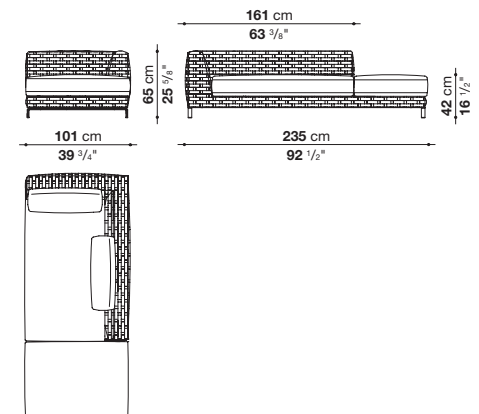

* RF161LD_B

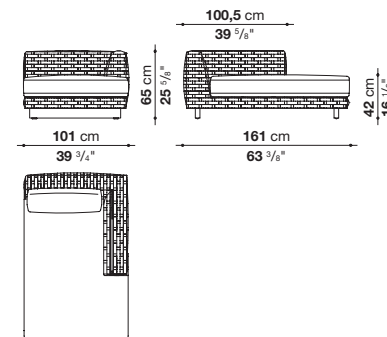

* RF235LD_B

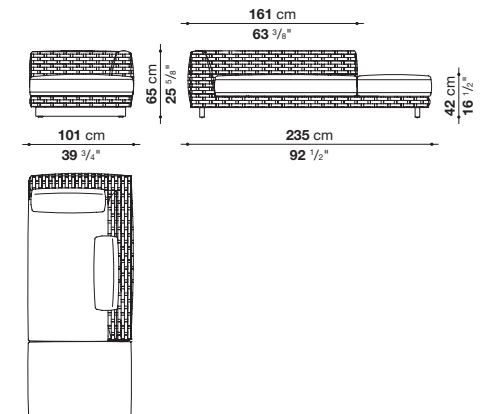

RF85

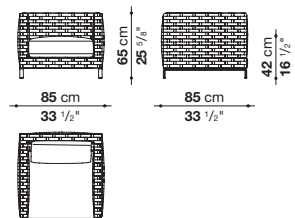

RF203LA

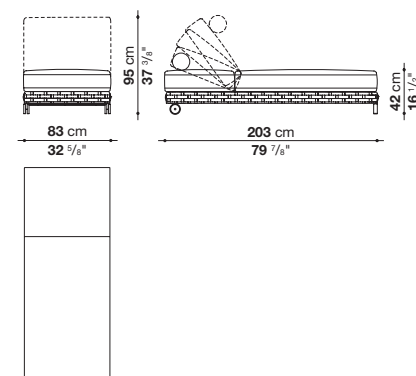

RF85_B

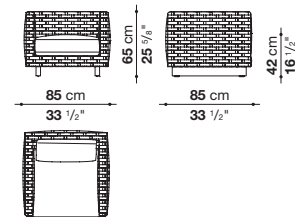

RF203LA_B

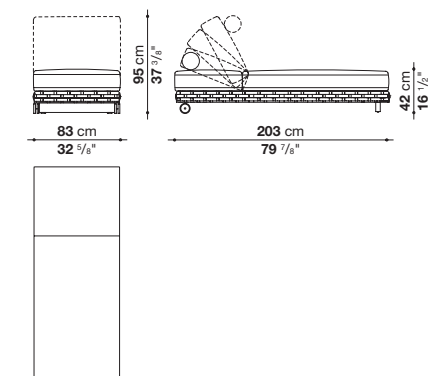

* Elements available in right and left version. / Elementi disponibili nella versione destra e sinistra.

* Elements available in right and left version. / Elementi disponibili nella versione destra e sinistra.

Ray Outdoor Fabric, Antonio Citterio - 2017

Internal frame	tubular aluminium and aluminium profiles with polyester powder painting
Upholstery	shaped polyurethane, Solutex fibre and visco-elastic polyurethane combination, cover in water repellent polyester fibre
Back cushion	polyester fibre, cover in water repellent polyester fibre
Interlacing	polypropylene fibre braid
Headrest cushion (RF203LA)	shaped polyurethane, cover in water repellent polyester fibre
Seat top (RF203LA)	HPL stratified laminate panel
Mechanism (RF203LA)	aluminium extrusion
Wheels (RF203LA)	steel and thermoplastic material
Feet	die-cast aluminium and extrusions with polyester powder painting
Base-frame	solid wood
Ferrules	thermoplastic material
Waterproof cover cloth	PES fabric coated on one side in PU
Cover	fabric in limited categories

Telaio interno	tubolari e profilati d'alluminio con verniciatura a polvere poliestere
Imbottitura	poliuretano sagomato, combinazione fibra Solutex e poliuretano viscoelastico, fodera in fibra di poliestere con trattamento idrorepellente
Cuscino schienale	fibra di poliestere, fodera in fibra di poliestere con trattamento idrorepellente
Intreccio	treccia in fibra di polipropilene
Cuscino poggiatesta (RF203LA)	poliuretano sagomato, fodera in fibra di poliestere con trattamento idrorepellente
Piano sedile (RF203LA)	pannello in laminato stratificato HPL
Meccanismo (RF203LA)	estruso d'alluminio
Ruote (RF203LA)	acciaio e materiale termoplastico
Piedini	fusione ed estrusi d'alluminio con verniciatura a polvere poliestere
Base	legno massello
Puntali	materiale termoplastico
Telo di copertura impermeabile	tessuto PES monospalmato su un lato PU
Rivestimento	tessuto in categorie limitate

Interlacing Intreccio



* 0787T
turquoise polypropylene
polipropilene turchese



* 0880B
blue polypropylene
polipropilene blu



* 0640V
acid green polypropylene
polipropilene verde acido



* 0577B
bordeaux polypropylene
polipropilene bordeaux



* 0428T
tortora polypropylene
polipropilene tortora

Feet Piedini

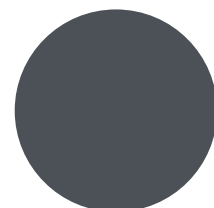

0236B
anthracite painted
verniciato antracite



0492T
antique grey teakwood
teak antique grey

Base-frame Base

* Image not in scale / Immagine non in scala

Ray Outdoor Natural, Antonio Citterio - 2017

RN236

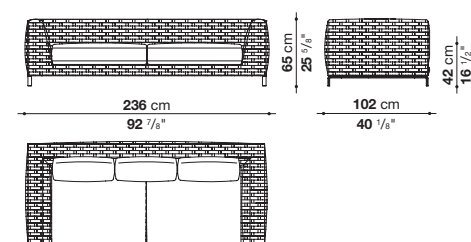

* RN236D

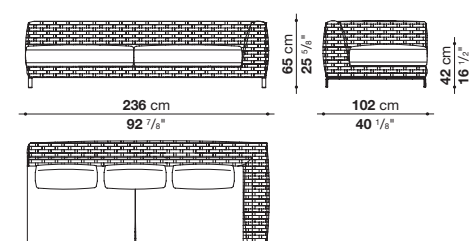

RNL236

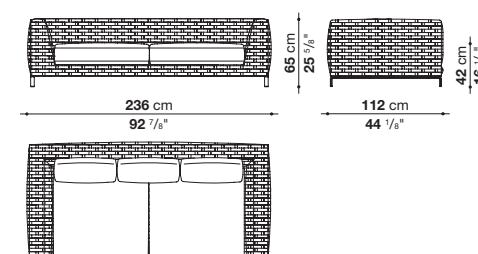

* RN236LD

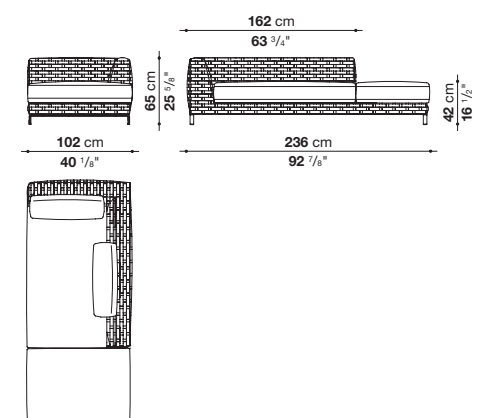

RN86

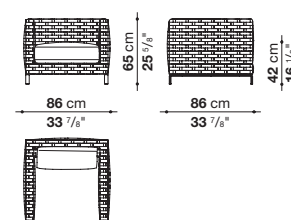

* Elements available in right and left version. / Elementi disponibili nella versione destra e sinistra.

Ray Outdoor Natural, Antonio Citterio - 2017

Wooden base
Base legno

RN236_B

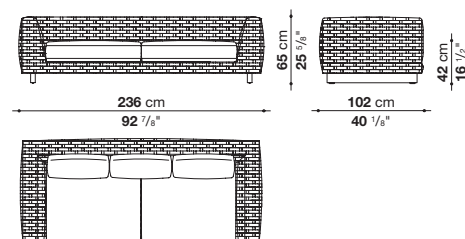

* RN236D_B

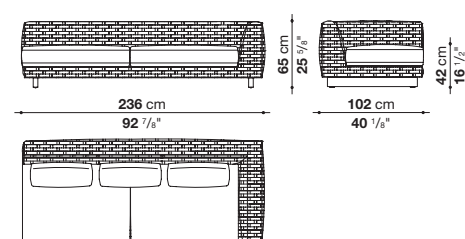

RN86_B

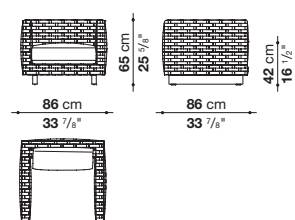

RNL236_B

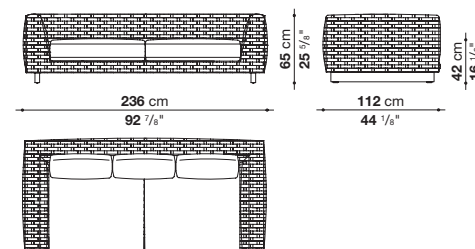

* RN236LD_B

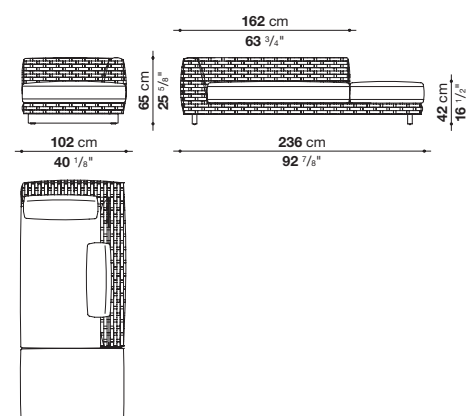

Internal frame	tubular aluminium and aluminium profiles with polyester powder painting
Upholstery	shaped polyurethane, Solutex fibre and visco-elastic polyurethane combination, cover in water repellent polyester fibre
Back cushion	polyester fibre, cover in water repellent polyester fibre
Interlacing	textilene braid
Feet	die-cast aluminium and extrusions with polyester powder painting
Base-frame	solid wood
Ferrules	thermoplastic material
Waterproof cover cloth	PES fabric coated on one side in PU
Cover	fabric in limited categories

Telaio interno	tubolari e profilati d'alluminio con verniciatura a polvere poliestere
Imbottitura	poliuretano sagomato, combinazione fibra Solutex e poliuretano viscoelastico, fodera in fibra di poliestere con trattamento idrorepellente
Cuscino schienale	fibra di poliestere, fodera in fibra di poliestere con trattamento idrorepellente
Intreccio	treccia in textilene
Piedini	fusione ed estrusi d'alluminio con verniciatura a polvere poliestere
Base	legno massello
Puntali	materiale termoplastico
Telo di copertura impermeabile	tessuto PES monospalmato su un lato PU
Rivestimento	tessuto in categorie limitate

Interlacing
Intreccio



* 0528N
natural colour textilene
textilene color naturale

Feet
Piedini

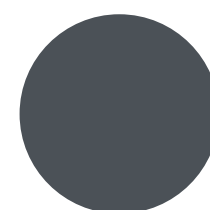

0236B
anthracite painted
verniciato antracite

Base-frame
Base



0492T
antique grey teakwood
teak antique grey

Ravel, Patricia Urquiola - 2008

R90

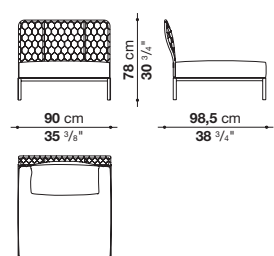

R150

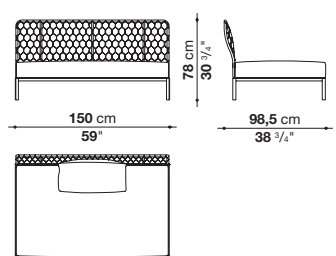

* R150D

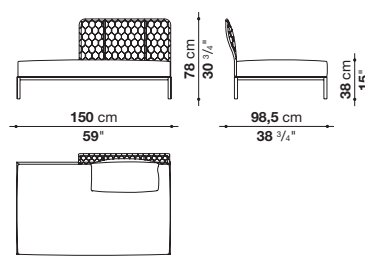

R160

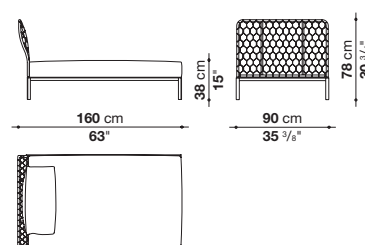

* R100A1D

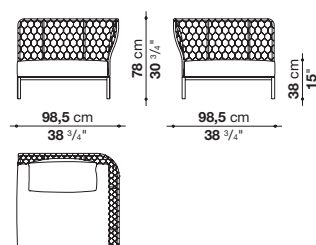

* R100A2D

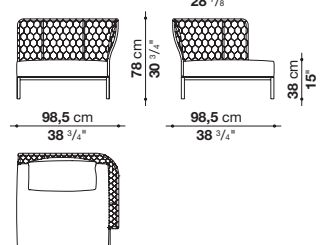

* R160A3D

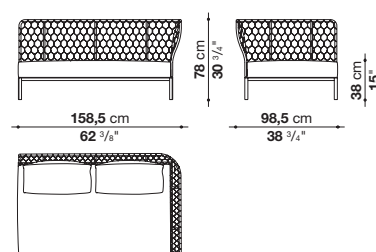

* R160A4D

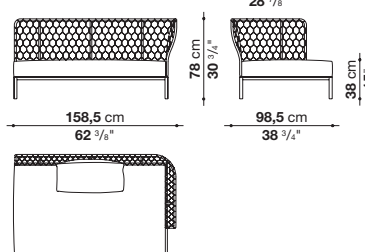

* R100CHD

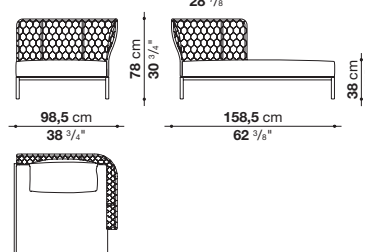

* R160A5D

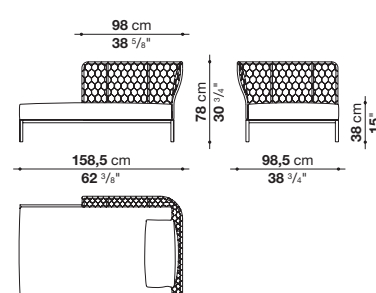

* R160A6D

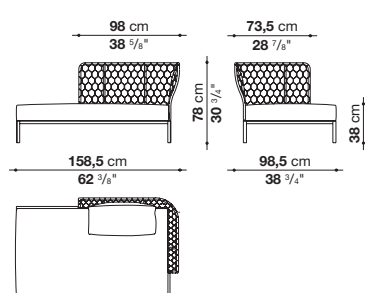

R90P

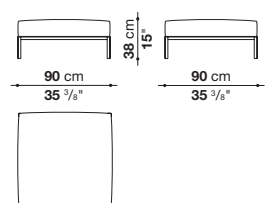

R150P

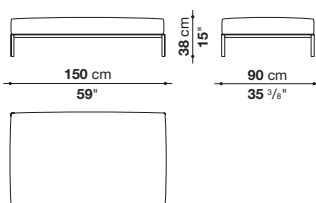

TR90

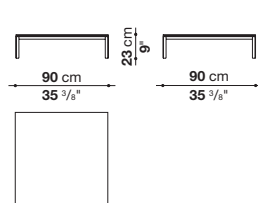

Back	aluminium with polyester powder painting
Frame	galvanized steel with polyester powder painting
Interlacing	polyethylene fibre
Seat cushion	shaped polyurethane, cover in water repellent polyester fibre
Back cushion	polyester fibre, cover in water repellent polyester fibre (with heat-sealed ribbon)
Service element top (TR90)	HPL laminate
Ferrules	thermoplastic material
Waterproof cover cloth	PES fabric coated on one side in PU
Cover	fabric in limited categories

Schienale	alluminio con verniciatura a polvere poliesteri
Struttura	acciaio zincato con verniciatura a polvere poliesteri
Intreccio	fibra di polietilene
Cuscino sedile	poliuretano sagomato, fodera in fibra di poliesteri con trattamento idrorepellente
Cuscino schienale	fibra di poliesteri, fodera in fibra di poliesteri con trattamento idrorepellente (con cuciture termosaldate)
Piano elemento di servizio (TR90)	laminato HPL
Puntali	materiale termoplastico
Telo di copertura impermeabile	tessuto PES monospalmato su un lato PU
Rivestimento	tessuto in categorie limitate

Frame and interlacing matching Abbinamento struttura e intreccio



* 0411P
white painted / tortora polyethylene
verniciato bianco / polietilene tortora

* 0511P
black painted / tortora polyethylene
verniciato nero / polietilene tortora

Frame (TR90)
Struttura (TR90)

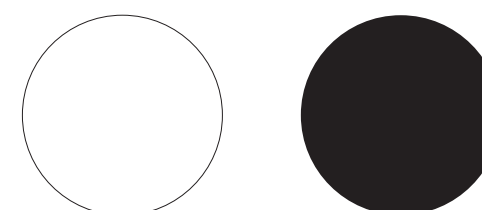

0179A
white painted
verniciato bianco

09005
black painted
verniciato nero

TOP (TR90)
Piano (TR90)

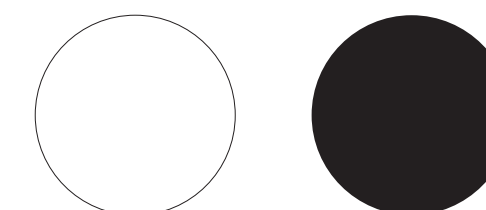

0450M
white HPL laminate
laminato HPL bianco

0399M
black HPL laminate
laminato HPL nero

* Elements available in right and left version. / Elementi disponibili nella versione destra e sinistra.

* Image not in scale / Immagine non in scala

Ribes, Antonio Citterio - 2019

Sofas
Divani

RB212

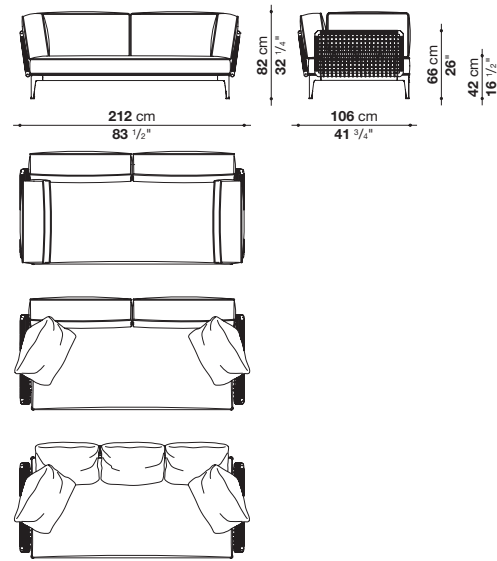

RB248

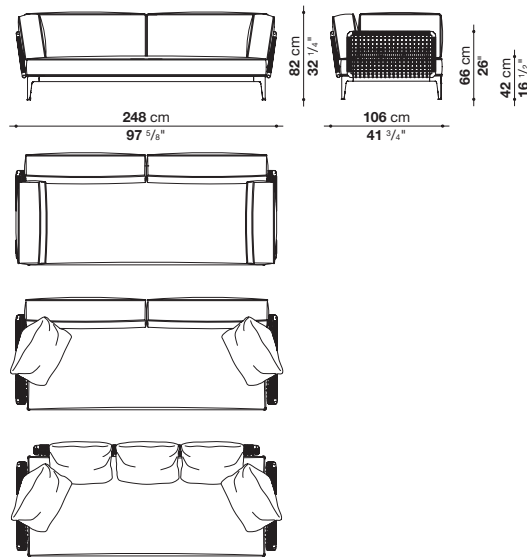

Central elements
Elementi centrali

RB190C

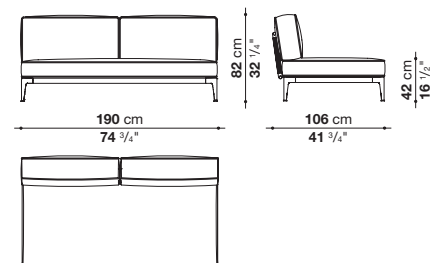

RBR220

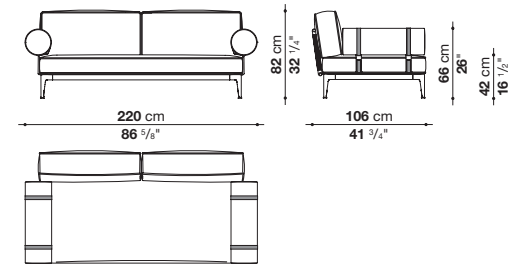

RBR256

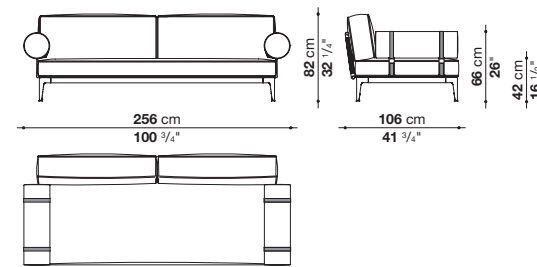

RBR190C

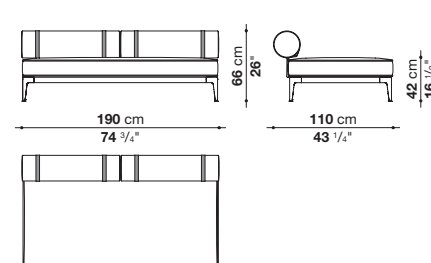

Benches
Panche

RB190PA_1

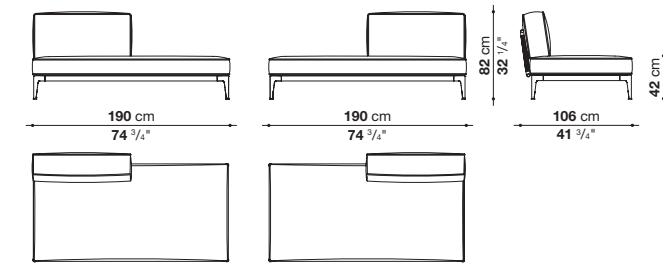

RB190PA_2

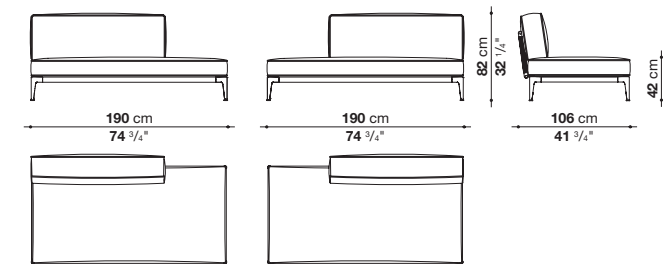

Terminal elements
Elementi terminali

RB201T_1

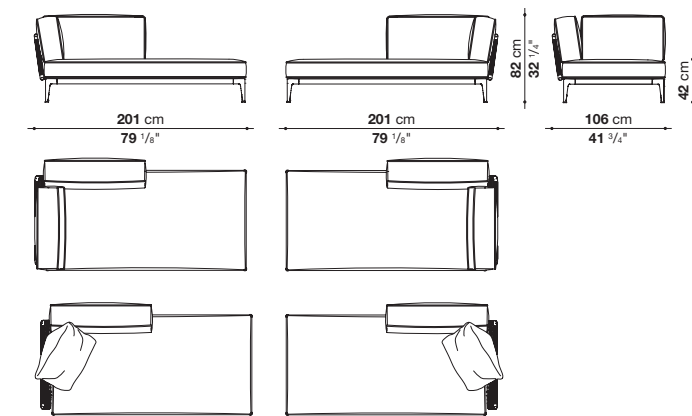

RBR190PA

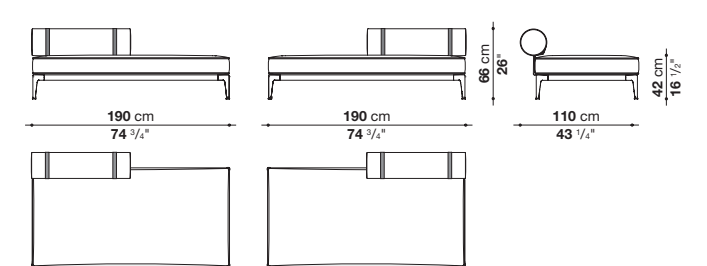

RBR205T_1

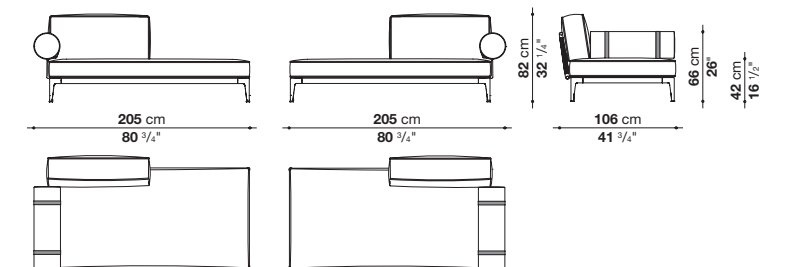

Ribes, Antonio Citterio - 2019

Terminal elements
Elementi terminali

RB201T_2

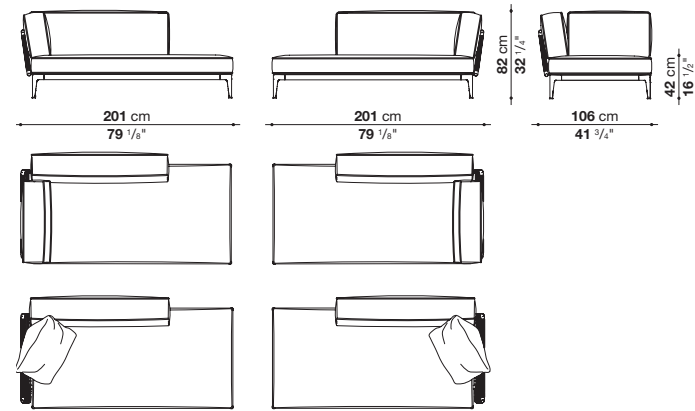

RBR205T_2

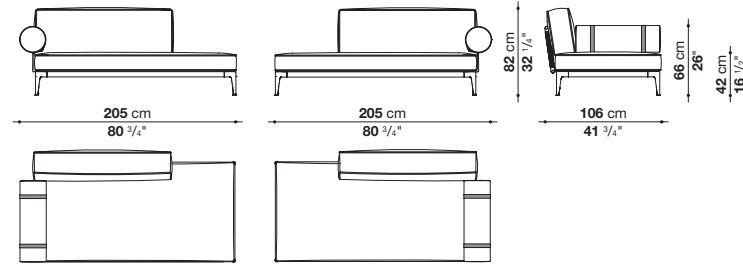

Chaise longue
Chaise longue

RB141L_1

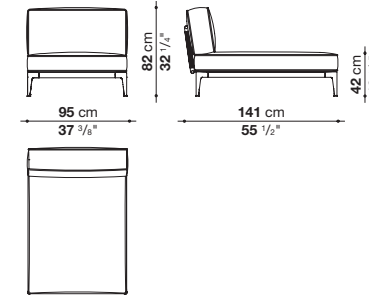

RBR145L

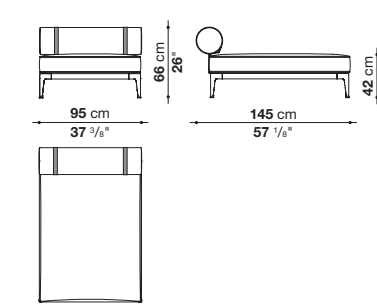

RB141L_2

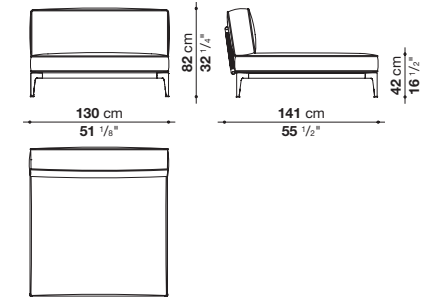

RB201T_3

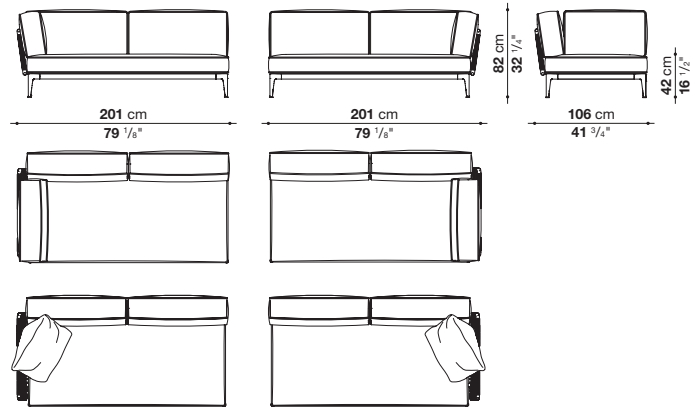

RBR205T_3

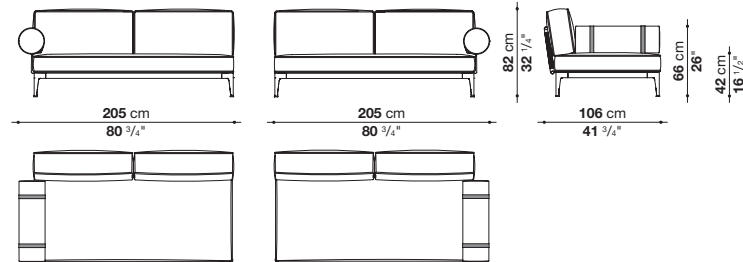

RB201L

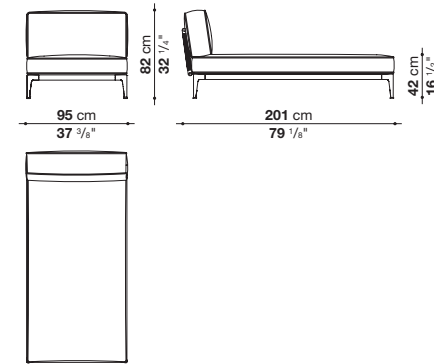

RBR205L

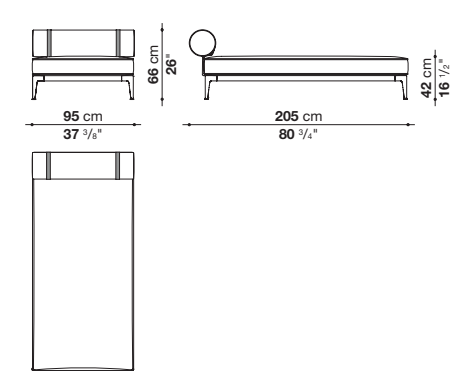

RBR145LB_1

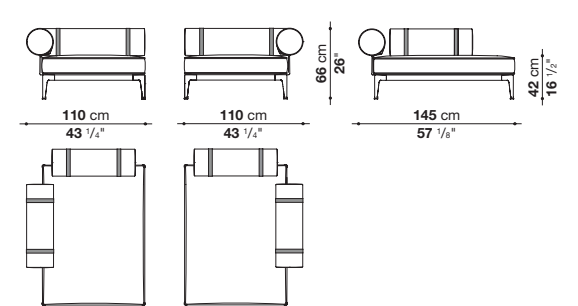

RBR205T_4

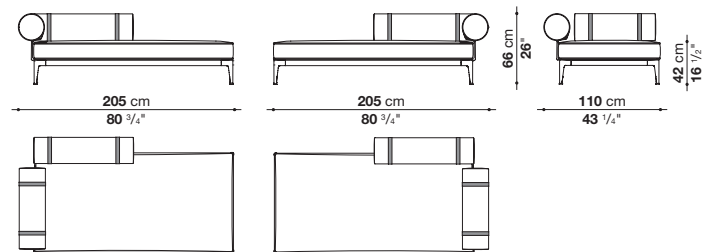

RB141LB_1

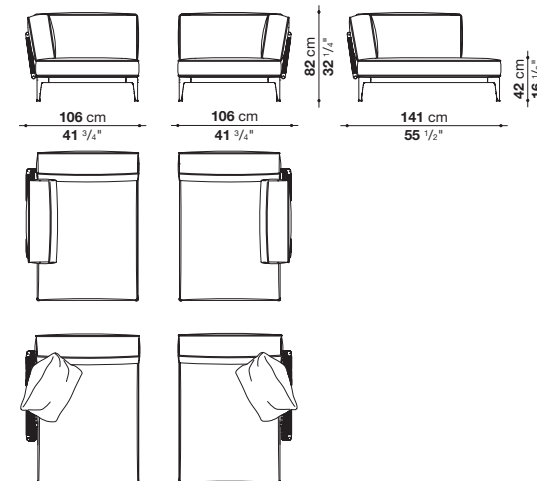

RBR141LB_1

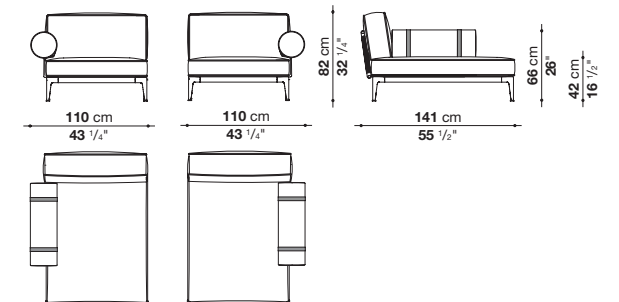

Ribes, Antonio Citterio - 2019

Chaise longue
Chaise longue

RB141LB_3

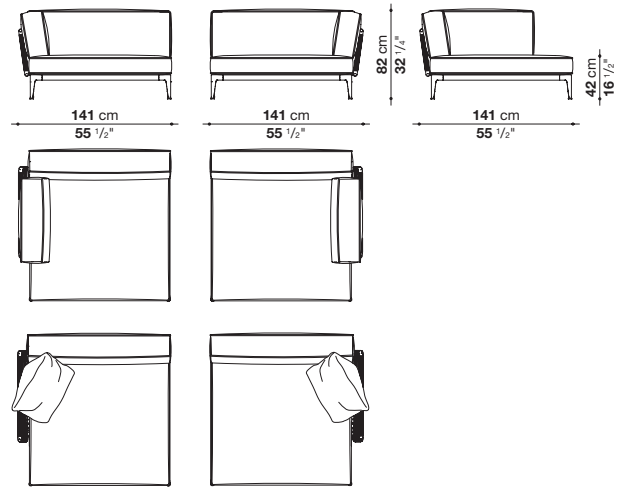

RBR145LB_2

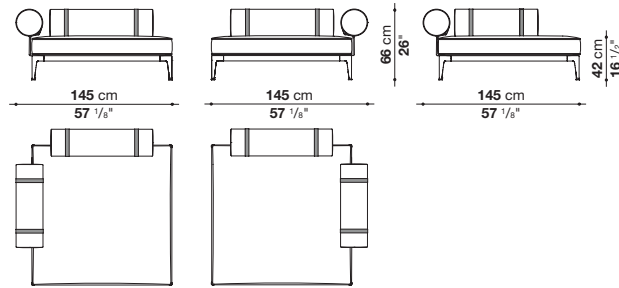

RB201LB_1

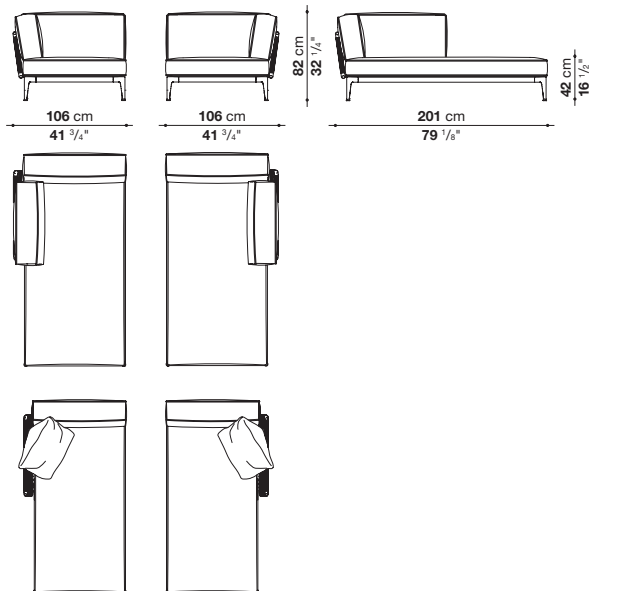

RBR141LB_2

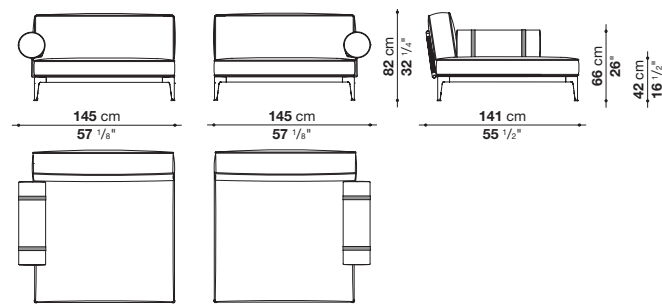

RBR201LB

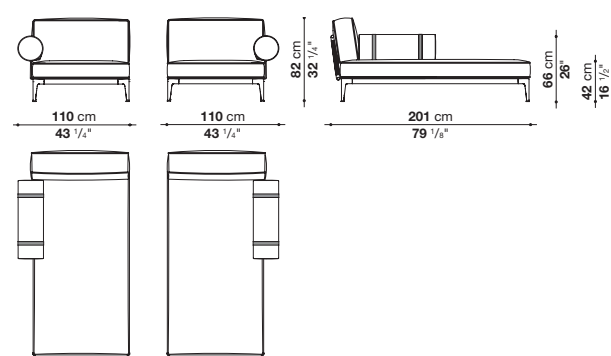

Chaise longue
Chaise longue

RB201LB_2

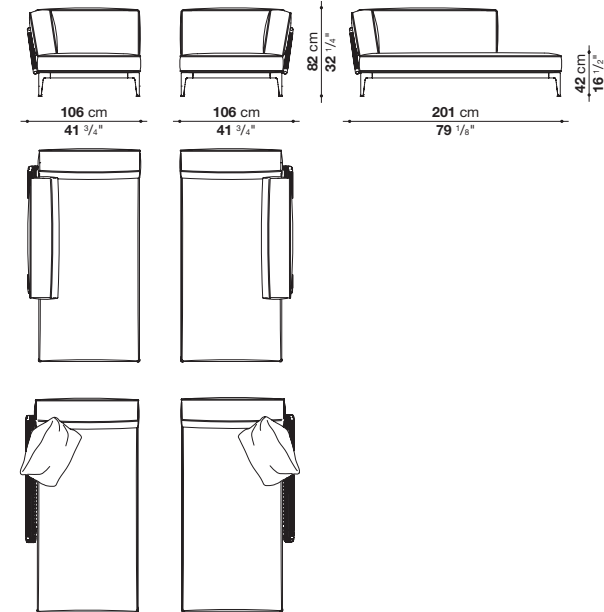

RB141LB_4

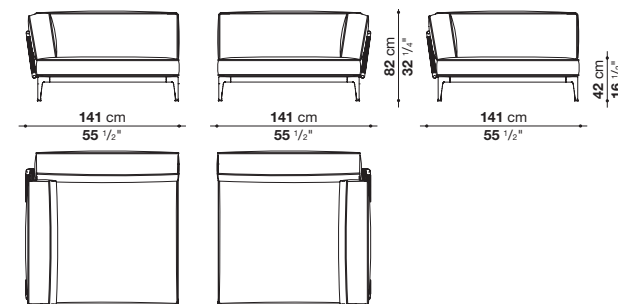

Ottomans
Pouf

RB130P_1

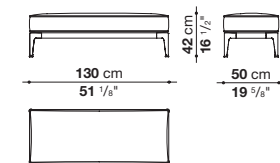

RB130P_2

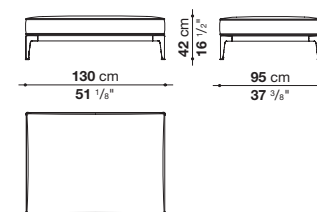

RB130PQ

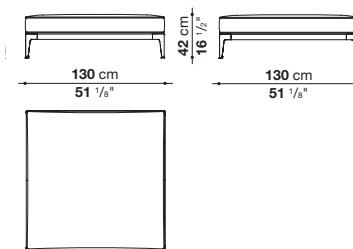

RB190P

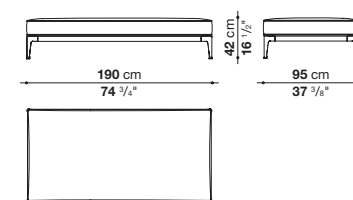

RB141LB_2

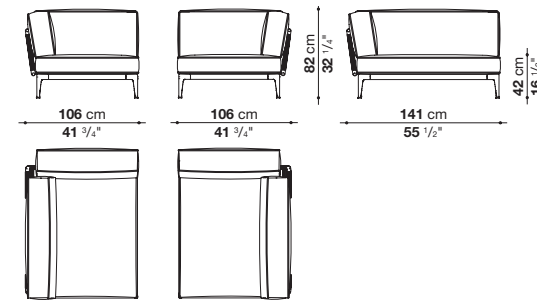

Ribes, Antonio Citterio - 2019

Frame	die-cast aluminium and extrusions with polyester powder painting
Back and roller upholstery	ecogreen (polyethylene and polyester blend), cover in water repellent polyester fibre
Seat upholstery	shaped polyurethane, ecogreen (polyethylene and polyester blend), cover in water repellent polyester fibre
Interlacing	polypropylene fibre braid
Seat slats	glass fibre
Ferrules	thermoplastic material
Waterproof cover cloth	PES fabric coated on one side in PU
Cover	fabric in limited categories (with profile)

Frame Struttura

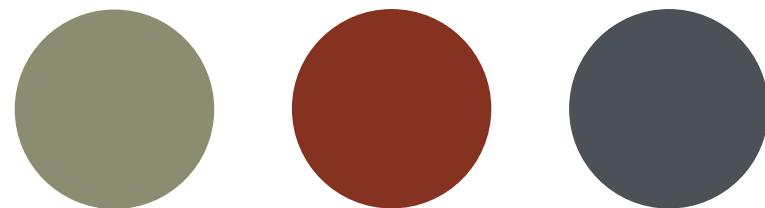

0427S
sage painted
verniciato salvia

0750A
clay painted
verniciato argilla

0236B
anthracite painted
verniciato antracite

Seat, back cushion profile and roller webbing Profilo cuscino sedile e schienale e cinghe rullo



* 0075R
red
rosso

* 0095B
blue
blu

* 0082N
natural
naturale

Frame and interlacing matching Abbinamento struttura e intreccio

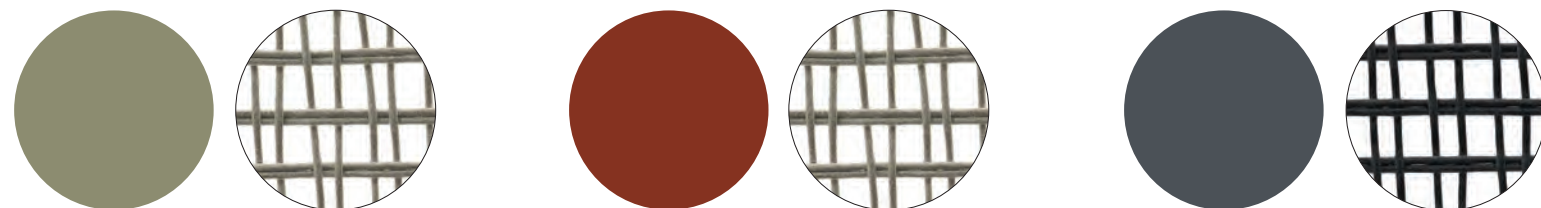

* 0431S
sage frame / natural polypropylene
struttura salvia / polipropilene naturale

* 0721A
clay frame / natural polypropylene
struttura argilla / polipropilene naturale

* 0132N
anthracite frame / anthracite polypropylene
struttura antracite / polipropilene antracite

* Image not in scale / Immagine non in scala

Struttura	pressofusione ed estrusi d'alluminio con verniciatura a polvere poliestere
Imbottitura schienale e rullo	ecogreen (misto polietilene e poliestere), fodera in fibra di poliestere con trattamento idrorepellente
Imbottitura sedile	poliuretano sagomato, ecogreen (misto polietilene e poliestere), fodera in fibra di poliestere con trattamento idrorepellente
Intreccio	treccia in fibra di polipropilene
Doghe seduta	fibra di vetro
Puntali	materiale termoplastico
Telo di copertura impermeabile	tessuto PES monospalmato su un lato PU
Rivestimento	tessuto in categorie limitate (con profilo)

Springtime, Jean-Marie Massaud - 2008

ST266_10AW

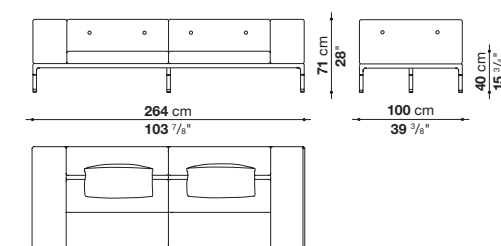

ST266_14AW

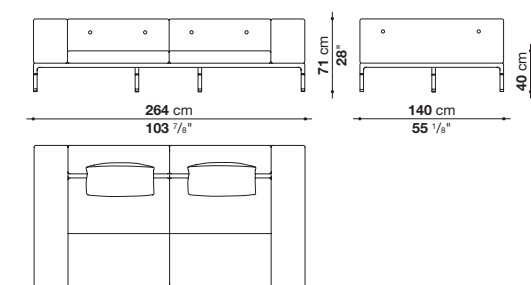

STT

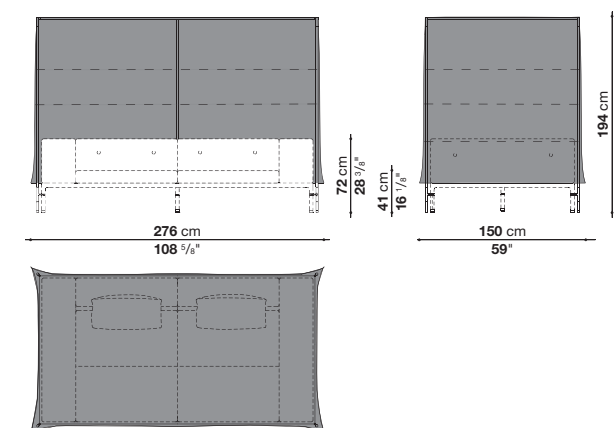

ST100CHAW

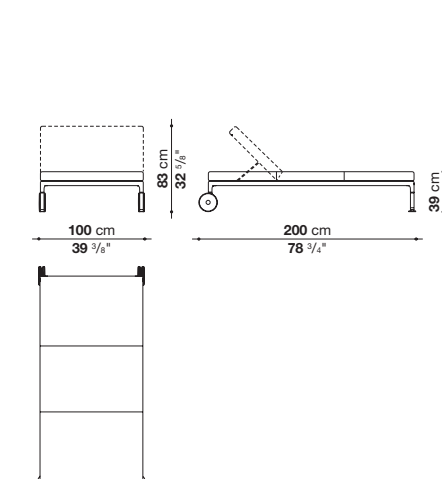

ST170CH_2AW

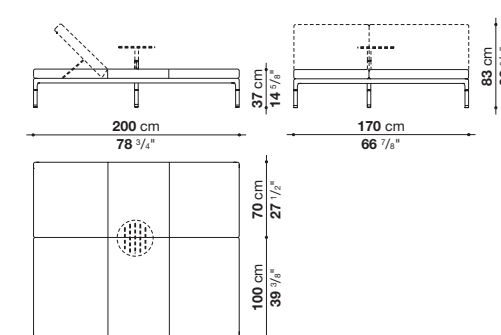

ST170CH_4AW

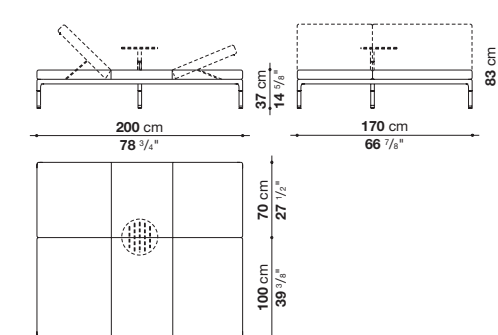

ST

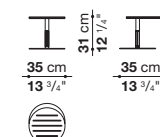

TST200A

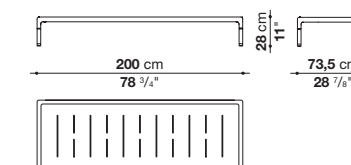

Springtime, Jean-Marie Massaud - 2008

TST4

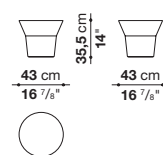

TST7

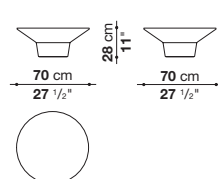

TST11

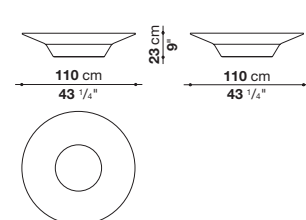

Frame	die-cast aluminium and extrusions with polyester powder painting
Seat top	HPL stratified laminate panel
Sofa back and armrest internal frame	steel and wood
Sofa back and armrest internal frame upholstery	shaped polyurethane, cover in water repellent polyester fibre
Seat cushion	shaped polyurethane of different density, cover in water repellent polyester fibre
Chaise longue headrest cushion and seat cushion (ST100CW)	shaped polyurethane, cover in water repellent polyester fibre
Back cushion	polyester fibre, cover in water repellent polyester fibre
Canopy with drapes (STT)	Alea polyester fabric, aluminium and steel extrusions with polyester powder painting
Chaise longue reclining mechanism	aluminium
Chaise longue wheels	steel and thermoplastic material
Small table and service element top (ST-TST200A)	veneered water-repellent multi-layered wood panel
Frame and top (TST4-TST7-TST11)	Cristalplant Outdoor® (natural mineral filler of phosphate of aluminium with polyester acrylate resin)
Feet	stainless steel
Ferrules	thermoplastic material
Waterproof cover cloth	PES fabric coated on one side in PU
Waterproof cover cloth (ST266_10AW-ST266_14AW)	polyester on synthetic support
Cover	fabric in limited categories

Frame
Struttura

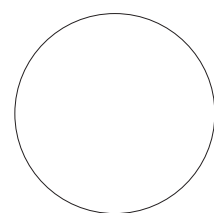

09010
white painted
verniciato bianco

Drape for canopy (STT)
Tenda per baldacchino (STT)

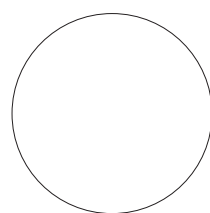

2372100
white Alea fabric
tessuto Alea bianco

Top (ST - TST200A)
Piano (ST - TST200A)



0320M
mahogany
mogano

Frame and top (TST4 - TST7 - TST11)
Struttura e piano (TST4 - TST7 - TST11)

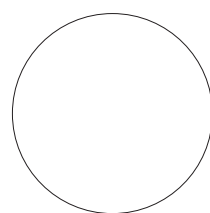

0101G
white Cristalplant Outdoor®
Cristalplant Outdoor® bianco

Struttura	fusione ed estrusi d'alluminio con verniciatura a polvere poliestere
Piano sedile	pannello in laminato stratificato HPL
Telaio interno schienale e bracciolo divano	acciaio e legno
Imbottitura telaio interno schienale e bracciolo divano	poliuretano sagomato, fodera in fibra di poliestere con trattamento idrorepellente
Cuscino sedile	poliuretano sagomato a densità differenziata, fodera in fibra di poliestere con trattamento idrorepellente
Cuscino poggiatesta e cuscino sedile chaise longue (ST100CW)	poliuretano sagomato, fodera in fibra di poliestere con trattamento idrorepellente
Cuscino schienale	fibra di poliestere, fodera in fibra di poliestere con trattamento idrorepellente
Baldacchino con tenda (STT)	tessuto di poliestere Alea, estrusi d'alluminio e acciaio con verniciatura a polvere poliestere
Meccanismo reclinabile chaise longue	alluminio
Ruote chaise longue	acciaio e materiale termoplastico
Piano tavolino ed elemento di servizio (ST-TST200A)	pannello in multistrato di legno idrofugo impiallacciato
Struttura e piano (TST4-TST7-TST11)	Cristalplant Outdoor® (carica minerale naturale di idrato d'alluminio con resina poliestere acrilata)
Piedini	acciaio inossidabile
Puntali	materiale termoplastico
Telo di copertura impermeabile	tessuto PES monospalmato su un lato PU
Telo di copertura impermeabile (ST266_10AW-ST266_14AW)	poliestere su supporto sintetico
Rivestimento	tessuto in categorie limitate

Tabour Outdoor, Nipa Doshi and Jonathan Levien - 2018

TBO1

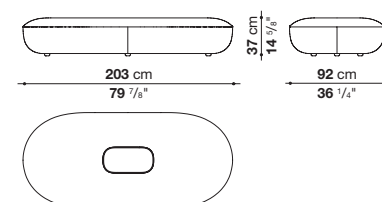

TBO2

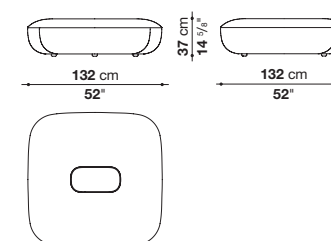

Upholstery	Bayfit® (Bayer®) flexible cold shaped polyurethane foam, expanded polystyrene, water repellent polyester fibre cover (with heat-sealed ribbon)
Bottom base	MDF wood fibre panel
Tray	high density polyurethane resin (Baydur®)
Feet	thermoplastic material
Waterproof cover cloth	PES fabric coated on one side in PU
Cover	fabric in limited categories

Tray
Vassoio

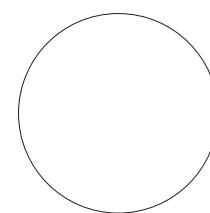

0241W
white painted
verniciato bianco

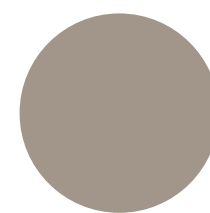

0366T
tortora painted
verniciato tortora

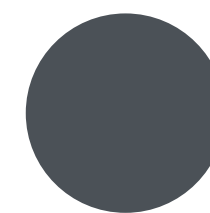

0260A
anthracite painted
verniciato antracite

Imbottitura	schiuma di poliuretano flessibile a freddo Bayfit® (Bayer®), polistirolo espanso, fodera in fibra di poliestere con trattamento idrorepellente (con cuciture termosaldate)
Base	pannello in fibra di legno MDF
Vassoio	resina poliuretana ad alta densità (Baydur®)
Piedini	materiale termoplastico
Telo di copertura impermeabile	tessuto PES monospalmato su un lato PU
Rivestimento	tessuto in categorie limitate

Titikaka, Naoto Fukasawa - 2009

TK

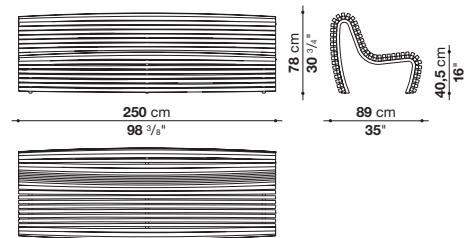

Frame	aluminium and solid wood
Ferrules	plastic material

Struttura	alluminio e legno massello
Puntali	materiale plastico

Frame
Struttura



0440T
natural teakwood
teak naturale

Tobi-Ishi Outdoor, Edward Barber and Jay Osgerby - 2017

OT162

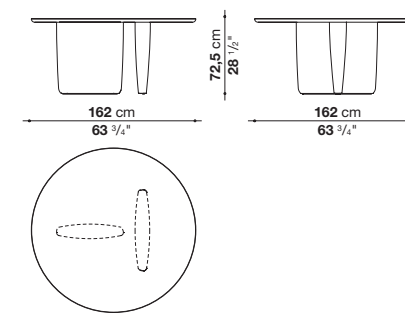

Top and legs	cement (Ultra High Performance Concrete)
Coupling plate	galvanized sheet
Feet	stainless steel
Ferrules	thermoplastic material

Top and legs
Piano e gambe

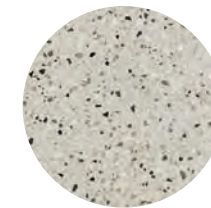

0237G
grey cement
cemento grigio

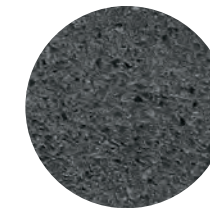

0149A
anthracite cement
cemento antracite

OT146

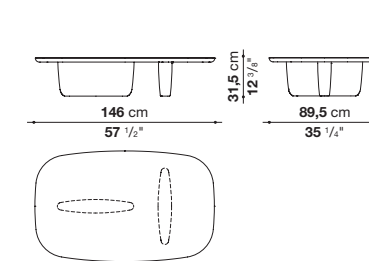

Piano e gambe	cemento (Ultra High Performance Concrete)
Piastra di aggancio	lamiera zincata
Piedini	acciaio inox
Puntali	materiale termoplastico

Twist, B&B Italia CR&S - 2018

TW01

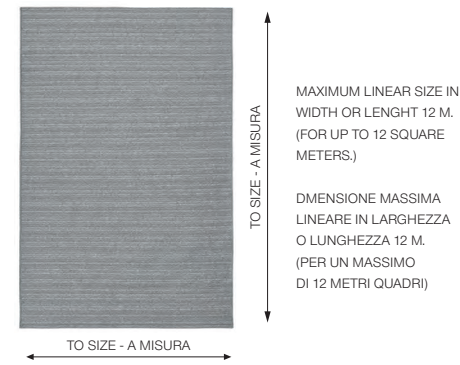

TW200

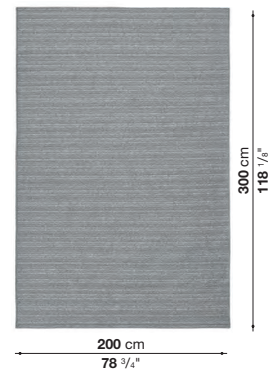

TW250



TW300



Carpet	braided ropes with dyed Olyna FLYER® fibre
Composition	100% polyolefin

Tappeto	corde intrecciate con fibra tinta Olyna FLYER®
Composizione	100% poliolefine

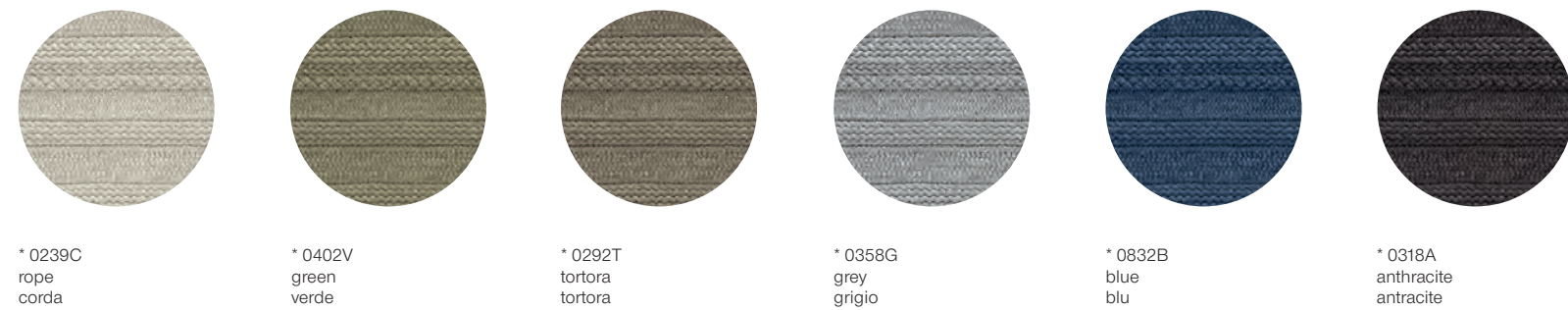

White Collection, Marcel Wanders - 2008

AB20046B

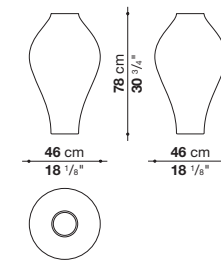

AB20047B

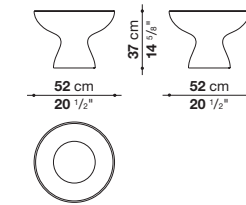

AB20048B

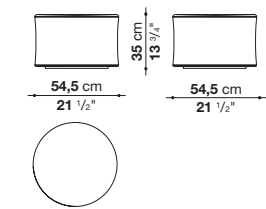

Frame	enamelled ceramic	Struttura	ceramica smaltata
--------------	-------------------	------------------	-------------------

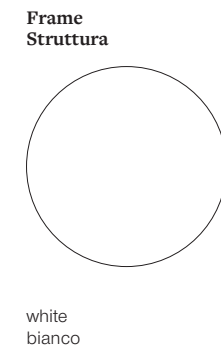

white
bianco

* The colours and materials shades reproduced on paper is an indication, image not in scale
La tonalità dei colori e dei materiali riprodotta su carta ha un valore indicativo, immagine non in scala

Fabrics - Tessuti



Agate 100



Agate 251



Agate 207

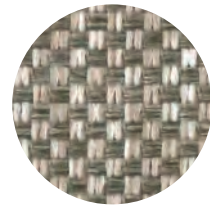

Agate 287

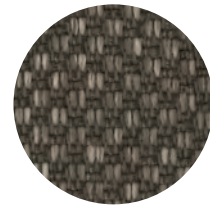

Agate 153



Agate 350

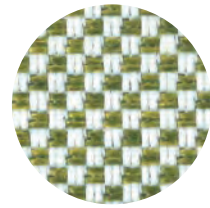

Agate 410

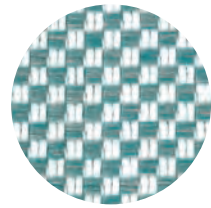

Agate 810

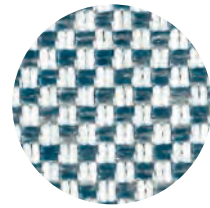

Agate 851

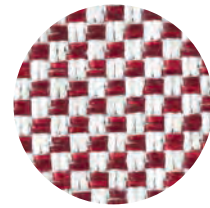

Agate 751

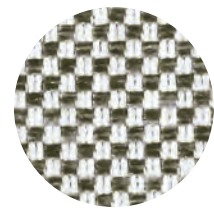

Agate 257

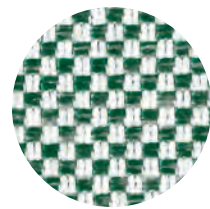

Agate 400

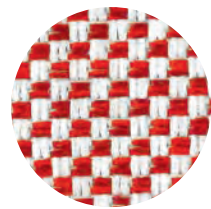

Agate 700

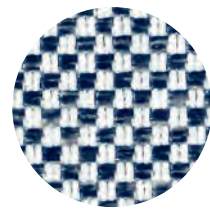

Agate 800



Alceo 100

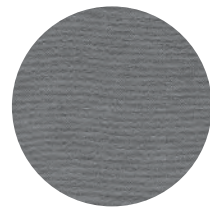

Alceo 255



Alceo 258



Bali 100



* Bali fiorato 100



* Efeso 331

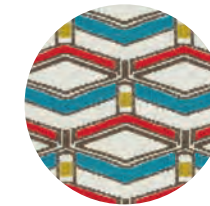

* Efeso 381



* Efeso 111

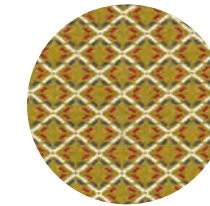

* Efeso 411

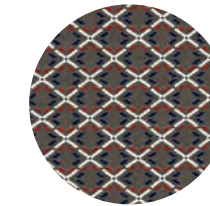

* Efeso 511



* Efeso 811

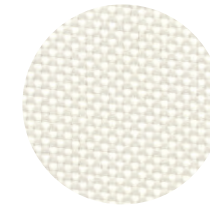

Elce 100

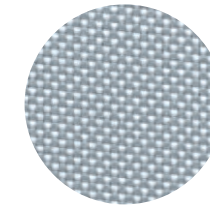

Elce 253

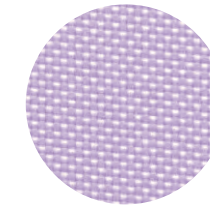

Elce 660

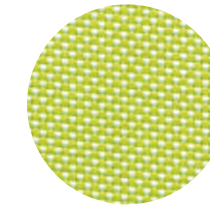

Elce 407



Elide 100

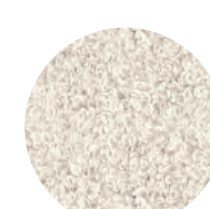

Elide 102

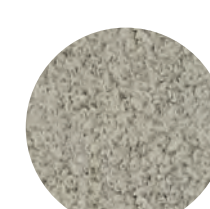

Elide 280

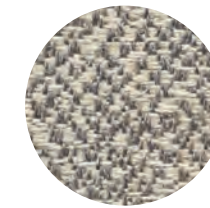

Eos 257

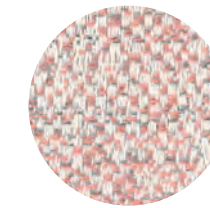

Eos 791

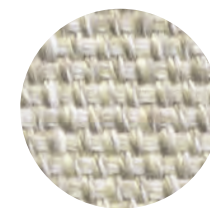

Leila 102

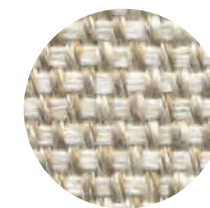

Leila 203

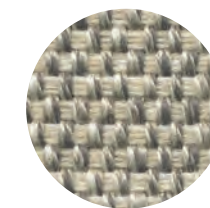

Leila 207

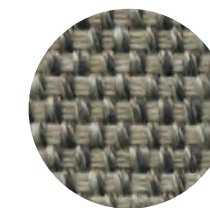

Leila 280

Fabrics - Tessuti



Lesia 101



Lesia 207



Lesia 280



Lesia 251



Lesia 255



Lesia 800



Lesia 877



Lesia 830



Lesia 820

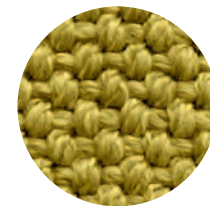

Lesia 403



Lesia 400

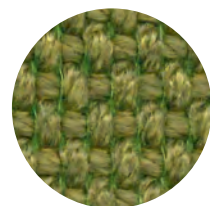

Lesia 407

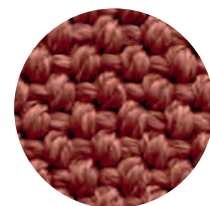

Lesia 305

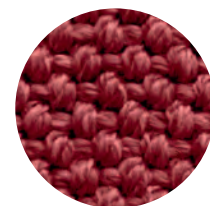

Lesia 750

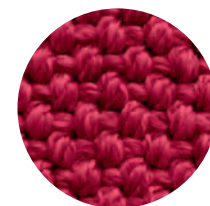

Lesia 700



Lindos 100



Lindos 102

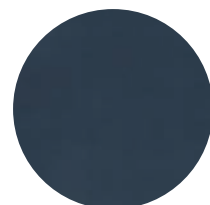

Lindos 800



* Lipari 100

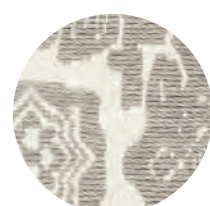

* Lipari 207



* Lipari 911



* Lipari 280



* Lipari 255



* Loreo 100



* Loreo 231

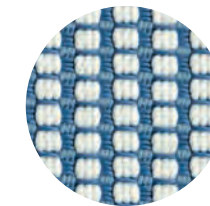

* Loreo 885

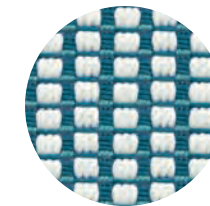

* Loreo 484

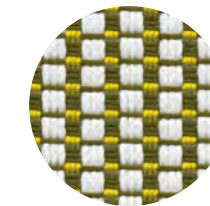

* Loreo 477

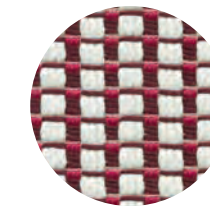

* Loreo 795



* Samos 877



* Samos 450



* Samos 750

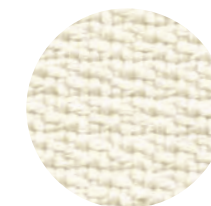

Silea 100

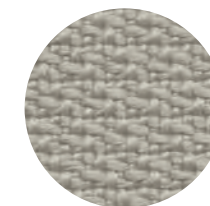

Silea 280

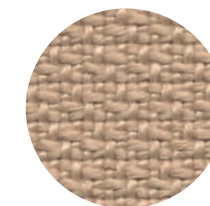

Silea 791

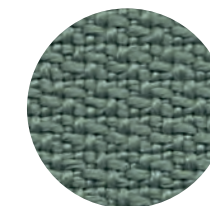

Silea 431

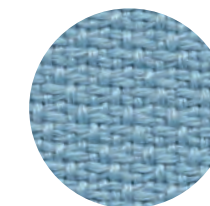

Silea 815

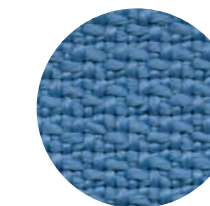

Silea 810

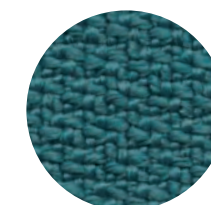

Silea 444

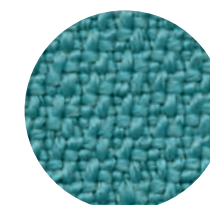

Silea 403

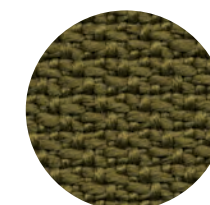

Silea 405

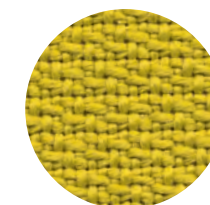

Silea 407



Silea 750

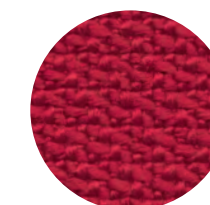

Silea 755

Only for Husk Outdoor - Solo per Husk Outdoor



Eleo 100

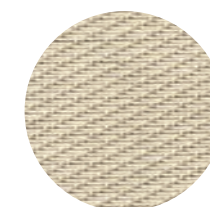

Eleo 200

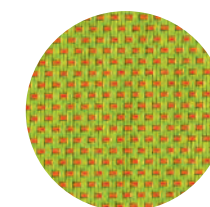

Eleo 450

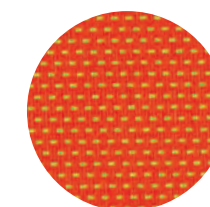

Eleo 570

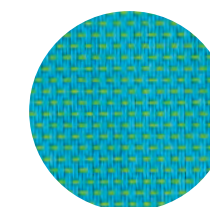

Eleo 810

Fabrics - Tessuti

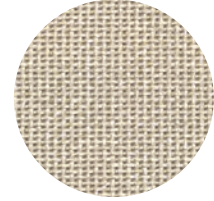

* Elisir 207



* Elisir 110



* Elisir 115

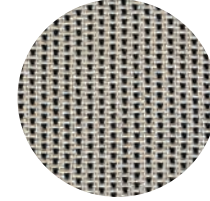

* Elisir 120

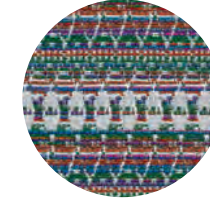

* Salinas 715

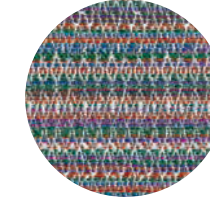

* Salinas 735



* Elisir 810



* Elisir 815

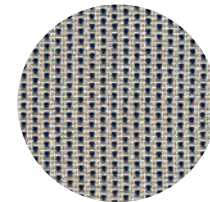

* Elisir 820

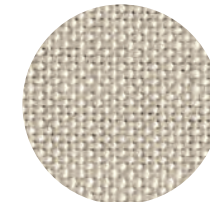

* Scirocco 207

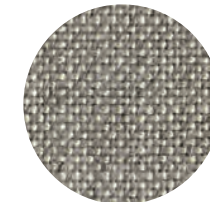

* Scirocco 280

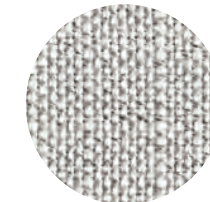

* Scirocco 253

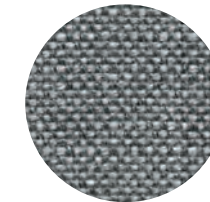

* Scirocco 258

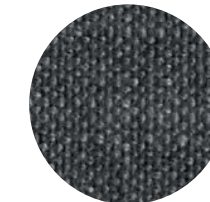

* Scirocco 153



* Elisir 710



* Elisir 715

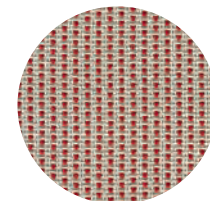

* Elisir 720

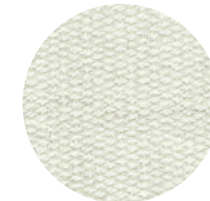

* Ermitage 101

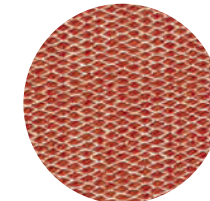

* Ermitage 775

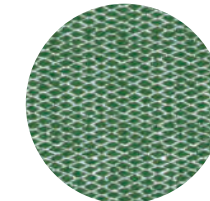

* Ermitage 400

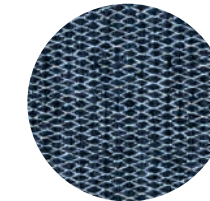

* Ermitage 840



* Elisir 310



* Elisir 315

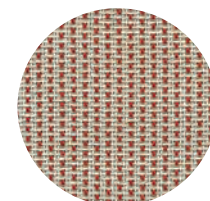

* Elisir 320

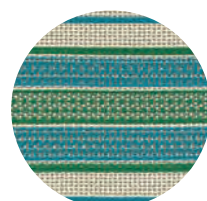

* Elisir 410



* Elisir 415

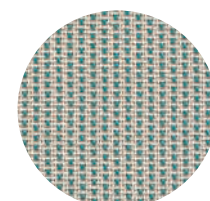

* Elisir 420

Contacts - Contatti

B&B ITALIA SPA
22060 Novedrate (CO) Italy
Strada Provinciale 32
T. + 39 031 795 111
F. + 39 031 791 592
Info: info@bebitalia.com

www.bebitalia.com
www.maxalto.it

Italia
numero verde 800 018 370

USA
toll free number 800 872 1697

All other countries
T. + 39 031 795 213
F. + 39 031 791 592

B&B Italia STORES

Europe

B&B Italia Milano
Via Durini 14, Milano
T. 02 76 44 41
store.milano@bebitalia.it

B&B Italia "Scalo Milano"
Via Milano 5, Locate Triulzi (MI)
T. +39 328 5905162
scalomilano@internionline.it
<http://scalomilano.bebitalia.it>

B&B Italia Genova
Via Macaggi 41 R, 16121 Genova
T. 010 8446734
bebitalia@fedesign.it
<http://genova.bebitalia.it>

B&B Italia London
250 Brompton Road
London SW3 2AS
T. 020 7591 8111
store.london@bebitalia.it

B&B Italia Paris
35, Rue du Bac
75007 Paris
T. 01 55 35 14 35
info@bebitalia.fr

B&B Italia Saint-Tropez
Avenue Maréchal Foch
quartier Saint Roch
83992 Saint-Tropez
T. 0033.494457720
contact@bebsttropez.fr

B&B Italia Lyon
22 Rue Auguste Comte
69002 Lyon
T. 0033 09 86 56 21 53
bebitalia@maisonhomedesign.fr

B&B Italia Berlin
Torstrasse 140
10119 Berlin
T. 0049 30403 691020
info@minimum.de

B&B Italia München
Maximiliansplatz 21
80333 München
T. 089 461 368 - 0
info@bebitalia.de

B&B Italia Wien
Franz-Josefs - Kai 45 - 1010 Wien
T. +43 (0) 1 533 55 00
Info@bebitalia-wien.at

B&B Italia Athens
358 Kifisias Ave 15233
Chalandri Athens
Greece
T. 0030.2106847720
info@deloudis.gr

B&B Italia Cyprus
50 Limassol Avenue
2014 Nicosia
Tel. 00357.22250700
marketing@ergohomegroup.com

B&B Italia Istanbul
Dereboyu Cd. No. 78,
Ortaköy - Istanbul
T. +90 212 327 0595
info@mozaikdesign.com

Americas

B&B Italia New York
150 East 58th Street
New York, NY 10155
T. 212 758 4046
info.usa@bebitalia.com

B&B Italia Madison Avenue
135 Madison Avenue
New York, NY 10016
T. +1 212 889 9606
info.usa@bebitalia.com

B&B Italia Washington DC
3320 M Street Northwest
Washington DC 20007
T. 202 337 7700
info.usa@bebitalia.com

B&B Italia Los Angeles
8801 Beverly Boulevard
Los Angeles, CA 90048
T. 310 278 3191
info@divafurniture.com

B&B Italia Chicago
314 West Superior St.
Chicago, IL 60654
T 312 335 3855
info@wpachicago.com

B&B Italia Miami
2331 Ponce de Leon Boulevard
Coral Gables, FL 33134
T. 305 448 7367
info@luminaire.com

B&B Italia Dallas
1707 Oak Lawn Avenue,
Dallas, TX 75207
T. 214 389 9513
info@bebitalia.com

B&B Italia San Francisco
2211 Alameda Street,
San Francisco, CA 94103
T. 415 565 0900
sales@arksf.com

B&B Italia Seattle
1300 Western Avenue
Seattle, WA 98101
T. 206 287 9992
seattle@divafurniture.com

B&B Italia Sun Valley
350 Walnut Avenue
Ketchum, ID 83340
T. 208 928 6379
rob@arsunvalley.com

B&B Italia Mexico City
Avenida Presidente Masaryk 275,
Esquina con Temistocles,
Colonia Polanco,
Delegación Miguel Hidalgo, C.P. 11560,
Ciudad De Mexico, Local B
T. 0052 5552815551
bebitalia@piso18.com

B&B Italia Sao Paulo
Avenida Brasil 1653 Jardim America
CEP: 01431-001 São Paulo (SP) Brasil
T. +55 11 3368-6033
contato@casualmoveis.com.br

B&B Italia Belo Horizonte
Rua Andaluzita, 125 Carmo Sion
Belo Horizonte (MG)
T. +55 31 3281 4882
contato@casualmoveis.com.br

Asia

B&B Italia Tokyo
1, 3F Aoyama OM- Square 2-5-8,
Kita Aoyama,
Minato-ku, Tokyo 107-0061
T. 03 3478 3837
info@bebitalia.co.jp

B&B Italia Beijing
1st floor, International Hall 5,
Easyhome at North
4th Ring Road, Beijing, China
T. 0086 10 84648161
beb@designspace.com.cn

B&B Italia Shanghai
Unit L1-W10, No. 168 Hubin Rd.,
Huangpu District, Shanghai 200021
T. 0086 021 63300606
info@arealiving.cn

B&B Italia Nanjing
No. 168, Jiangdongzhong Road,
Jianye District, Nanjing, Jiangsu
T. 025 6819 7311
info@yonglong-furniture.com

B&B Italia Chengdu
Unit 1071-1072, 1st floor,
No. 3 Fusen Mall,
No.18 Shenghe 2nd Road,
Gaixin District, Chengdu, Sichuan
T. 177 8069 8361
bb@tinyhome.cn

B&B Italia Shenzhen
No.109-209A North Zone,
One Shenzhen Bay Plaza,
Nanshan District,
Shenzhen, Guangdong
T. 400 823 8099
info@wanbinspace.com

B&B Italia Foshan
5th Floor, Louvre mall,
Lecong Section
of National Highway No. 325
Shunde, Foshan, Guangdong
T. 400 188 1222
louvre@louvre-furniture.com

B&B Italia Wenzhou
King Loche 101 A, Kaiyuan Road,
Zhejiang Province 325000 Wenzhou City
T. 0086.577.88660166
info@casanuova.com.cn

B&B Italia Hong Kong
31st floor, China Online Center
333 Lockhart Road, Wanchai
Hong Kong
T. +852 2295 3612
bebitalia@colourliving.com

B&B Italia Kaohsiung
67, Minquan 1st Rd.,
Kaohsiung, Taiwan 80251
T. +886 7 332 7676
service@bonmaison.co

B&B Italia Taipei
2F, No.95, Sec. 2, Dun-Hua S. Road,
Daan District 10682 Taipei
Taiwan - China
T. 00886 227555855
service@bonmaison.co

B&B Italia Taichung
211, Chaofu Rd.,
Taichung, Taiwan 40757
T. +886 4 2258 5632
service@bonmaison.co

B&B Italia Seoul
6-15 Chungdam-dong
Gangnam-gu, Seoul
T. + 82 2 3447 6000
infirni@infirni.co.kr

B&B Italia Busan
454, Jwadong Sunhwan-Ro,
Haeundae-Gu, Busan,
T. +82 (0)51 731 3470
infirni@infirni.co.kr

B&B Italia Bangkok
523 Mahaprutharam Road
10500 Bangkok, Thailand
T. +66 2 237 6999
badipol.ch@yipjacks.com

B&B Italia Ho Chi Minh City
1st Floor Times Square Building
22-36 Nguyen Hue Boulevard & 57-69F
Dong Khoi Street, Ben Nghe Ward,
District 1, Ho Chi Minh City, Vietnam
T. 0084-8 66 840 333
bebitalia@eurasia-concept.com

B&B Italia Manila
Twenty-four Seven McKinley
Corner of Seventh Avenue,
24th Street & McKinley Parkway,
Bonifacio Global City Philippines
T. +63 2 634 85 87
corporate@focusglobalinc.com

B&B Italia Jakarta
Jl. Kemang Raya No. 17
Jakarta 12730 Indonesia
T. +62 21 7180349
bebitalia@magran.co.id

B&B Italia New Delhi
DLF Chattarpur Farms 2, North Drive
110074 Chattarpur, New Delhi
T. +91 999 969 3093
bebitalia@latendenza.com

Middle East / Africa

B&B Italia Dubai
Jumeirah Beach Road - Jumeirah 3
next to Dubai offshore Sailing Club
Dubai UAE - T. 971 43466932
baituti@baituti.com

B&b Italia Beirut
An Nahar Building,
Martyrs Square, Downtown
T. +961 1971444
bebitalia@cercler.me

B&B Italia Tel Aviv
3 Hatarucha Street
63509, Tel Aviv, Israel
T. 972 3 7449935
studio3@bebitalia.co.il

B&B Italia Accra
No. 6,7, 9 Liberation Road
Accra, Ghana
T. 00233 302 79 1393
bebitalia@forbghana.com

Maxalto STORES

Maxalto is a B&B Italia brand.
For additional information
on the Maxalto collection please visit
our Maxalto or B&B Italia Stores.

Maxalto è un marchio B&B Italia.
Per conoscere la collezione Maxalto visiti
gli Store Maxalto o B&B Italia.

Americas

Maxalto Los Angeles
8900 Beverly Blvd.
Siute 106 - West-Hollywood
Los Angeles, CA 90048
T. 310 986 6448
info@divafurniture.com

Maxalto Miami
30 NE 39th St, Miami, FL 33137
T. 305-572-2900
info@maxaltomiami.com

Credits - Crediti

Graphic design

Juma

StylingPatrizia Cantarella
pc studio
Monica Montemartini
Simona Silenzi Studio**Photography**Tommaso Sartori
Fabrizio Bergamo
Salva Lopez**Copyright**CR&S B&B Italia
March 2019**Printing**

Grafiche Antiga

Thanks toAs'art, Ay Illuminate,
concrete sculpture by Marco Olgio
Danese, Flos, Giacomelli giardini,
Ilaria Bianchi, Industreal, Kommod
Luca Leandri – Galleria Amuralab
Oluce, Pallodi, Pinetti, Pulpo,
Scandola Marmi, Sfera.

Descriptions and pictures of products included in this catalogue have an indicative value only and are not binding for products' use. B&B Italia reserves the right to modify their products without prior notification. For further technical information of the products, please contact the authorised dealer closest to you (see www.bebitalia.com).

La descrizione e le immagini dei prodotti del presente catalogo sono puramente indicative e non possono essere considerate vincolati ai fini del loro utilizzo. B&B Italia si riserva di apportare ai prodotti le modifiche che ritiene più opportune, in qualsiasi momento e senza preavviso. Per ulteriori informazioni sulle caratteristiche tecniche dei prodotti, invitiamo a consultare il sito www.bebitalia.com dove troverete l'elenco dei rivenditori autorizzati a cui rivolgerci.