

A photograph of a modern building facade at dusk. The building features a light-colored, textured facade with large windows. The interior lights are on, and the sky is a deep blue. A paved walkway with a low wall and lights runs along the building. In the background, another building with a glass facade is visible.

#26

SWISSPEARL ARCHITECTURE

**SWISS
pearl®**

#26

SWISSPEARL ARCHITECTURE

- Building of the Year
- 2 **O'REILLY CLINICAL HEALTH SCIENCES CENTER, USA**
Cannon Design
- 17 **FOREWORD**
by Marco Steg, CEO
- 18 **ESSAY**
Mapping the Effects of Globalization on Contemporary Architecture, by Anna Roos
- 22 **DESIGN**
Seater from the Concrete Garden Collection
- 24 **MAKING OF**
Cinema Complex in the Mall of Switzerland
- 30 **EMPLOYEE PORTRAIT**
Dominik Baumgartner, Polymechanic
- 37 **FOCUS 1: ARHIV GRADA, SERBIA**
- 38 **STUDENT RESTAURANT, CROATIA**
Sangrad and AVP
- 42 **MALL OF AMERICA PHASE EXPANSION AND JW MARRIOTT HOTEL, USA**
DLR Group
- 48 **NEPTUNE OFFICE BUILDING, USA**
Polk Stanley Wilcox
- 52 **FOCUS 2: MAXIMA HQ, LITHUANIA**
- 53 **FOCUS 3: MC KINNEY HIGH SCHOOL, USA**
- 54 **VILLA MARTINUZZI, CROATIA**
Tobis Engineering
- 60 **OSPEDALE DEL MARE, ITALY**
IaN+
- 68 **SEAMUS HEANEY HOME PLACE, NORTHERN IRELAND**
W M Given
- 72 **FOCUS 4: OFFICE BUILDING, HUNGARY**
- 73 **FOCUS 5: INTERNATIONAL SCHOOL, CANADA**
- 74 **AIR TRANSPORT BUILDING, SLOVAKIA**
Tomáš Sobota
- 80 **B66 BUSINESS CENTER, LITHUANIA**
Vytautas Janušaitis
- 84 **N2 HOUSE, ISRAEL**
Irene Goldberg and Pitsou Kedem
- 90 **FOCUS 6: SAP LOBBY, HUNGARY**
- 91 **FOCUS 7: WORKS YARD, SWITZERLAND**



CANNON DESIGN, CHICAGO

Both Compact and Light

O'Reilly Clinical Health Sciences Center,
Springfield, Missouri, USA

The new building for the College of Health and Human Studies at Missouri State University impresses through its sculptural formation. That can be said not only of the volume, but also the spatial organization, which includes a communication zone connecting all floors.

Text by Hubertus Adam





O'REILLY CLINICAL HEALTH SCIENCES CENTER

Springfield, located in southwestern Missouri, is the U.S. state's third largest city with a good 150,000 residents. Not only a regional administrative center, Springfield is also an important college town. Top dog is Missouri State University, with an enrollment of 20,000 students. The second largest university in the state emerged from an institution founded for teacher training in 1905, and changed its name several times as it grew, until it was given its current name in 1985. The campus is located in the eastern part of the downtown area, thus in the center of town, and fits into the orthogonal grid of the street front running east to west, and also north to south.

The O'Reilly Clinical Health Sciences Center, which opened in 2015, is located at the intersection of East Cherry Street and South Holland Avenue and is the most recent building block of the College of Health and Human Studies. Further west, East Cherry Street is flanked by the Nursing Building on the north and a building for Physical Therapy on the south. The idea was to integrate the Health & Science Center within this context. The responsible architects from the firm Cannon Design, which is represented at fifteen locations in the U.S. and worldwide, achieved this by interpreting the area between the buildings on East Walnut Street as an open space, which forms, as it were, a miniature campus within the campus. This public space continues with the lobby situated behind the main entrance on the northwestern corner of the new building. Here, the volume is cut and glazed in a welcoming gesture.

Although the inner organization is orthogonal, thereby transferring the logic of the street grid onto the building, one of the architect's goals for their new university building was to break open the rigid geometry. This is evident not only in the slants and upturns of the entry front, but also in the nooks in the southwest, which mediate to the neighboring residential development; the slightly buckled east façade towards South Holland Avenue; and finally, the folds of the roof. What thus arises is a sculpturally-formed volume whose physicality is emphasized by the all-over cladding

with Swisspearl panels in the Carat model, based on the Sigma 8 fixation system. In interplay with the slightly recessed glazing, the horizontally offset panels underscore the building's compactness, but as a recognizably thin façade skin, likewise empathize its lightness. In this way, the new building creates a counterpoint to the rather heavy seeming limestone structures from the post-World War II decades. However, with the Onyx 7090 color option, it purposely integrates into the existing spectrum of colors.

The three stories of the building are accessed by a cascade-like stairway structure, which runs longitudinally, cataract-like through the volume. Rather than limiting itself to actual development, it spreads out on every floor to form its own spatial areas: the lobby on the ground floor, a central area on the second floor, and a student lounge and open terrace cut out from the roof on the third floor. Pub furniture, seating groups, and informal study and

common areas guarantee a maximum amount of communication, while the ceilings' folded wood cladding transfers the plasticity of the outer form to the interior.

The variously dimensioned spaces are reserved largely for the instruction and training in the undergraduate and graduate curricula. Educated are primarily specialists

in the areas of nursing and occupational therapy, but also anesthetic assistants and medical assistants. Required for this are various labs, offices, and preparation rooms, as well as specific areas where clinical situations can be simulated. An auditorium is located next to the lobby on the ground floor. Situated in the southern half of the ground floor is a public clinic, which is the only area that deviates from the otherwise purely academically used premises. The clinic is available for area residents, and also offers an opportunity for students to try out, in practice, the theoretical knowledge that they have gained. The university, located, as it is in the center of Springfield, should benefit the city: Certainly also one of the reasons that Cannon Design realized their building as an iconic structure rather than as a neutral volume.

**“The university,
located as it is in
the center of
Springfield, should
benefit the city.”**

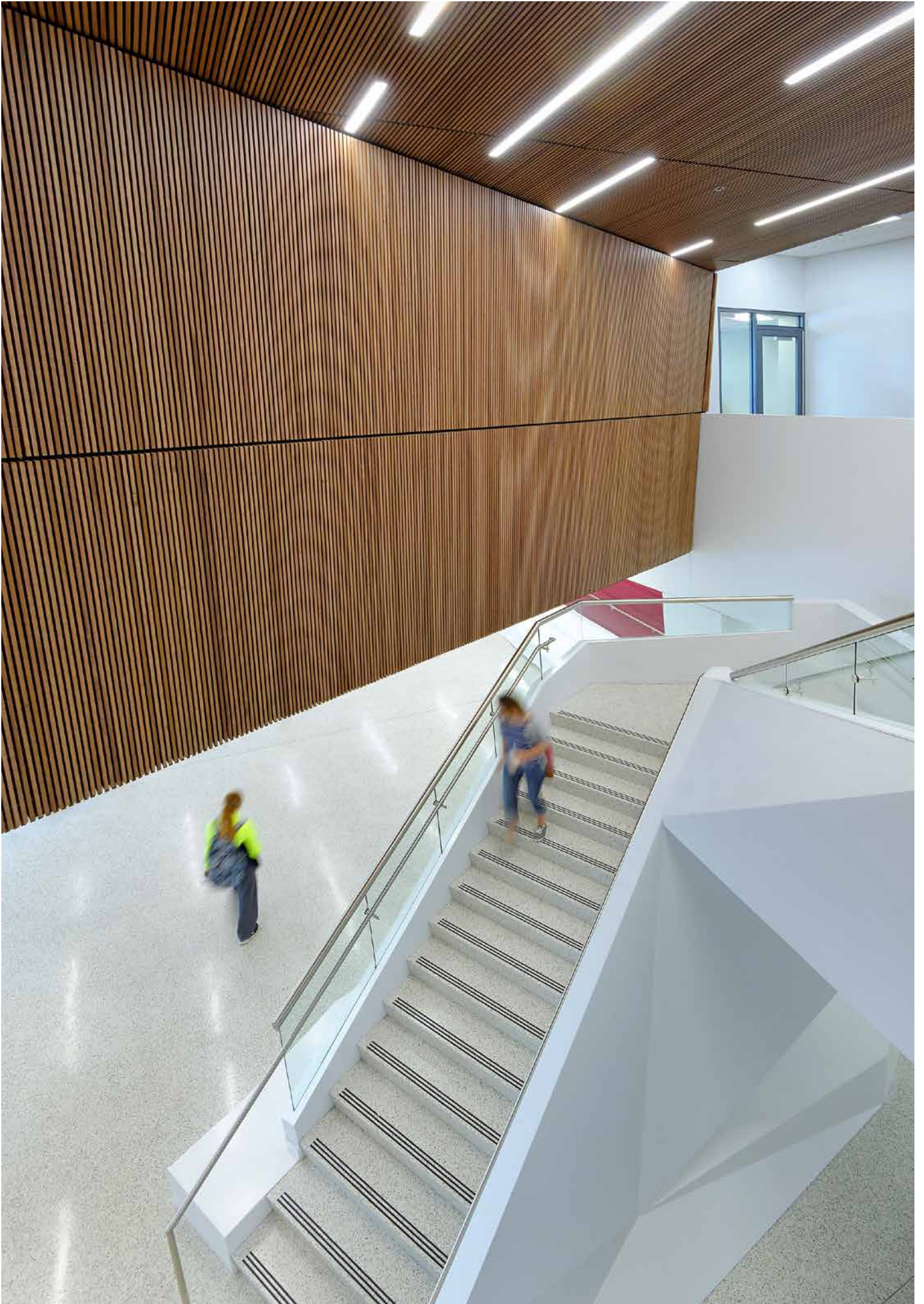

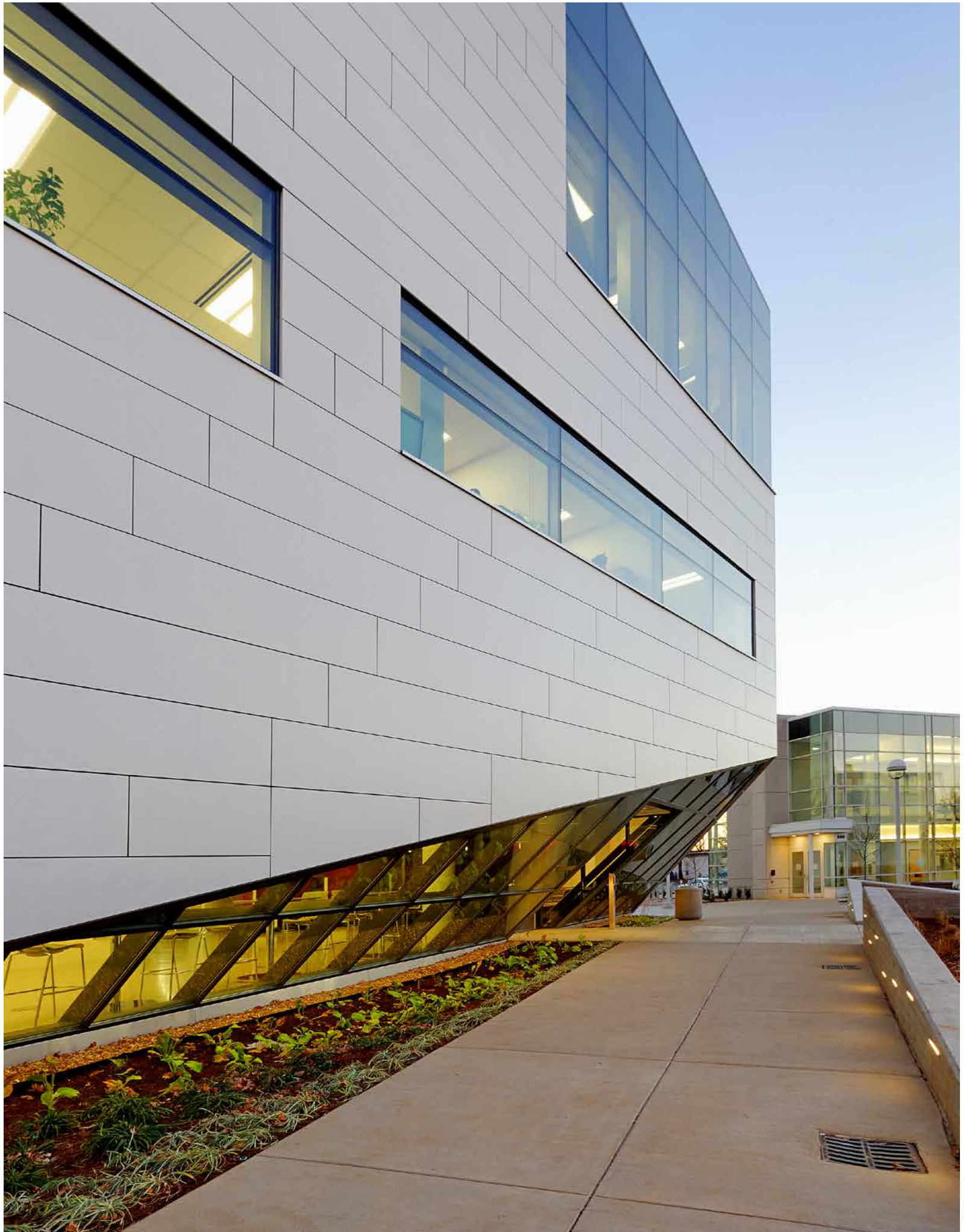

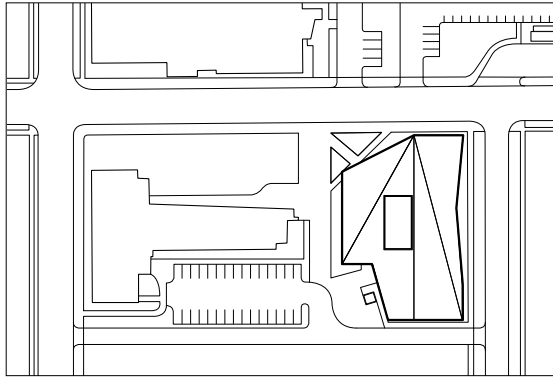

The volume is carefully sculpted by carving away the corner junction, pulling the volume off the perpendicular in plan and elevation and punching a light-well into the center of the volume to allow light and ventilation into the central spaces.

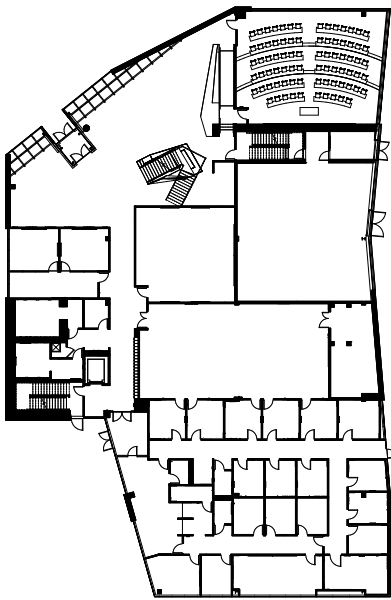

FIRST FLOOR 1:750

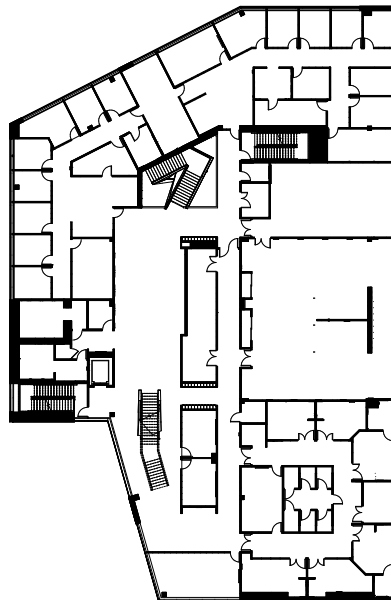

SECOND FLOOR

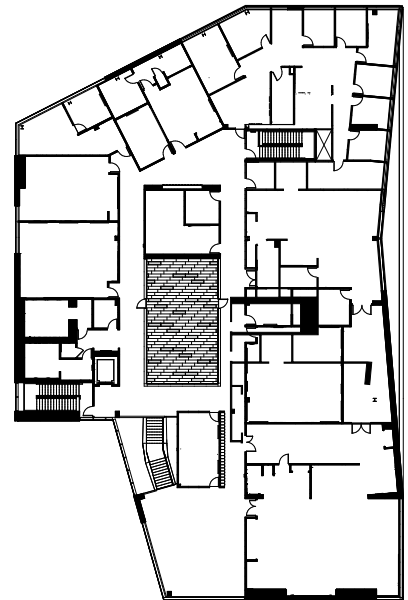

THIRD FLOOR

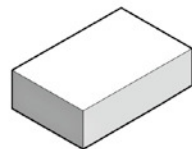

Site Extents

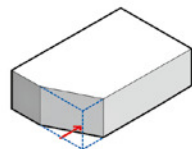

Campus Plaza

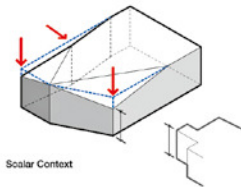

Solar Context

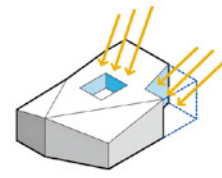

Natural Light

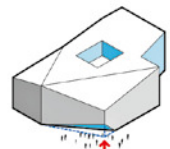

Entry

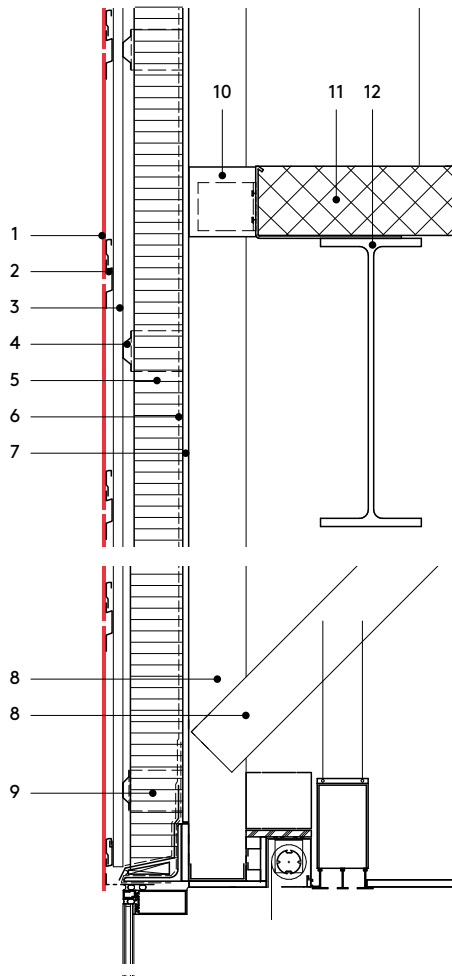

VERTICAL SECTION 1:20

- 1 Swisspearl, 8 mm, invisible attachment
- 2 Sigma 8 panel support profile
- 3 ventilation cavity, vertical aluminum sub framing
- 4 aluminum sub framing
- 5 thermal insulation
- 6 vapor retarder
- 7 gypsum board
- 8 structural steel
- 9 fiberglass bracket
- 10 steel clip
- 11 concrete
- 12 steel beam

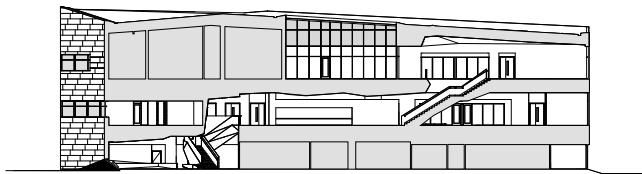

ADDRESS: 640 E Cherry Street, Springfield, Missouri, USA
 CLIENT: Missouri State University, Springfield
 ARCHITECTS: Cannon Design, Chicago; David Polzin
 BUILDING PERIOD: 2014–2015
 GENERAL CONTRACTOR: DeWitt & Associates, Springfield
 FAÇADE CONTRACTOR: Loveall, Springfield
 MATERIAL: Swisspearl Carat, Onyx 7090



A staircase unfolds, like a piece of folded origami. The theme of folded, inclined planes is continued in the freestanding staircase.

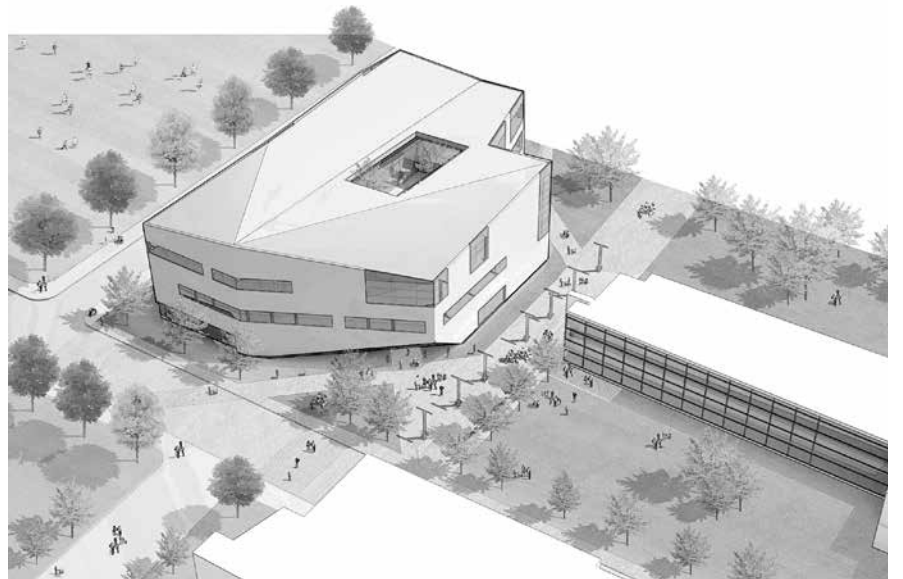

The theme of incision is continued in the façade surfaces. Smooth planes of fiber cement panels are interrupted by vertical and horizontal strips of cut-out glazing.



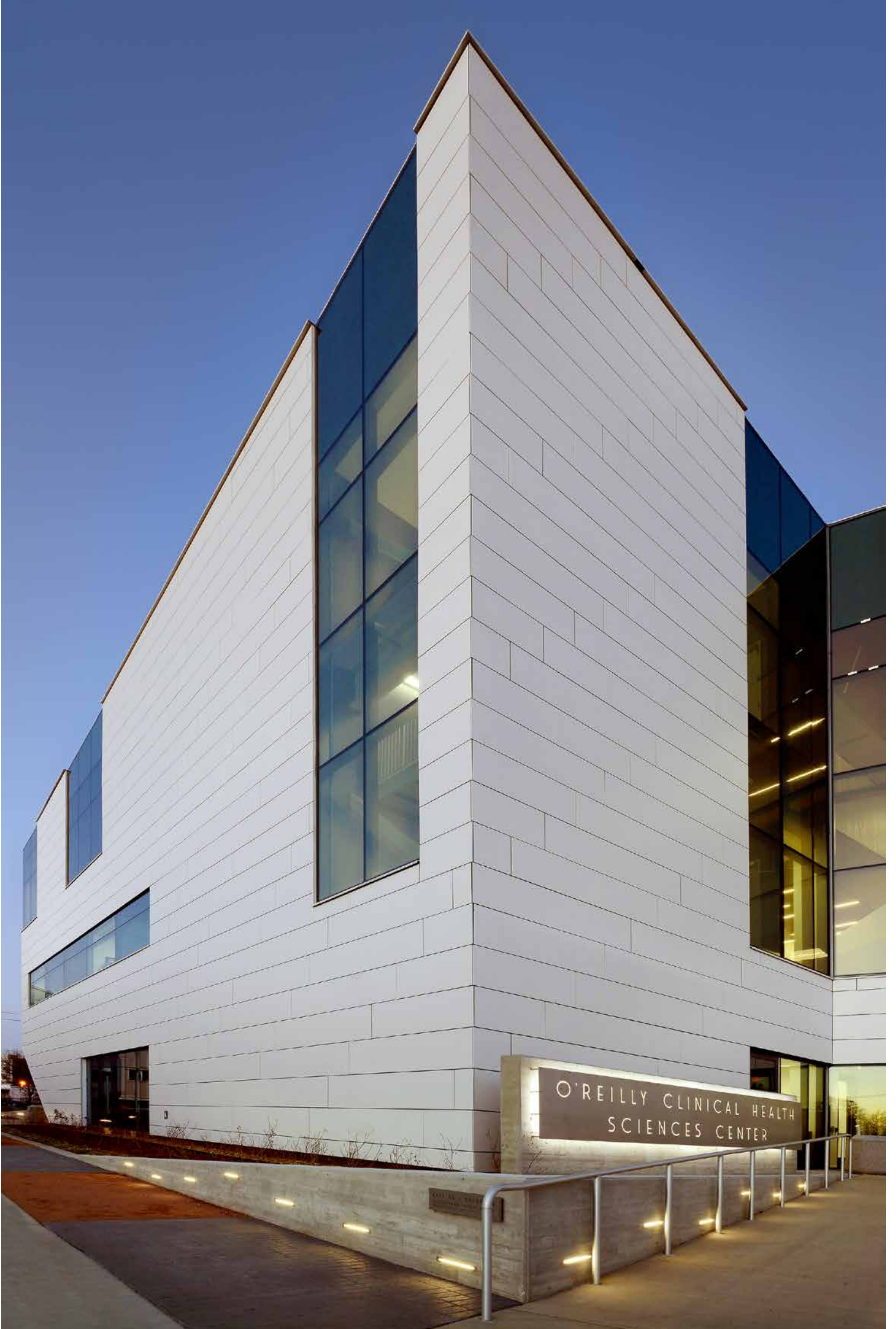

O'REILLY CLINICAL HEALTH
SCIENCES CENTER

INTERVIEW

Cannon Design

Will Cannon Sr. began his career as a one-man architectural firm in Niagara Falls in the state of New York. His firm grew and was able to realize the neoclassicist City Hall in his hometown in 1923/24. His sons Will Jr. and Don joined the firm in 1945, which is considered the official founding date of Cannon Design. The development of new market segments in architecture and engineering and a strategic acquisition of commissions enabled the firm, located in western New York state, to successively expand its radius of action over the following decades—first, across the entire United States, and ultimately throughout the world. In the 1990s, the model of a single firm with many offices was instated; today, Cannon Design comprises sixteen offices; twelve are in the U.S., and one each in Toronto, Montreal, Abu Dhabi, and Mumbai. Cannon Design employs a staff of roughly 1,000. The O'Reilly Clinical Health Center was designed by David M. Polzin from the branch office in St. Louis, Missouri. After working for the firm for eighteen years, Polzin was called to the company management of Cannon Design in autumn of 2016, and now works as head designer. In the following he talks about his work for Cannon Design.



Mr. Polzin, how would you describe the mission of Cannon Design?

We are a globally integrated design firm that unites a dynamic team of architects, engineers, industry experts, and builders driven by a single goal—to help with our clients' and society's greatest challenges.

What does design mean to you?

For me, the creation of every architectural solution is a unique experience of collaboration and exploration. My design process catalyzes the intangible ideas embedded in the aspirations, vision, and identity of a client's organizations and transforms them into tangible built expression. Each solution is the result of the contributions of those people that come together to dream of a building with a soul.

Society and technology are in a state of constant change. How can architecture react to that?

You need to design for flexibility. You need to design buildings that

are not so carefully proscribed to individual needs, so that they can't be anything else in the future. It acutely resonates with our healthcare clients. There are constantly new technologies emerging in the healthcare realm. You don't design a room around a piece of equipment that will be superseded in five years!

You are working on several projects in the area of healthcare. How do you see the balance between technological demands and human needs?

It's posing a greater challenge for architects—how do you design for the human experience, how do you not let technology take over? How do we design to bring communities together, to look away from their devices? Maybe that's the bigger challenge. I'm not trying to put forward a philosophy of being a Luddite.

How do you understand your new role as Executive Director of Design?

Coming from the St. Louis office of Cannon Design, we have a uniquely creative culture. We have a real intensity of purpose and a drive for creative exploration, and I think we also have a great sense of mutual respect for each other. My expectation as I move into a broader role in the firm—sixteen offices, more than 900 people—is not to duplicate that culture, that's not possible, but to try to put into place the right ingredients to stimulate creativity.

The interview was carried out by Hubertus Adam.



Four hundred students from 75 different majors live in the University of Utah's Lassonde Studios. The building, which opened in August 2016, is not only a dormitory, but also houses the 20,000-square-foot (2000-square-meter) "garage," which includes co-working spaces and galleries along with a coffee shop and shared kitchen. With its combination of residential and working spaces, Lassonde Studios offer space for student start-ups in the context of "entrepreneurial education."



San Diego Jacobs Medical Center in La Jolla, California was inaugurated in 2016. The curvilinear forms of the ten-story hospital structure are derived from the design of the patients' rooms, in which the goal was to optimize views and incidence of light.

For the headquarters of the CJ Corporation in Seoul, South Korea, inaugurated in 2015, Cannon Design chose an organically flowing formal language. Three high rises surround a central atrium where public functions are concentrated.





FOREWORD



In your hands is the new edition of *Swisspearl Architecture Magazine*! This publication, which we have enhanced for you in terms of content and design, allows us to show you what creative minds throughout the world accomplish with Swisspearl products.

One successful story is the new lobby of the Ospedale del Mare in Naples, Italy. Its round form and dynamic shell, which seems to surround the building like waves, enable a direct experience of this hospital's name and maritime location.

With its façade of rough natural stone and the velvety, sand-colored fiber cement panels, Villa Martinuzzi in Pula, Croatia impressively combines the rural nature of the site with the high demand for modern living.

In Northern Ireland's Bellaghy, the Seamus Heaney Home Place has created a center for literature and inspiration that honors the life and work of the Irish writer and Nobel prize winner Seamus Justin Heaney (1939–2013). The small structure makes a mark with its eye-catching façade and in the truest sense, speaks volumes!

We also offer a look at our hand molding plant, where a unique shell in the form of a theater curtain was created for the cinema complex of the Mall of Switzerland in Ebikon (Switzerland). Since fiber cement can be freely formed and processed in diverse ways during its manufacture, we are able to cater to our client's personal wishes. Together with designers and material experts, we develop future oriented, functional and also aesthetically pleasing solutions. At the same time, we are also constantly driven by our own high demands in terms of quality.

For more than 120 years, we have created innovative and sustainable products from natural raw materials for use in the high-quality design of buildings and exteriors. High-grade fiber cement was invented in our halls, where it has also been further developed. We are proud of our leading position in the innovation and technology of this material, which is used for roofs and façades, but also in the areas of garden design and interior furnishings.

Have we piqued your curiosity? The *Swisspearl Architecture Magazine* is published periodically and is meant to serve as inspiration. In it, we show extremely diverse buildings and design objects, which all share one thing in common: our products' contribution to their sound architecture and design. Let yourself be surprised!

Marco Steg, CEO Swisspearl

Mapping the Effects of Globalization on Contemporary Architecture

Globalization is referred to mainly in conjunction with economics, politics, and immigration. But what is its impact on the production of architecture? How have the flow of ideas and images and new technological advancements affected architecture in recent decades?

As with fashion and food, contemporary architecture has fallen prey to the influence of globalization. High street in London features the same ubiquitous shopping chains and products as Main street in Sydney or Zurich. Contemporary buildings in cities across the globe closely resemble one another and are frequently designed by international architectural offices located on the other side of the world. Architects are influenced by the architecture they see in journals, and, as with music trends, design trends are no longer specific to a locality. It takes a mere split second to access content on the internet making the universe of images and ideas available to nearly all of us, nearly all of the time.

The nineteen projects presented in this issue of *Swisspearl Architecture Magazine* can be seen as loosely representa-

tive of the current globalized international architectural scene, which features a fluid cross-referencing of forms and an eclectic, architectural border crossing trans-continental language. As holds true for many contemporary buildings, it is difficult to determine where the projects featured in this issue are situated solely by looking at their architectural expression. Global architecture is inextricably linked to global markets, neoliberal economies, and multinational companies; and these forces influence the production of architecture. Over the past few decades many of the norms of the architectural profession have been cast away, thus creating a culture of “anything goes.” As Rem Koolhaas, the doyen of the international architectural

discourse, wrote in his seminal book, *Delirious New York*, there is an “Uncontrollable process of association where everything is connected with everything else.” Although he was referring to twentieth-century, avant-garde architecture, I would suggest this process is still in place today.

GLOBALIZED LANGUAGE

This present magazine features buildings representing a wide variety of typologies and scales, built in an expansive geographic range, from an airport building in Slovakia, to a high school in the United States, a hospital building in Italy to a villa in Israel, to name just a few. In addition to their use of Swisspearl fiber cement cladding, all these disparate buildings likewise share their lack of specificity to a place and the cross pollination of forms. During the 1990s,



Casa da Musica, Lisbon, OMA, 1999–2005. As with the Missouri State University Building, the volume of OMA's Casa da Musica is an amorphous, carved volume.

Monte Rosa Hut, Zermatt, Bearth & Deplazes, 2008–2009. Monte Rosa Hut is another apt example of inclined planes and crystalline architectural forms.





Tate Modern, Switch House,
London, Herzog & de Meuron,
2010–2016. Herzog & de Meuron
take the use of inclined forms
one step further with the
complex torsion of their recent
Tate Modern extension.

architects began moving away from the ironic reinterpretation of historic forms of postmodernist architecture towards a more reduced set of simple, orthogonal forms stacked or arranged in ensembles. This approach remains popular today and many architects still favor flat roofs, orthogonal, abstract forms, and asymmetry. The B66 office building in Kaunas, Lithuania, featured here, is a pertinent example, with its arrangement of horizontal and vertical volumes with overlapping black Swisspearl panels. N2 House in Israel, with its delicate lattice-work and sleek lines, also typifies an enduring preference for abstract, orthogonal forms.

In recent years, straight lines and smooth surfaces have been rejected by many architects in favor of non-parallel, jagged lines and more complex shapes and surfaces; the type of forms that Robert Venturi might refer to as “impure.” Architects are interested in exploring architecture’s expressive nature. Rather than having clean strips of fenestration cut into the façade, the openings of the airport building in Bratislava are sinuous, wavy lines that wrap their way around the four-story structure as though moving visibly around the building. Another pertinent example of the loosening up of forms is the façade of the low-slung, curved hospital reception building in Napoli, which is an interwoven basket of elongated Swisspearl panels and glazing in shades of greens and azure blue. As the façade curves around to meet the sun, the panels catch and reflect the light like the scales of a fish. These projects are good examples of the ways that architects use material and

form expressively, thus lending it more character and personality. Venturi’s maxim, “less is a bore,” interpreted in three dimensions.

COMPUTER AIDED DESIGN

As computer-aided design becomes increasingly more sophisticated, strict orthogonal forms give way to freer expressions. A shift has occurred, away from the “Swiss box” minimalist kind of architecture that architects were beginning to tire of, in favor of impossible-to-build crystalline forms, such as Rem Koolhaas/OMA’s famed Casa da Musica in Porto, which opened in 2005. The Mis-

**“In recent years,
straight lines
and smooth surfaces
have been rejected
by many architects in
favor of more
complex shapes.”**

souri State University building prominently featured here is strongly related to OMA’s Porto project in form and fenestration. With its cut away, chamfered corners, it is a fine example of how architects strayed from the right angle and began embracing skewered shapes in both plan and section. Other well-known buildings in this genre include Monte Rosa hut in the Swiss Alps by Bearth & Deplazes and the extension of the History Museum in Bern by:mlzd.

The torsion of form and rejection of right angles in plan and section continues today, as can be seen in Herzog de Meuron’s new Tate extension, Switch House, opened in London in 2016.

The buildings featured in this issue reflect the evolution and eclectic range of architectural styles that have been produced across the globalized, industrialized world during the past few decades. Advances in computer aided design, robotics, materials, and green technology will continue to affect the design and construction process in future decades. New architectural languages will inevitably be developed by generations of architects who build on and reinterpret ideas and are able to construct ever more complex forms with state-of-the-art materials. These ideas will no doubt be quickly disseminated and absorbed by the global community of architects, receptive to new ideas and innovations.

Anna Roos

The Seater: From the Concrete Garden Collection

The Seater is among the latest furniture pieces offered by Swisspearl for garden and outdoor areas. The seat, created by the Slovenian architect and designer Tina Rugelj, persuades with its simple silhouette.

The Seater forms a part of the Concrete Garden outdoor furniture collection, designed by Slovene architect Tina Rugelj. The collection reveals another side of concrete aesthetics, transforming cold material into elegant shapes; and thin objects into strong structures. Made of natural fiber cement, it is strong enough to endure any weather condition.

The form of the Seater takes advantage of the unique qualities of fiber cement: the thinness, minimum roundness, and strength of the material. The Seater is produced with either a left or right armrest. The two variants can be combined to create a two-seater chair. Seater is made out of 16-mm-thin fiber cement and celebrates the look and feel of raw

concrete. Tiny imperfections are visible on the surface and the material gains a noble patina as it ages.

The Seater represents the spirit of the Concrete Garden collection. The Design Society of Slovenia honored the Concrete Garden collection as the Best Furniture design of the year 2013. It was published in several international media, such as the Financial Times, and CNN Style selected it as one of the top ten design products of 2015.

Design: Tina Rugelj
Year of design: 2013
Dimensions: 80 × 70 × 63 cm
Weight: 37 kg



Curtains on the Outside

Film is a medium of illusion par excellence. What would seem more obvious than to also stage the façade of a cinema complex as an optical illusion? The Mall of Switzerland complex shows the way this works with a curtain, of all things, which is certainly not a projection space.

Approaching the Mall of Switzerland, a shopping and leisure center in Lucerne's Ebikon district, from the northeast, one is seemingly taken in by an optical illusion: in back lighting, a floating, black box looms from the sky.

The cinema complex first shows its true face when one arrives at the address Ebisquare-Strasse 1. The box disperses into a meticulously arranged drapery, which swings around the building volume above the ground floor as an eleven-meter-high receding and projecting cloth.

In *Textile Art: In Itself and Considered in Relation to Architecture*, Gottfried Semper effectually, timelessly established that textile is an architectural material. And the feigning of textiles has been a theme in art history since the legendary competition be-

tween Zeuxis and Parrhasios, when the latter fooled his rival with a painted curtain. Parrhasios is meant to have painted it so realistically that Zeuxis wanted to push aside the veil in order to better view the painting behind.

The effect when one stands before the building of the multiplex cinema is similar. In any case, one almost waits for the curtain to open and the cinema spectacle to begin.

In fact, the creators of the building, Burkhardt + Partner, Zurich and TGS Architekten, Lucerne, turned the inside of the cinema outward, as it were—but not in that they transformed the façade into a film screen. Instead, they covered the building with the adaptation of the cur-

tain that covers the projection surface in traditional movie theaters.

In order to create as closely related an image as possible, as was the intention of the architects, the course of folds would have to be irregular, as is the case with the curtain panels in the theater. In addition, they were not satisfied with a mere visual association. In their realization, they also strove to match the original in terms of materialization, that is, for a textile quality.

The handmade, specialized work in Payerne did justice to both demands. Fiber cement is well suited in terms of materiality in its haptic qualities; and its manufacture also stirs associations with the handling of cloth, as the “widths of material” are formally “milled” in order to “imprint” them with the desired silhouette.

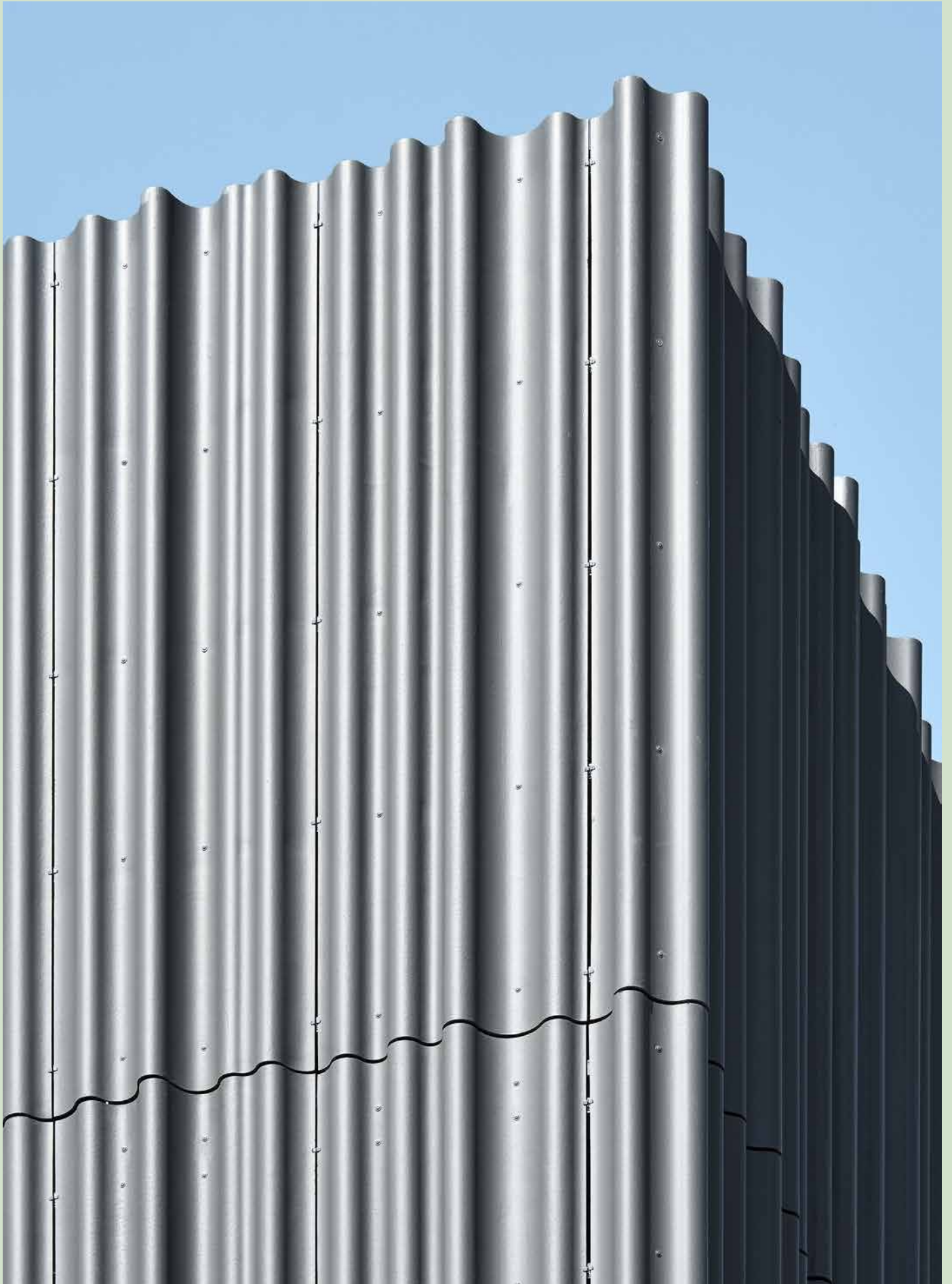

Pre-made formwork acts as a mold to establish the precise undulating curvature.



FORMAL AND STRUCTURAL

The development of peaks and valley was one of the challenges. Their radiuses should not be too narrow and the differences between heights and depths should not be too great. The former would have led to fissures in the fiber cement, the latter, with a material width of 125 centimeters, to one wave per length. The maximum height difference was thus set at 15 centimeters. In order to add additional dynamics to the pattern of folds, two different mold forms were designed. By turning each one 180 degrees, four different elements thus arose.

From a distance, the rhythm is nearly impossible to decipher. The eye is confused by the projecting and receding of the folds so that the intervals cannot be separated from one another. The pattern is first revealed from close proximity. The two forms as well as their orientation alternate in each case. That means that first the two forms follow one another—let's call them B and C—and then also their horizontally mirrored counterparts \bar{B} and \bar{C} . B, C, \bar{B} , \bar{C} results.

The method of attachment onto the sub-construction is also now apparent: Shadow gaps show that as compared to the use of “classic” Swisspearl panels, a stronger dilatation had to be taken into account. This was also the reason for the development of new, custom, screw connections.

It now becomes apparent that the entire truth is first revealed in the interplay of long-range and short-range effects: the two perspectives are, quasi, the flip-side of the same coin. The formal analogies with a curtain correspond with the structural solution as a “curtain wall.”

The cover of the cinema building is thus a genuine skin.

Rahel Hartmann Schweizer

CINEMA COMPLEX IN THE MALL OF SWITZERLAND

Location: Ebisquare-Strasse 1, Ebikon, Switzerland

Client/Investor: Silver Moss C Retail 2014 Sàrl, Luxemburg; Migros-Pensionskasse, Schlieren

Project Development: Halter AG, Entwicklungen, Zurich/EbiSquare AG, Ebikon

Architects: Burckhardt + Partner AG, Zurich/TGS Architekten AG, Lucerne

Building period: 2014 – 2017

Total Services Contractors: Halter AG, Gesamtleistungen, Zurich/Allreal Generalunternehmung AG, Zurich



The cut, but still wet fiber cement is rolled out.

The fiber cement, rolled out like lengths of material, is uncoiled and fit into the formwork.





The “material” is meticulously smoothed, so that it traces the formwork precisely.

The fiber cement elements piled up to dry.



The pattern first becomes legible up close: the two forms as well as their orientation alternate. The sequence is: B, C, \mathfrak{B} (horizontally mirrored), \mathfrak{C} (horizontally mirrored).

For the sake of uniformity, the necessary openings are covered with a perforated metal weave that has the same rhythm of folds as the Swisspearl elements.

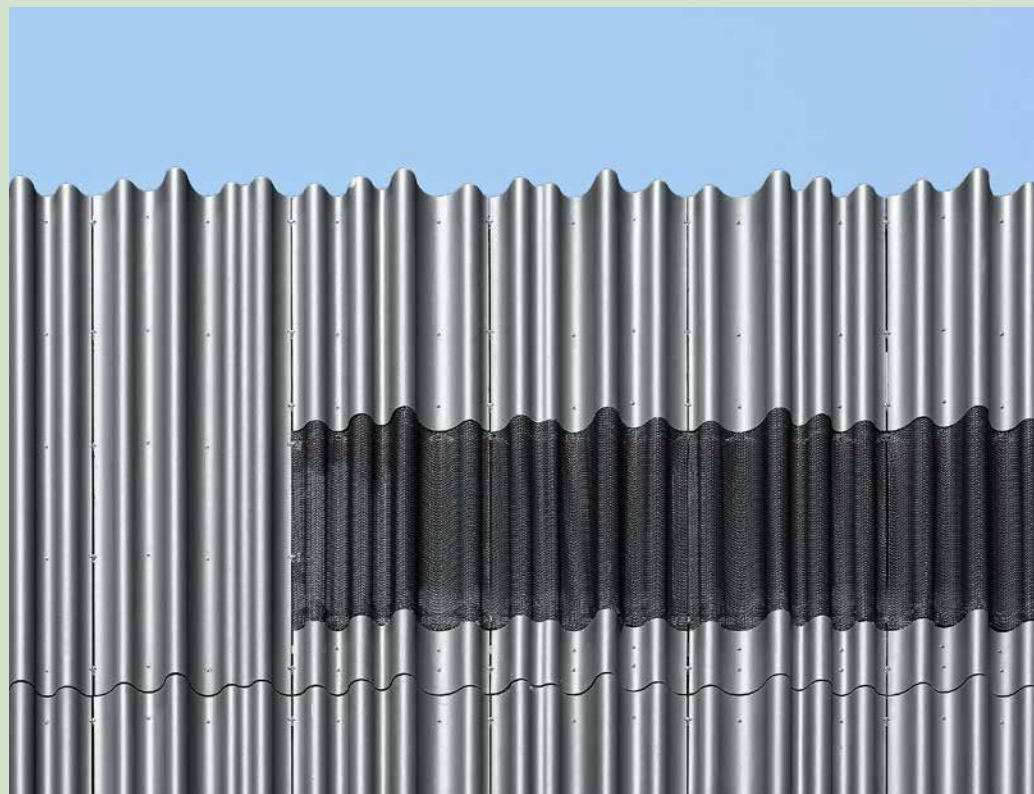

EMPLOYEE PORTRAIT



Dominik Baumgartner, Polymechanic

Dominik Baumgartner grew up tinkering with both his computer and his motorcycle. Now, at the age of 20, he has finished dual training as a polymechanic, completing both a classic apprenticeship and a vocational baccalaureate. As an all-rounder in precision mechanics, he has honed those childhood skills into a career, moving with ease between CAD drafting and machine toolmaking, and from planning and problem-solving to assembly and repair.

His favorite part of the process? “The end stage, when everything is working perfectly. I love seeing the results.” He also loves precision. “Our work is measured in hundredths of millimeters, that’s like a fraction of a human hair.” That kind of accuracy is necessary for the creation of Swisspearl’s distinctive façade elements. “Our job is to make sure the equipment is running perfectly at all times, so that production continues to be flawless.”

Dominik lives in Niederurnen, in a family home just minutes away from the Swisspearl facility. A big chunk of the money he earned as a vocational trainee has gone toward his favorite leisure activity: downhill mountain biking, the perfect outlet for his love of both accuracy and speed.

A bad bicycle crash in his early days didn’t daunt him: after six months of rehab for a head injury, he was right back out on the trails. The experience taught him a lot: “When I first started, it was all trial and error. Now I only take calculated risks. I take big jumps—but only when I know they’re going to work.”

He has already travelled in his Ford Transit van through half of Europe, attending competitive downhill events and looking for new trails and terrain. Next summer he will begin his military service. And after that? Further training, perhaps. Dominik is optimistic about “Industry 4.0” and the new challenges automation will provide for skilled workers. “What can I say?” he laughs. “Machines are my thing.”

Marcy Goldberg

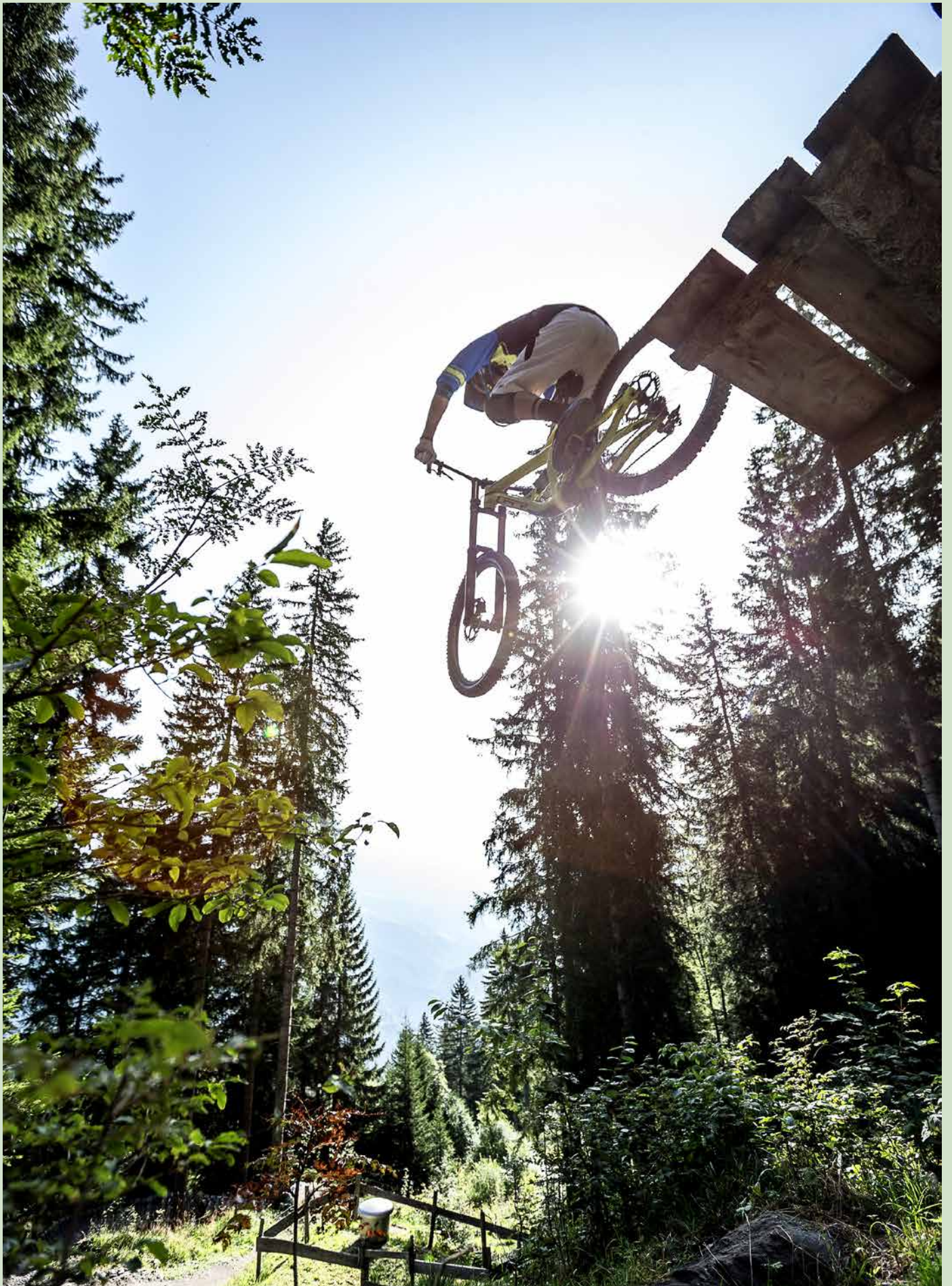





“Risk is unavoidable. But I always try to assess the situation and decide if it’s worth it. After all, I need to be able to go in to work on Monday morning.”



“We shot the photos in the Old Town in Chur, and above on the slopes in Brambrüesch, where I’ve trained a couple of times. The scenery is breathtaking, even if I have to concentrate on my bike.”



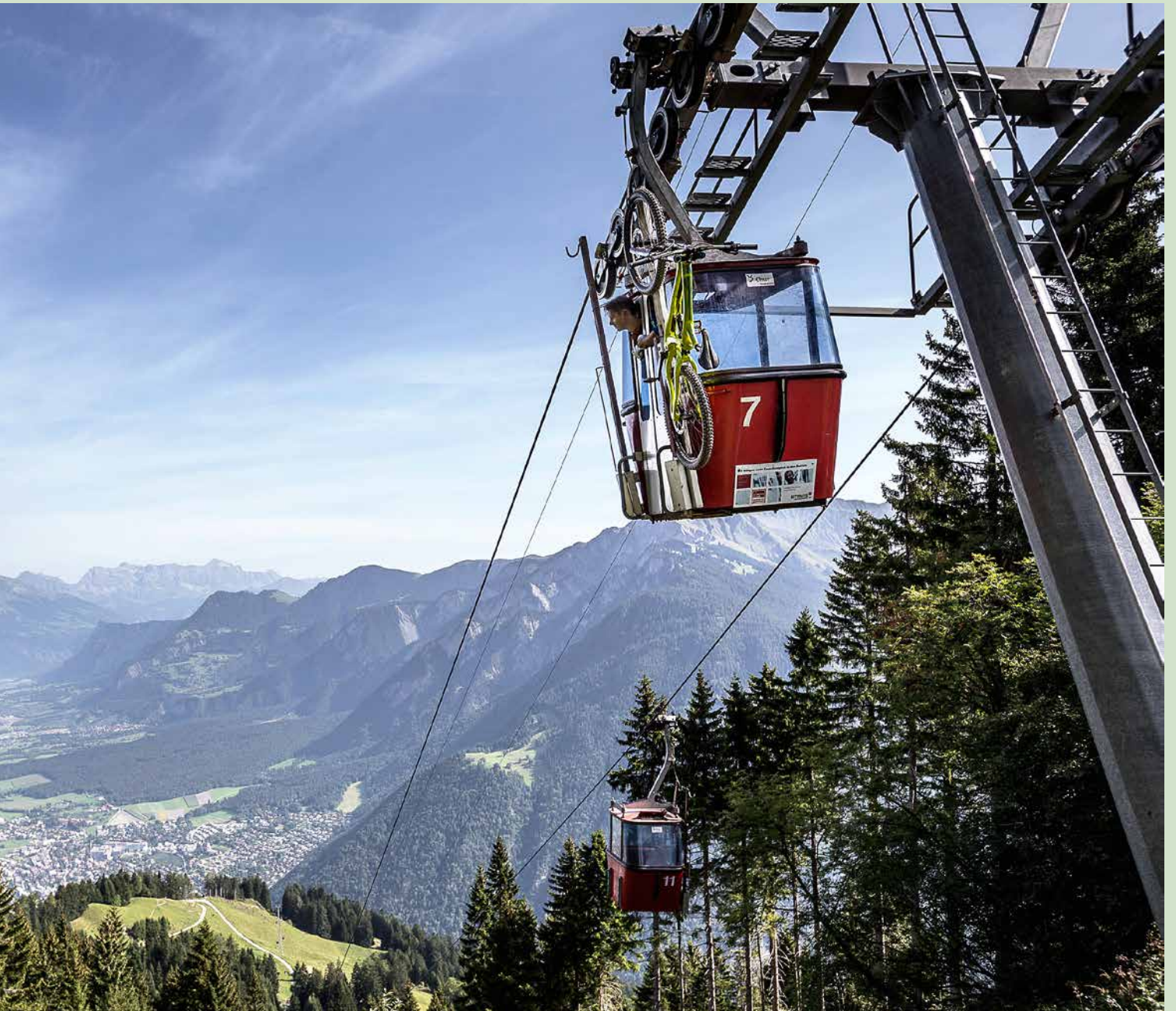

“My van is my mobile workshop, where I do all my own maintenance and repairs. Cycling is a pretty technical sport, and I love optimizing things. I can rebuild my bike from scratch if I need to.”



PROFILE

Name: Dominik Baumgartner

Age: 20

Job: Polymechanic

Character: Perfectionist, ambitious, full of life

Hobbies: Downhill mountain biking, traveling



Focus 1

Arhiv Grada, Novi Sad, Serbia

Pro-Ing

Transparent glass surfaces emphasize the contrast between the solid structures of the State archive building. One requirement in obtaining permission to build a public facility within a residential area is that it “communicate” with the urban surroundings. Volumetrically, the building is a freestanding structure with a complex form of interlocking volumes articulated by various façade surfaces. Solid surfaces are clad in Swisspearl fiber cement panels in various shades of warm and cool greys, counterbalanced by large glazed surfaces. The uniformity of the façade is emphasized when the double height folding shutters are closed. Delicate vertical perforations limit the amount of light that enters the depot space.

LOCATION: 2a Filipa Višnjića, Novi Sad, Serbia
CLIENT: Novi Sad Municipality
ARCHITECT: Pro-Ing Ltd., Novi Sad; Marija Milin Krunić, Milica Stojčević
BUILDING PERIOD: 2011–2013
GENERAL CONTRACTOR: Best izgradnja d.o.o., Novi Sad; Paraćin, Novi Sad
FAÇADE CONSTRUCTION: Ivkom plus/9.maja Smederevska Palanka
FAÇADE MATERIAL: Swisspearl Carat, Black Opal 7020, 7021, 7025 and Sapphire 7060



STUDENTSKI
RESTORAN



Asymmetrical, Yet Sleek

Student Restaurant, Varaždin, Croatia

A single, low-slung volume opens onto a green lawn: a meeting place for students to take a break, enjoy a meal, and exchange ideas.

The new student restaurant on the Varaždin University campus resulted from a collaborative effort by the investor, the City of Varaždin, the architectural team, and the building contractor to realize one of the city's first public buildings certified as nearly zero carbon emission. A primary goal is to act as a catalyzer for a "green energy" ethos spreading to all university campuses in Croatia.

The student restaurant is an elongated, asymmetrical single-story building, which is functionally divided into three zones: a public space with two restaurants (the main student restaurant and the à-la-carte restaurant); kitchen block and service facilities (toilets, staff rooms, etc.); and, finally, technical and installations spaces (located above the kitchen). The building is designed to comply with cutting edge international standards of green architecture and features solar panels and wind sensors; complete computerized management

of installations, lighting, surveillance and security; and video updates of energy consumption, etc.

To achieve a low carbon footprint, the architects utilized natural resources (water, sun, orientation, etc.) in their design. Moreover, the choice of materials played an important role in keeping with an environmentally friendly approach. White, sandblasted Swiss-pearl panels are the primary façade cladding material wrapping around the sleek form. With its environmentally friendly approach, the campus aims to expand its offer of services to the student body and beyond, fostering a stronger sense of environmental responsibility in the next generation of adults. The hope is that other campus building projects around the country will be inspired to upgrade or construct new buildings that match the high environmental standards achieved by this building.

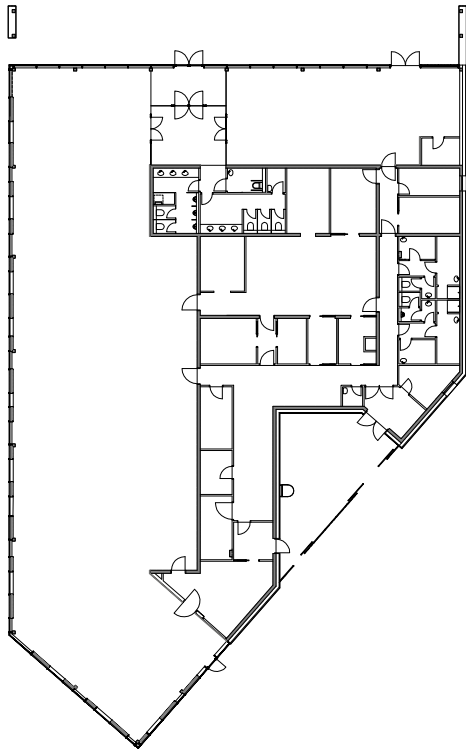

FIRST FLOOR 1:500

Timber fins act as acoustic absorbers and emphasize the elongated form of the student restaurant. A band of white fiber cement panels wraps around vertical floor-to-ceiling windows (above right).

The glazed façade on the northern elevation has been recessed to create an undercover outdoor eating area (below right).

LOCATION: Ul. Julija Merlića, Varaždin, Croatia

CLIENT: University of Zagreb

ARCHITECTS: Sangrad and AVP, Zagreb;
Vedran Pedišić, Mladen Hofmann, Erick Velasco
Farrera, Iva Marjančević, Hrvoje Davidovski

BUILDING PERIOD: 2014

GENERAL CONTRACTOR: Hidroing d.d., Varaždin

FAÇADE CONSTRUCTION: Limarija Gužvinec, Radovan

FAÇADE MATERIAL: Swisspearl Sandblasted,
White 8790







JW MARRIOTT

JW MARRIOTT

Most Frequented Building

Mall of America Phase Expansion and JW Marriott Hotel,
Bloomington, Minneapolis, USA

The large-scale Mall of America is a hub for
the residents of Bloomington, providing
tourist accommodation at the JW Marriott Hotel and
a myriad of shops and restaurants.

The Mall of America in Minneapolis opened its doors to the public in 1992 and is now the most frequented building in the United States with over 42 million visitors per year. In an effort to preserve this notable status, Triple Five Group decided to reinvigorate the existing mall through an expansion, which would reinforce the center's strong brand and status as a tourist destination.

Started in 2012, the extension added over one million square feet to the center, which included a retail expansion, luxury hotel, office tower, and underground parking. The new glazed entry gives the mall an outward orientation and draws visitors to the activity within. With its terrazzo flooring, stone wall details, and concealed indirect lighting, the retail expansion is centered around a grand atrium that utilizes active tinting glass. The exterior of the retail podium consists of a Swisspearl

rainscreen and continuous glazing, which provide a backdrop to a dramatic installation at the entry.

The JW Marriott is a new, fifteen-story luxury hotel with 342 rooms, full service restaurant, bar, lounge, pool, fitness center, meeting spaces, and executive lounge. The hotel structure comprises post-tensioned concrete in the guestroom tower and structural steel with composite decks in the hotel's public meeting space. The enclosure is designed as a rainscreen system made from Swisspearl, metal panels, and a glass curtainwall.

The office tower to the west of the hotel with a steel superstructure, is also clad in Swisspearl panels and has a glazed curtainwall. The tower is crowned with dramatic LED lighting on the exterior balconies where guests can enjoy panoramic views of the CBD and the Minnesota River Valley.







To counterbalance the dominant horizontal emphasis, the vertically proportioned short elevations are subdivided in vertical opaque fiber cement panels and reflective glass panels that mirrors the sky.

LOCATION: 60 East Broadway, Bloomington, Minnesota, USA
 CLIENTS: Triple Five and Hotel Development LLC, Minneapolis
 ARCHITECTS: DLR Group, Minneapolis; Ed Wilms
 CONSTRUCTION PERIOD: 2014–2015
 GENERAL CONTRACTOR: Mortenson, Minneapolis
 FAÇADE INSTALLER: MG McGrath, Maplewood
 FAÇADE MATERIAL: Swisspearl Carat, custom color

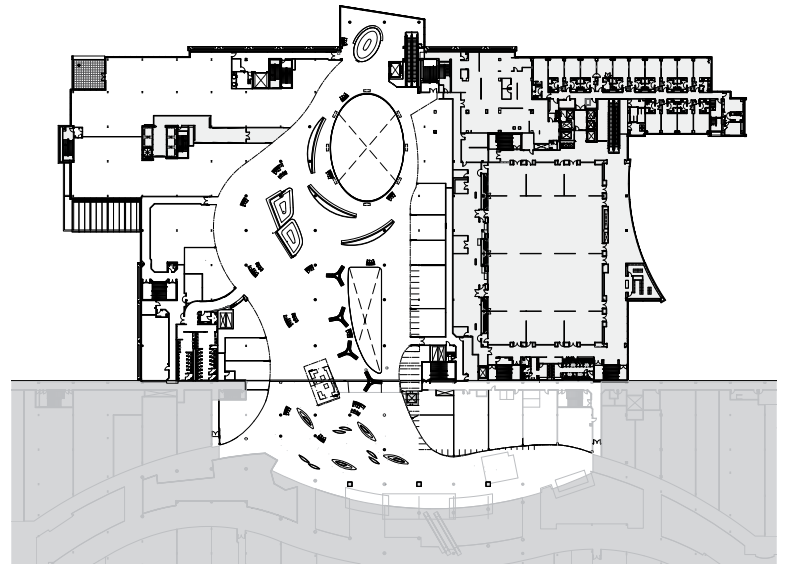

THIRD FLOOR

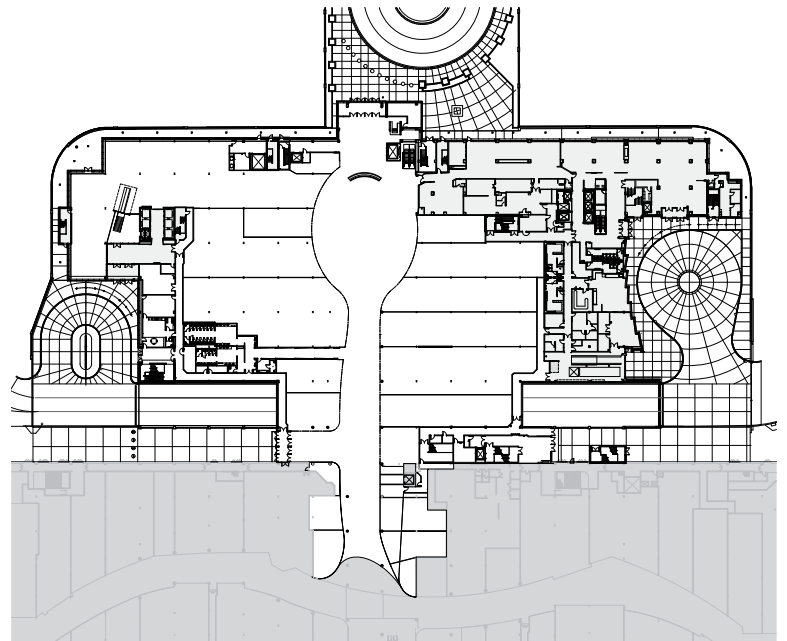

FIRST FLOOR 1:2000





POLK STANLEY WILCOX

Connecting Urban and Rural

Neptune Office Building,
Rogers, Arkansas, USA

Neptune Office Building is articulated in long, extended parallel lines of layered materials: stone, glazing, Swisspearl panels, and steel flashing in tightly packed, overlapping panels. Interlocking forms protrude from the façade envelope covered by the timber-clad eaves overhang that protects the upper floor outdoor balcony.

This 42,000-square-foot office building in Rogers, northwest Arkansas was designed by Polk Stanley Wilcox architects for Mars Incorporated. For a state primarily known for its countryside and agriculture, there is a surprising amount of commerce in this part of Arkansas. Wal Mart requires all businesses that would like to sell their products in their stores to have a “brick and mortar” office within proximity of their headquarters. Due to this requirement, hundreds of businesses have offices in the area, so that they can sell to the corporate giant. With this high density of commercial activity, competition is high. Businesses have to try and lure the most talented employees by providing world-class facilities that promote a healthy work environment.

As the commissioned architects, we were given the brief to create a building that served

the needs of the developer and the tenants, but that was also novel and unlike any other office building. The site is situated on the border of a low-density residential area and a thriving commercial district in Rogers. With this location, we were able to create a special place of urban connectivity in a rural environment. The building is nestled in a field of wild flowers and other indigenous plants and is bordered by a forest. Long ribbon windows enhance the natural lighting and sense of openness inside, while also providing pleasant views of the landscape beyond.

There are also a variety of covered exterior spaces that further enhance the relationship to the outdoors. A stone base anchors the building to the site and long narrow bands of Swisspearl panels express movement along the length of the building.

Complex façades of interlocking recessions and projections belie the simplicity of the floor plan. A floating canopy held by steel I-beams articulates the entry (above right).

A mélange of materials is drawn out in horizontal bands across the northern and southern façades (below right).

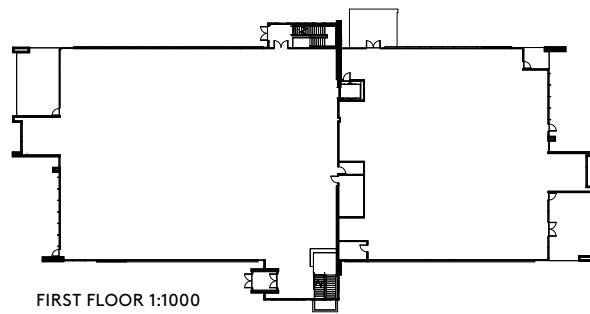

LOCATION: 3070 S.Champions Blvd., Rogers, Arkansas, USA
CLIENT: Mars Inc., McLean
ARCHITECT: Polk Stanley Wilcox, Fayetteville
BUILDING PERIOD: 2016–2017
GENERAL CONTRACTOR: C. R.Crawford, Fayetteville
FAÇADE CONSTRUCTION: Performance Contracting Inc. (PCI), Phoenix, in collaboration with Architectural Design
FAÇADE MATERIAL: Swisspearl Carat, Crystal 7010 and Black Opal 7025 (Sigma 8 and 12)





Focus 2

Maxima HQ, Vilnius, Lithuania

Gedimino Jureviciaus Studija

Maxima LT is Lithuania's largest retail chain. Its administration was previously spread out among different locations around the city. The new building houses the entire administration team under one roof. Maxima's request was to design an exclusive building that is also economical and does without luxury elements. The architect was asked why he chose Swisspearl panels for the façade: "The impeccable surface quality, range of colors, and mechanical resistance as well as the price and quality ratio determined our choice of Swisspearl."

LOCATION: 84 Naugarduko Street,
Vilnius, Lithuania

CLIENT: Maxima LT, Vilnius

ARCHITECTS: Gedimino Jureviciaus Studija,
Kaunas

BUILDING PERIOD: 2016–2017

GENERAL CONTRACTOR: Mitnija, Kaunas

FAÇADE CONSTRUCTION: Staticus, Vilnius

FAÇADE MATERIAL: Swisspearl Carat,
Black Opal 7025 F



Focus 3

High School, McKinney, Texas, USA

Stantec

The sensitive transformation of this 1980s building reestablished McKinney High, the community's first high school, as the foremost educational facility in the district. To draw students and the community into the newly renovated campus, Swisspearl composite panels were used to help identify the main entrance and house a new, advanced science laboratory block, providing a modern, engaging architectural element that is highly visible from the surrounding streetscape. The Swisspearl panels also highlight the entry into the cosmetology area, used for both student training and services for the community. Durable, refined finishes in neutral shades were selected to connect with existing finishes, while upgrading the campus and creating a modern learning environment.

LOCATION: 1400 Wilson Creek Parkway,
McKinney, Texas, USA

CLIENT: McKinney ISD

ARCHITECTS: Stantec (formerly SHW Group),
Plano

BUILDING PERIOD: 2010–2013

GENERAL CONTRACTOR: Pogue Construction,
Dallas

FAÇADE CONSTRUCTION: R. M. Rodgers Inc.,
Houston, and Underwood Sheetmetal Inc.,
Houston

FAÇADE MATERIAL: Swisspearl Carat,
Sapphire 7061 and Swisspearl Reflex,
Champagne 9290





Combining New Materials with Old

Villa Martinuzzi, Pula, Croatia

This villa is a good example of a successful combination of Swisspearl panels with stone. A dialogue occurs here between the two interlocking materials, contrasting textures, and corresponding color tones.

When undertaken carefully, combining traditional and modern elements in the renovation of historic buildings can result in wonderful living spaces. A prime example of this is Villa Martinuzzi by Tobis Engineering, located in Pula, a picturesque seaside town in Croatia known for its protected harbor, beach-lined coast, and Roman ruins.

The aim of the current owner of the villa, a young businessman from Zagreb, was to renovate it in a manner respectful to the existing 1890 house without being a slave to historical design codes. The challenge for project architect Nataša Jozipović was to find a balance between the charming historic house and a con-

temporary intervention. Forty-five-centimeter-thick stonewalls create a solid, rustic plinth for the lightweight first floor, which is clad in Swisspearl panels. The ground floor accommodates a modern kitchen, original staircase, bathroom, bedroom, living room, and dining room. A section of the pitched roof is glazed, allowing natural light to filter through the hallway on the upper level all the way down to the ground floor. The upper floor contains two bathrooms and three bedrooms. The interiors are minimalist with industrial details, as is often seen here, in the Istrian region. A color palette of white and light gray plays an important role in creating bright interiors.

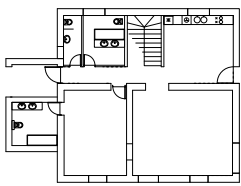
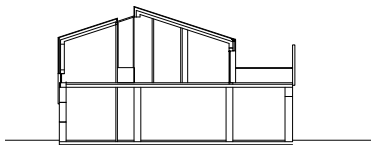

FIRST FLOOR 1:500

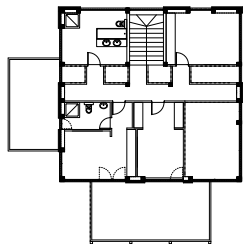

UPPER FLOOR



LOCATION: Pula, Croatia
 CLIENT: Ladonja turizam d.o.o., Zagreb
 ARCHITECTS: Tobis Engineering, Zadar and Zagreb;
 Nataša Jozipović
 BUILDING PERIOD: 2013/14
 GENERAL CONTRACTOR: Gecko d.o.o., Belgrade
 FAÇADE CONSTRUCTION: Imal plast d.o.o., Osijek
 FAÇADE MATERIAL: Swisspearl Reflex,
 Champagne 9290

Above left: At the corner junctions, fiber cement panels overlap the lower level stonework, while horizontal openings visually separate the two contrasting materials and create a band of clerestory windows.

Below left: The original exposed timber joints are a visual reminder of the former ceiling.

Right: The invisibly attached panels are mounted horizontally and vertically.

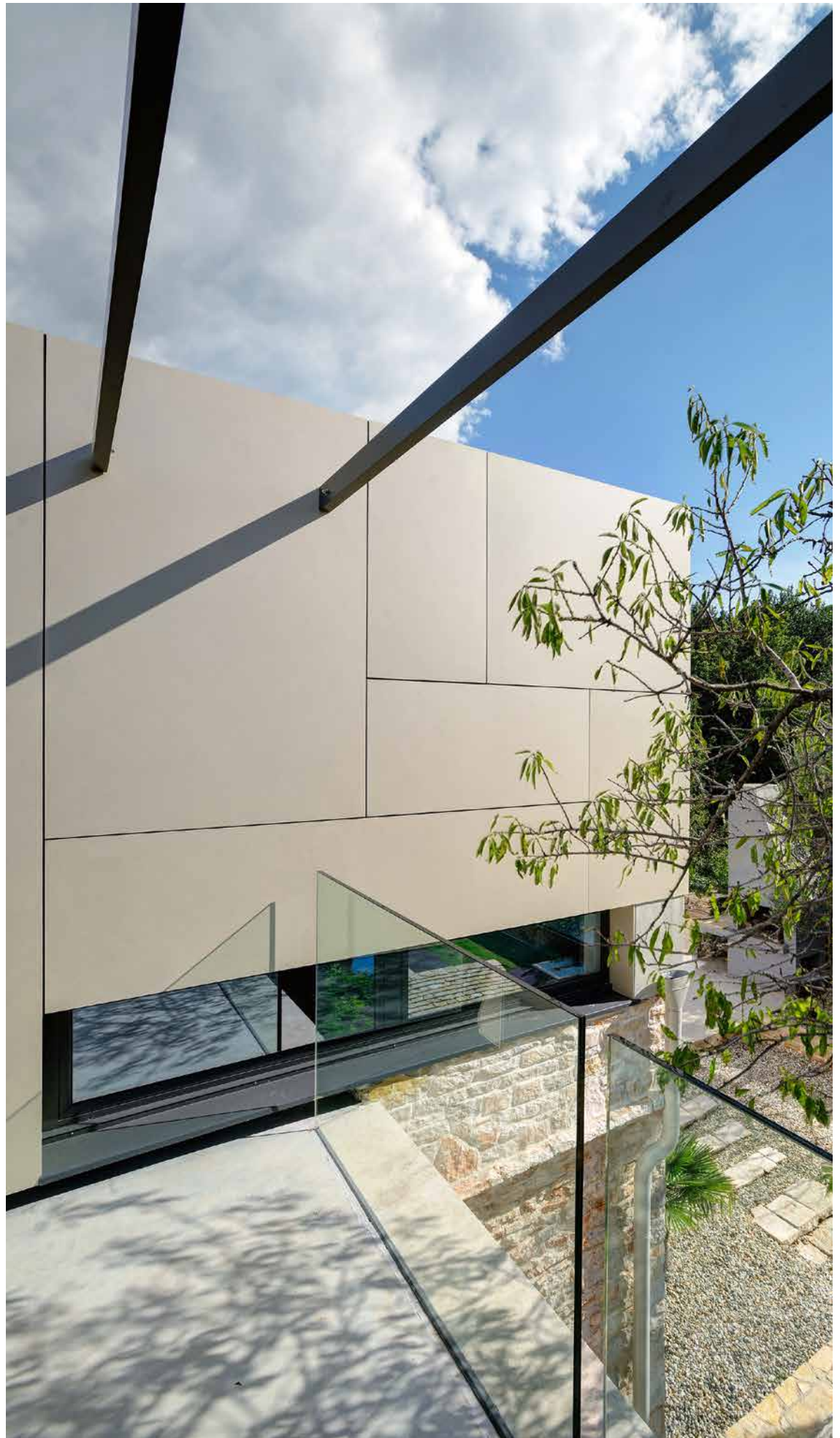



The floor of the upper level passageway is glazed to allow interesting views and light down to the lower level.

Bands of sunlight wash across the brushed concrete floor bringing natural light into the open plan kitchen area.

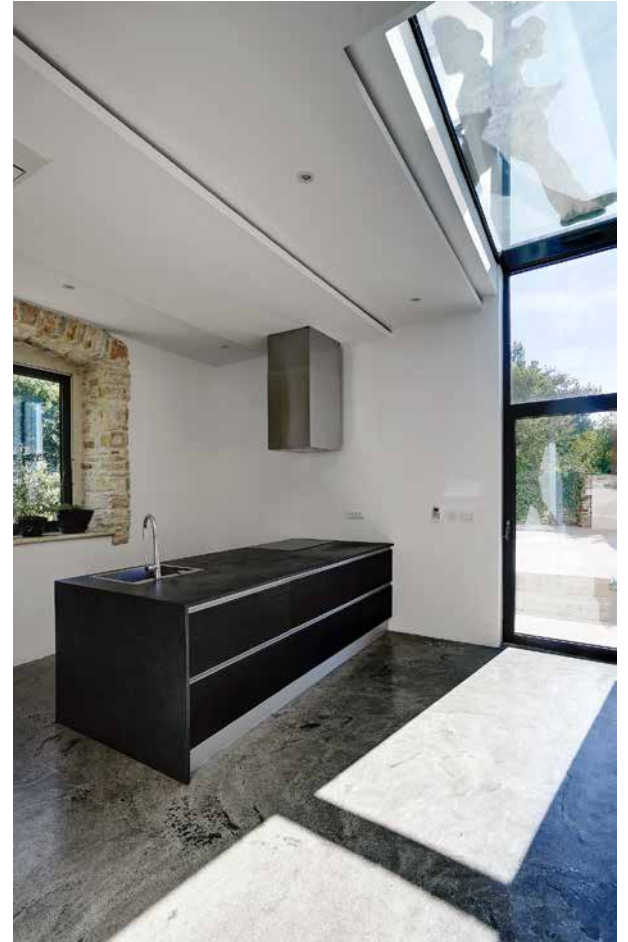





A Circular Volume Enclosed by Woven Strips

Ospedale del Mare, Naples, Italy

IaN+ has designed an expressive, single-story circular structure for the new reception building of the Ospedale del Mare (Hospital of the Sea) in Naples. The delicately layered façade in marine colors avoids the sterile, rather unwelcoming appearance so many of us are accustomed to in hospital buildings.

The new reception areas of the Ospedale del Mare in Naples by the architecture firm IaN+ were opened in March 2015. A new public square links the city to the hospital and the new reception area distributes access and service functions around a bright, sunlit entrance hall. The project was developed by IaN+ using the hospital guidelines drawn up by Renzo Piano in 2001. The layout plan specified a reception area that would accommodate the psychological well-being of patients, their relatives, and staff. The low-slung, curved building refers to a public piazza and integrates various reception services, as well as a system of circulation routes providing access to the hospital. Project architect Luca Galofaro says, “It’s an important

project for us and I think it will be for the city of Naples, too.”

IaN+ has clearly demarcated the new reception area with their unusual, curved design and woven exterior surfaces clad with colored panels of Swisspearl fiber-reinforced concrete and glass. The entire three-story volume is bathed in light that filters through the curtain of glass imbued with blue and green tones, echoing the ocean, which the building is situated alongside of. When the sunshine reflects off the cladding, the faceted façade shimmers like the scales of a fish and when the building lights up at night, it resembles the watery colors of an aquarium.





LOCATION: Via Enrico Russo, Naples, Italy
 CLIENT: ASL Napoli 1 Centro, Naples
 ARCHITECTS: laN+, Rome; Carmelo Baglivo, Luca Galofaro, Stefania Manna
 BUILDING PERIOD: 2013–2015
 GENERAL CONTRACTOR: P.F.P. Partenopea finanza di progetto S.c.p.a., Naples
 FAÇADE CONSTRUCTION: Giuliani Soc. Coop, Forli
 FAÇADE MATERIAL: Swisspearl Carat, Azurite 7041, 7042, 7043 and Jade 7050, 7051, 7052

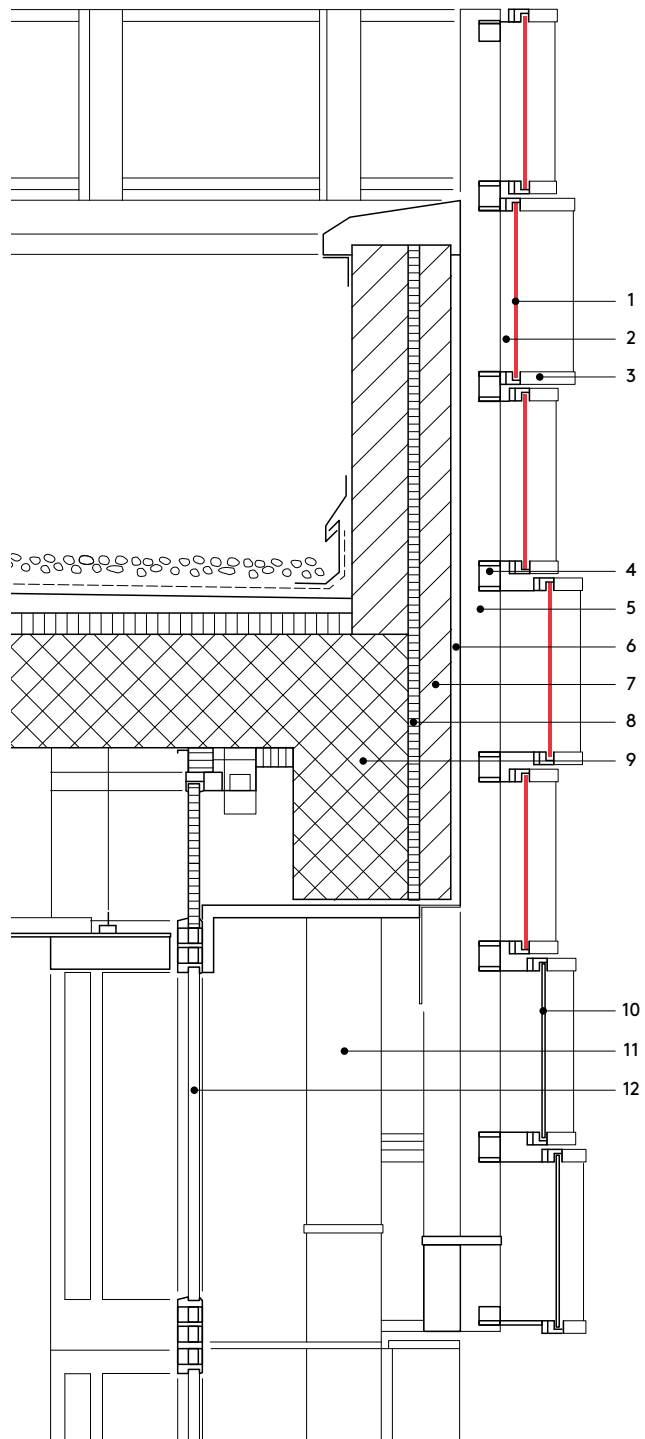
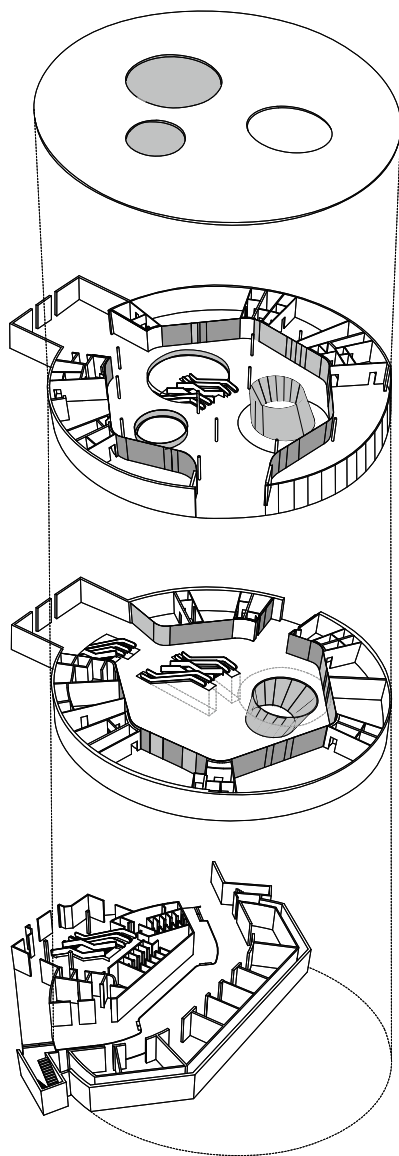

VERTICAL SECTION 1:20

- 1 Swisspearl, 8 mm
- 2 ventilation cavity
- 3 C-profile
- 4 sub framing
- 5 vertical sub framing
- 6 plaster
- 7 brickwork
- 8 thermal insulation, mineral wool
- 9 concrete
- 10 glass pane
- 11 column
- 12 glazing



laN+ wanted to create a landmark with their expressive design. The new structure clearly demarcates the entry, which was designed to be welcoming to hospital clients.

Left: Subtle shades of greens and blues intertwine in a mosaic of marine hues.







Seamus Heaney HomePlace

W M GIVEN

Poetic Color Range

Seamus Heaney Home Place, Bellaghy, Northern Ireland

The Heaney Center is a new community arts center in Bellaghy, County Londonderry. This small village is best known as the birthplace and childhood home of Irish poet and Nobel laureate Seamus Heaney, to whom the new building is dedicated.

The façades of the new community arts center, Seamus Heaney Home Place, are finished in various materials that blend harmoniously with Swisspearl cladding panels. Architects W M Given, based in Coleraine, Northern Ireland, have, in effect, reinterpreted the traditional rural barn in a myriad of textured materials, both traditional and contemporary: stone, wood, glass, and Swisspearl fiber cement panels. The mélange of materials creates a rich tapestry and a collage effect that results in a welcoming, human-scale building, appropriate to a community arts center. Long, single level stone walls perpendicular to the street, create a plinth for the second floor where the long façades are clad in vertical timber slats; and the gable ends in a random pattern of light grey, dark grey, and cream-colored Swisspearl panels. The protruding eaves are clad in slender timber slats, while a pop-out, glazed

balcony creates a deep covered overhang to the service entry on the ground level.

Apparently, W M Given favored Swisspearl cladding, not only because of the wide variety of colors available, but also due to its excellent environmental properties and longevity. The panels are environmentally friendly as neither the raw materials nor the production process contain any harmful substances. The fiber cement panels are manufactured from 95 percent natural raw materials from the Swiss alps: cement, pulverized limestone, water and air. This ensures an effective protection of material resources, avoiding unnecessary transport distances during the product's manufacture. Unfortunately, Seamus Heaney passed away in 2013, three years prior to the building's completion; one hopes he would have approved of the center dedicated to him.

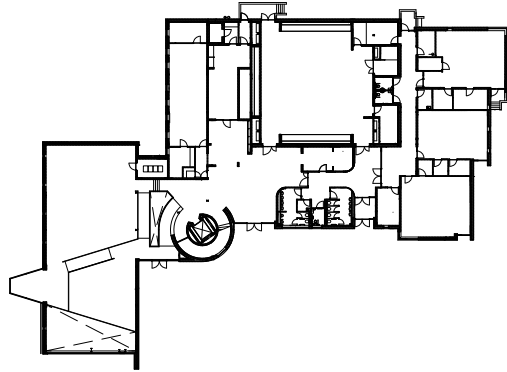
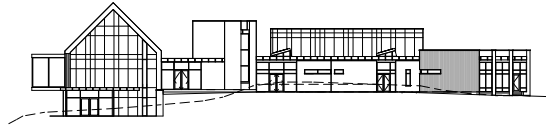

FIRST FLOOR 1:1000

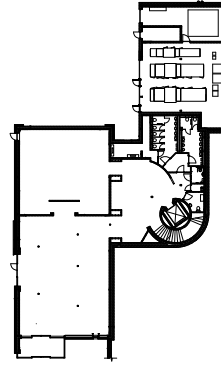

UPPER FLOOR

Light vertical timber slats counterbalance the dark stonewall on the lower floor.

The grey of the panels echo the brooding colors of the Irish skies (right).

LOCATION: 45 Main Street, Bellaghy, Northern Ireland
 CLIENT: Mid-Ulster District Council
 ARCHITECTS: W M Given, Coleraine
 BUILDING PERIOD: 2015–2016
 GENERAL CONTRACTOR: Brendan Loughran & Sons Ltd. Co., Omagh (Tyrone)
 FAÇADE CONSTRUCTION: Thornton Roofing, Toomebridge (Antrim)
 FAÇADE MATERIAL: Swisspearl Carat, Black Opal 7020 HR; Swisspearl Nobilis, Beige N813 HR and Grey N214 HR



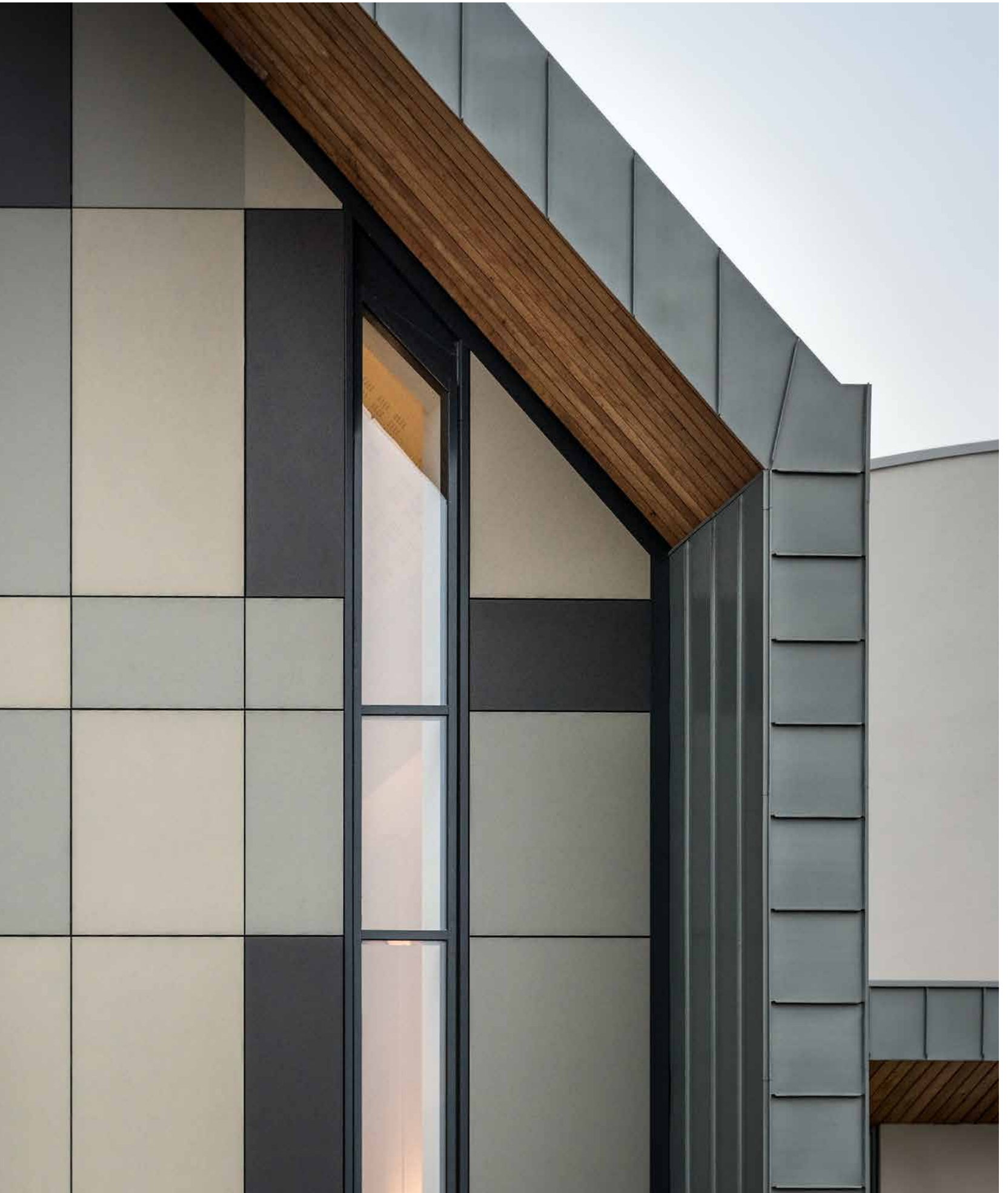

Focus 4

Office Building, Dunaújváros, Hungary

Finta Studio

This building complex is a crucial element in Dunaújváros's large-scale urban development project. An important aspect of the renovation is to open up and invigorate the previously rather somber environment. A generous, double-volume area was created on the ground floor to provide a lobby, temporary exhibition space, and a bar. The glazed wall of the main façade juts out, creating a new, external wall, through which visitors enter the building. This area leads to the new main staircase and elevator located in the lobby. All spaces around the building are public, as an important part of our concept to welcome the public. A durable, easily cleaned, sustainable, and graffiti-resistant material, namely light and dark grey Swisspearl fiber cement wall cladding, is a material we have used successfully in numerous other projects.

LOCATION: 1 Városháza tér, Dunaújváros,
Hungary

CLIENT: Dunaújváros City Council

ARCHITECT: Finta Studio, Budapest;
József Finta, Gábor Péter

BUILDING PERIOD: 2013–2014

GENERAL CONTRACTOR: Grabarics Swietelsky
Vemévszer consortium, Überlingen, Germany

FAÇADE CONSTRUCTION: Meilinger és Társa Kft.,
Keszthely

FAÇADE MATERIAL: Swisspearl Carat, Onyx 7099
and Swisspearl Nobilis, Grey N 215

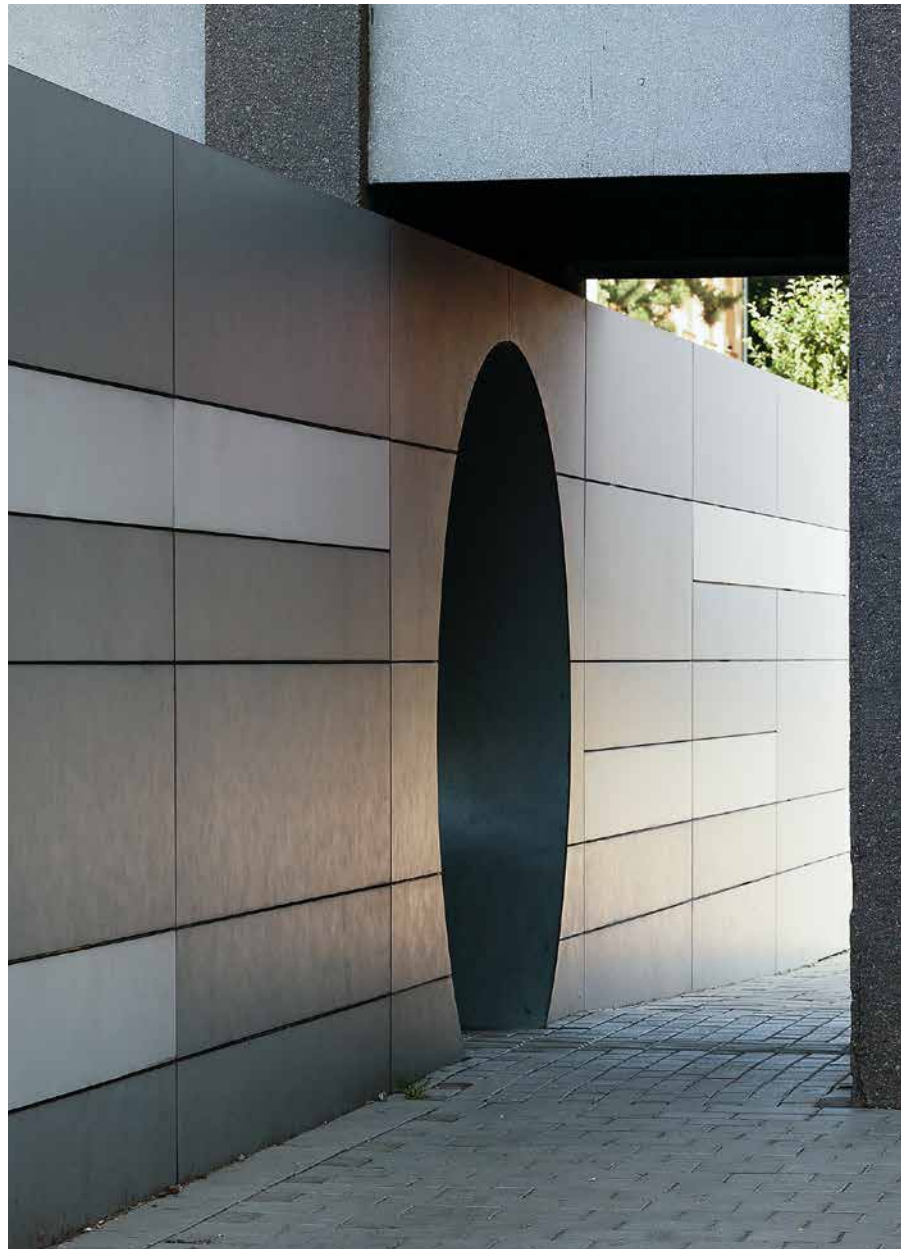

Focus 5

International School, Montréal, Canada

Birtz Bastien Beaudoin Laforest

École Enfants du Monde (International School) in Montréal was initially designed in 1961. Clad in Swisspearl panels, the new façades of the two-story, rectilinear school are mainly white, but are also peppered with black and red to give the school a sense of fun. The local borough experienced an annual increase in the number of primary school pupils, which prompted the School Board to expand several of its schools, most notably the Enfants du Monde school. Due to the design versatility of Swisspearl panels, Birtz Bastien Beaudoin Laforest Architectes decided to clad the École Enfants du Monde with the fiber cement material to add some color and a light-hearted atmosphere to the newly renovated building.

LOCATION: 2915, rue Marcel, Saint-Laurent, Montréal, Canada

CLIENT: The Marguerite-Bourgeois School Board, Montréal

ARCHITECTS: Birtz Bastien Beaudoin Laforest, Montréal

BUILDING PERIOD: 2013

GENERAL CONTRACTOR AND FAÇADE CONSTRUCTION: Construction Gamarco Inc., Laval

FAÇADE MATERIAL: Swisspearl Carat, Black Opal 7024, Coral 7031 and Onyx 7099





TOMÁŠ SOBOTA

Strips of Flying Windows

Air Transport Building, Bratislava, Slovakia

The new Air Transport Europe headquarters is a four-story building encircled by rings of wavy, undulating windows, which the architect refers to as “flying windows”—a metaphor for the dynamism of flight.

The client, Air Transport Europe, has provided air rescue systems, air transport, and helicopter maintenance service and support since 1991. The headquarters are built near the entry to Slovakia’s main airport in Poprad at the base of the Tatra Mountains. This new building by architect Tomáš Sobota accommodates additional administrative office space in Bratislava, Slovakia’s capital. Sobota’s aim was to design a simple orthogonal building, using a monochrome color-palette that was nevertheless neither unobtrusive nor boring. His primary architectural expression is his “flying windows” that weave their way around the façades, creating an impression of movement from both the exterior and interior. All windows are supplied with electric blinds, which enable the regu-

lation of solar radiation during hot summer days allowing employees to work in a glare-free environment. Solar panels are used for water heating.

The building is constructed with a concrete skeleton and clad with a suspended thermal and ventilation façade system of white Carat Swisspearl panels. The orthogonal panels are irregularly cut and shaped to create continuous bands framing the four horizontal bands of windows that encircle the building. Rather than being embedded into the site, the manner in which the architect has placed the building onto the level terrain with the half-height band of panels running along ground level creates the impression of the building as an object placed onto the site.

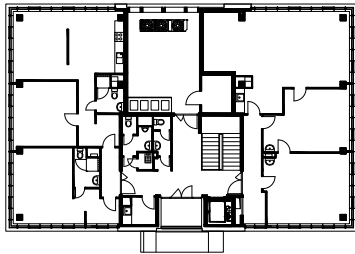
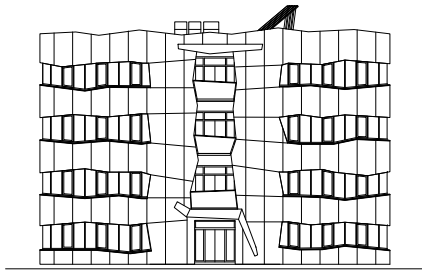
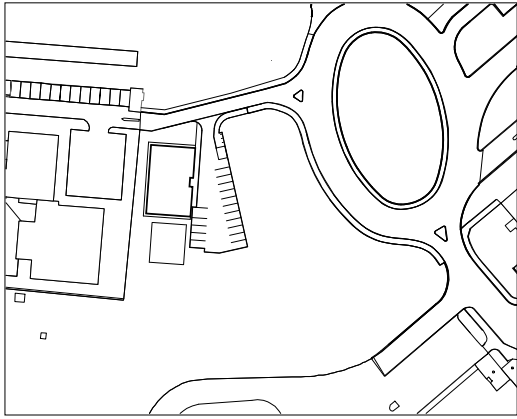

FOURTH FLOOR

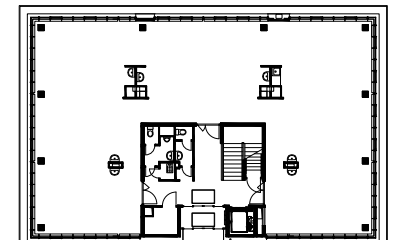

FIRST FLOOR 1:500





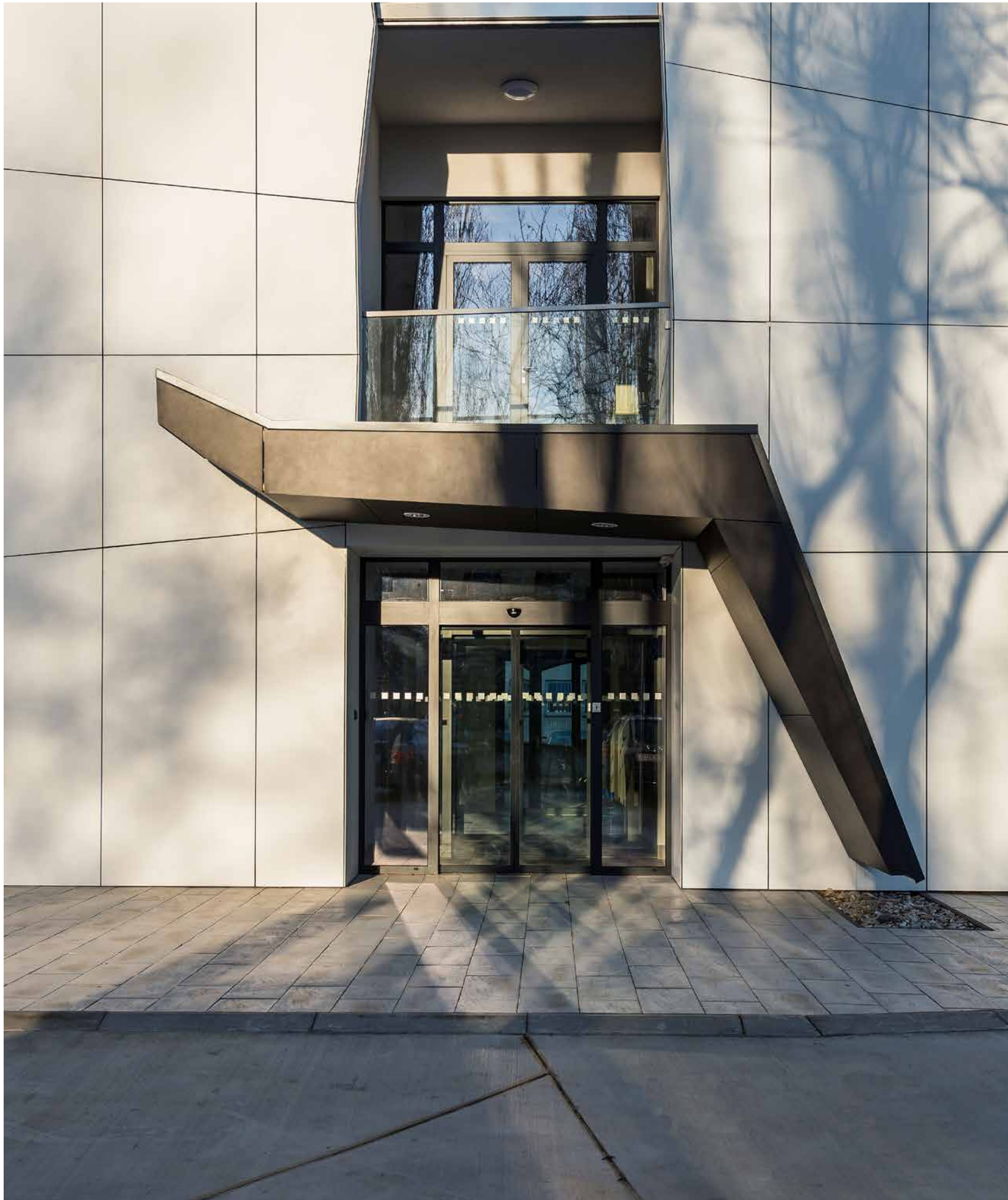



A wing-like projecting canopy articulates the entrance (left).

Undulating strip windows afford views of the surrounding landscape and skies.

LOCATION: Airport of Gen.M. R.Štefánik entrance area, Bratislava, Slovakia
CLIENT: Air Transport Europe s.r.o., Poprad
ARCHITECTS: Tomáš Sobota, Banská Bystrica
BUILDING PERIOD: 2013
GENERAL CONTRACTOR: Širila a.s., Spišská Nová Ves
FAÇADE CONSTRUCTION: Korp s.r.o., Nitra
FAÇADE MATERIAL: Swisspearl Carat, Onyx 7099 and Black Opal 7025



Shifting Panels Appear to Vibrate Across the Façades

B66 Business Center, Kaunas, Lithuania

The junction of this L-shaped business center is emphasized by a vertical volume clad in overlapping, vertical Swisspearl panels in jet black with clipped eaves and small punctured windows.

The total area of the three- to four-story business center in Kaunas, Lithuania, is approximately 5,300 square meters, the bulk of which is available for rental. Modern heating, cooling, and ventilation systems installed in the business center ensure a high level of comfort for employees and visitors of the center, which accommodates 400 workstations. Furthermore, a relaxation zone with benches and green spaces is provided in the inner courtyard. During the warmer summer months, this space can be used to eat or simply relax. A spacious parking area is provided near the newly renovated of-

face building. Swisspearl façade cladding in various tones has been utilized in both the exterior and the interior of the building. The delicate overlapping of the vertical junctions with vertical strips of black Swisspearl panels creates a playful sense of movement across the façades of the dark volume. This innovative surface treatment and the shifting play of window openings softens the façades and gives the central volume an interesting character, making it the focal point of the L-shaped ensemble. Clipped eaves and flat roofs enhance abstract interlocking volumes.

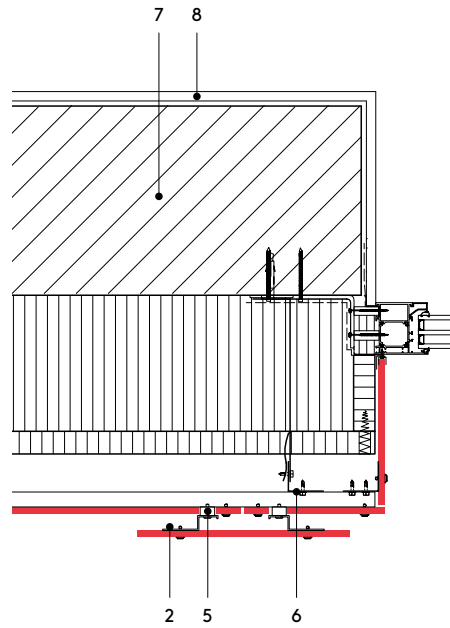
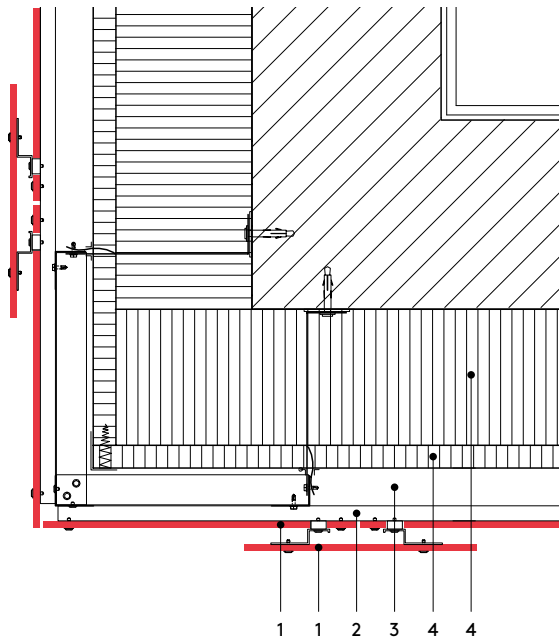

HORIZONTAL SECTION 1:10

- 1 Swisspearl, 8 mm
- 2 panel support profile
- 3 ventilation cavity
- 4 thermal insulation, mineral wool
- 5 stainless steel washer
- 6 L-profile
- 7 brickwork
- 8 gypsum plaster board

LOCATION: K. Baršausko 66, Kaunas, Lithuania
 CLIENT: UAB YIT Kausta Būstas, Vilnius
 ARCHITECT: Vytautas Janušaitis, Kaunas;
 Gražina Janulytė-Bernotienė, Danguolė Akuockienė,
 Surminas Petrauskas
 CONSTRUCTION PERIOD: 2016–2017
 CONTRACTOR AND FAÇADE CONSTRUCTION: AB YIT
 Kausta, Kaunas
 FAÇADE MATERIAL: Swisspearl Reflex,
 custom color 7024

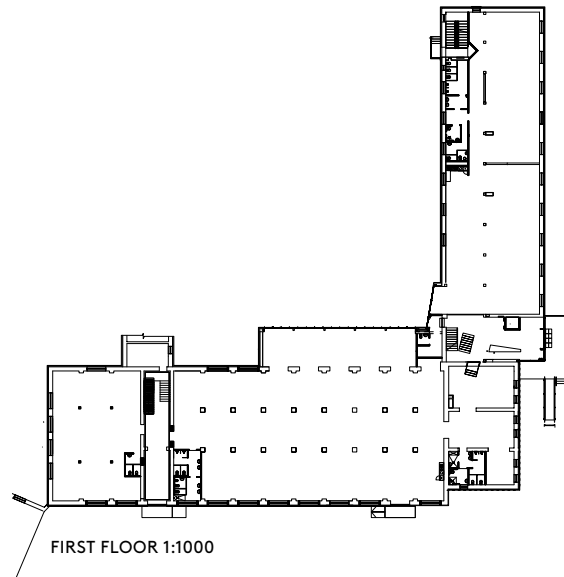

Overlapping panels create an animated dynamic across the façades.





IRENE GOLDBERG AND PITSOU KEDEM

Contemporary Living in a Coastal Town

N2 House, Herzliya Pituach, Israel

This stylish, single-family house in Herzeliya, north of Tel Aviv on the Mediterranean coast, has been designed as a succession of interconnected thresholds that proceed through the building. Aluminum latticework screens have been used as a device to create subtle intermediary spaces.

A series of progressive stages play out between the main entry gate and the rear garden of the N2 House. The first stage is crowned by a delicate aluminum lattice floating above the entrance, casting skewered geometric patterns across the walls. To the left as one enters the property, is a massive, concrete wall rising above a dark reflection pool, concealing the interior of the house from direct view. The second stage is situated beyond this massive wall, where a more private entrance hall reveals the house behind a glazed wall, which is used as a device for creating a transparent layer of separation. The third stage is where the main front door opens onto two hallways—the main entry leads through the heart of the house, while the second door simply leads to the guest bathroom. The fourth stage in the progression is along the main hallway, to the left of which is an internal patio rising three stories high. Located here are both a staircase and a sitting area. Progressing along the hall, the fifth stage

is revealed, where the semi-private kitchen and family room can be glimpsed through long, horizontal openings in the hallway wall. The final stages are revealed at the end of the hallway, where the living room is situated. Ultimately, this communal area opens onto an outdoor patio above which floats a lattice echoing the latticework at the entrance.

The hallway receives natural lighting from two window openings. One is a long and narrow opening positioned at eye level between the two private volumes that are separated by the communal areas. The other opening is a skylight above the hallway, which illuminates the space below with indirect light reflected off the inclined balustrade of the second story bridge. Here again, a delicate lattice pattern is used to filter light from the skylight opening above. N2 House offers a high quality of family life in a series of bright, sunlit interconnected spaces.



The open plan communal area extends directly out onto an outdoor terrace and the garden.

Delicate latticework casts complex geometric shadows (right).

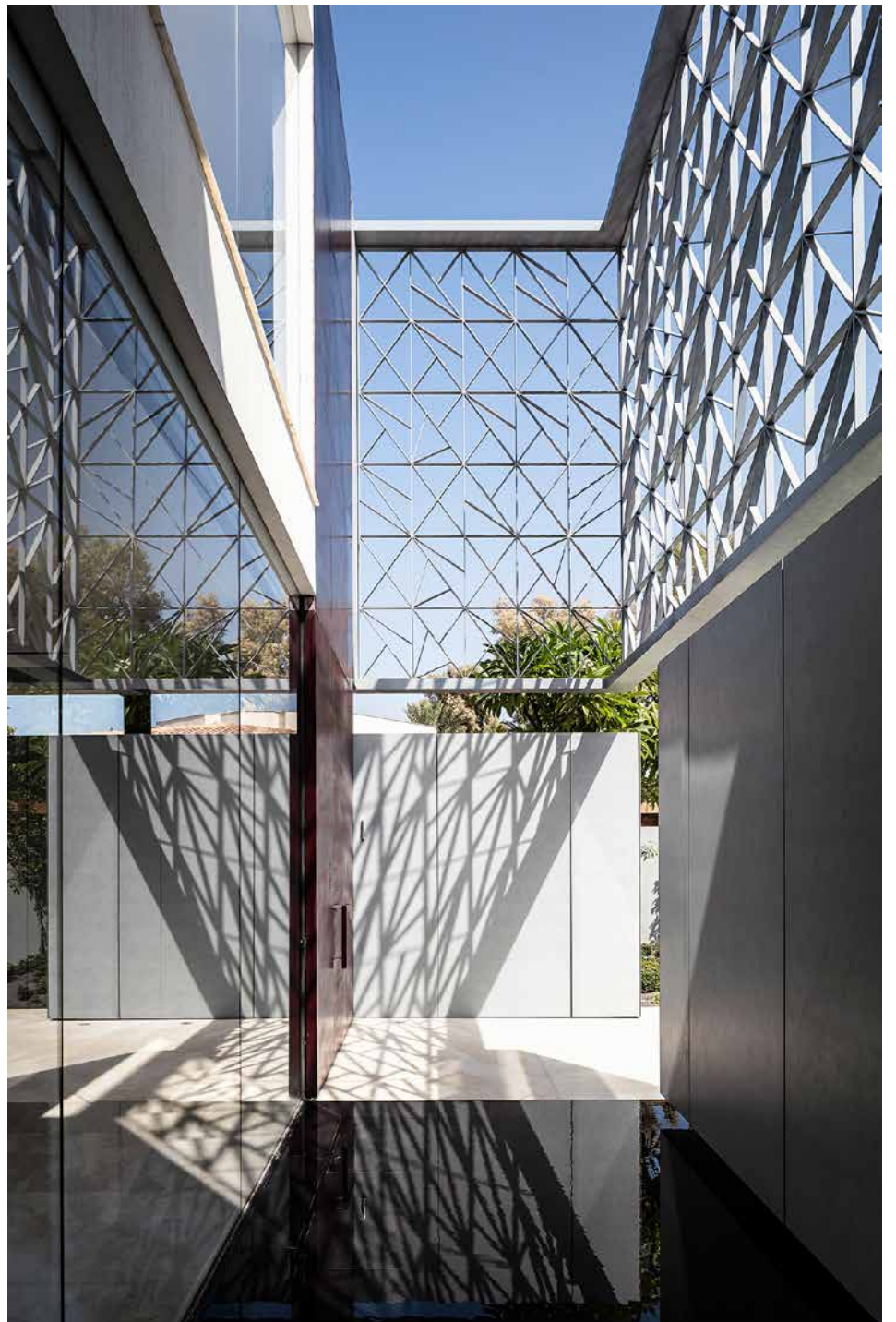

The upper level cantilevers over an outdoor lounge, allowing for sheltered outdoor seating.

A series of spaces is drawn out through the building, here the passageway is held by a double volume of fiber cement panels and a heavy concrete wall (right).

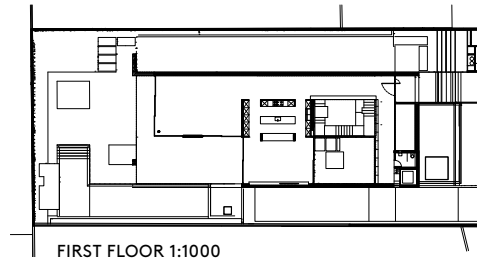

LOCATION: Herzliya Pituach, Israel
CLIENT: Private
ARCHITECTS: Irene Goldberg and Pitsou Kedem, Tel Aviv; with Raz Melamed
BUILDING PERIOD: 2013–2016
GENERAL CONTRACTOR: Yaron Tibet Construction Co.Ltd, 8, Lochamei Hageatot St., Ramat Hasharon Israel
FAÇADE CONSTRUCTION: Eyal Coatings Ltd.
FAÇADE MATERIAL: Swisspearl Nobilis, Grey N 215

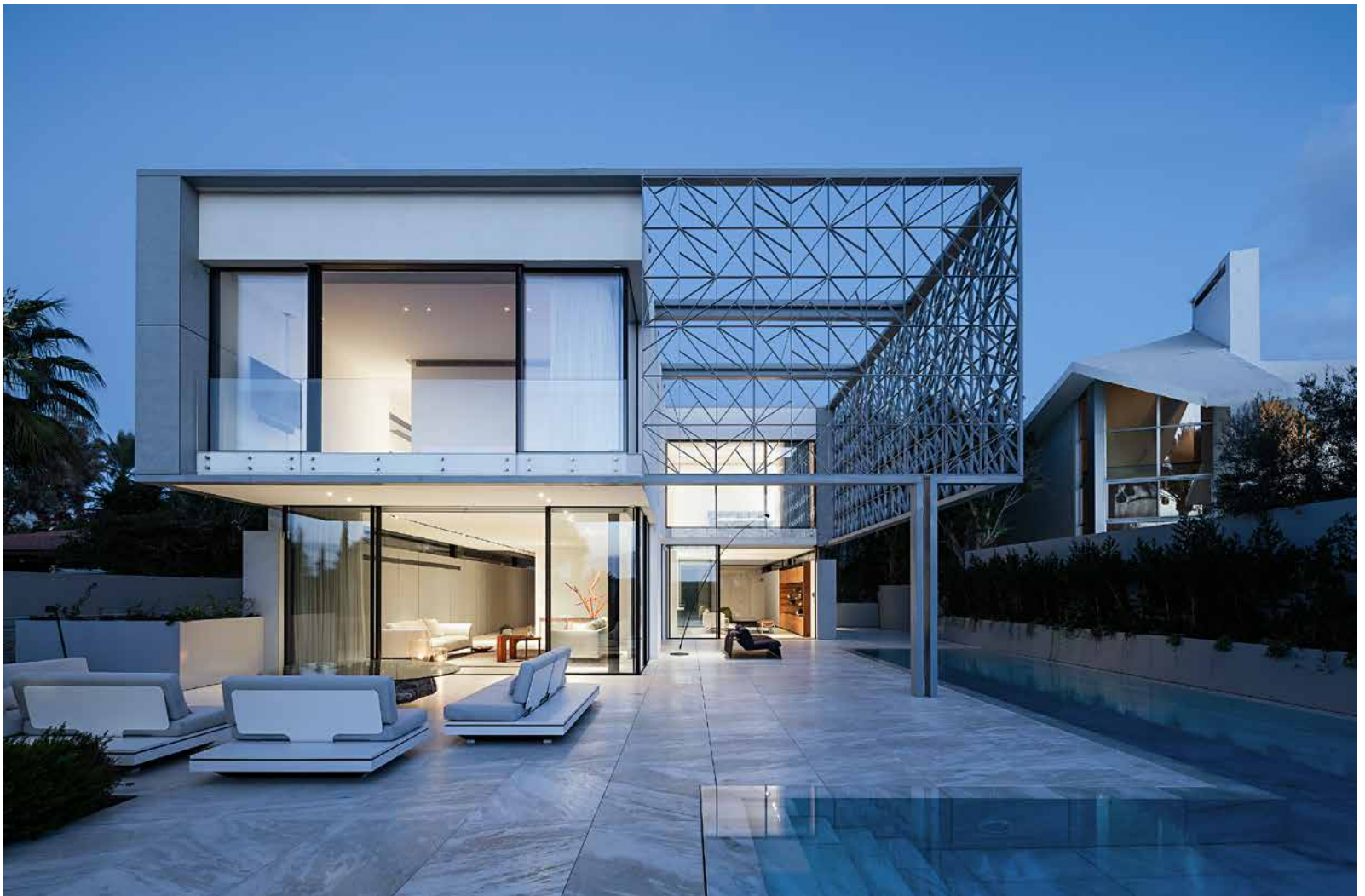

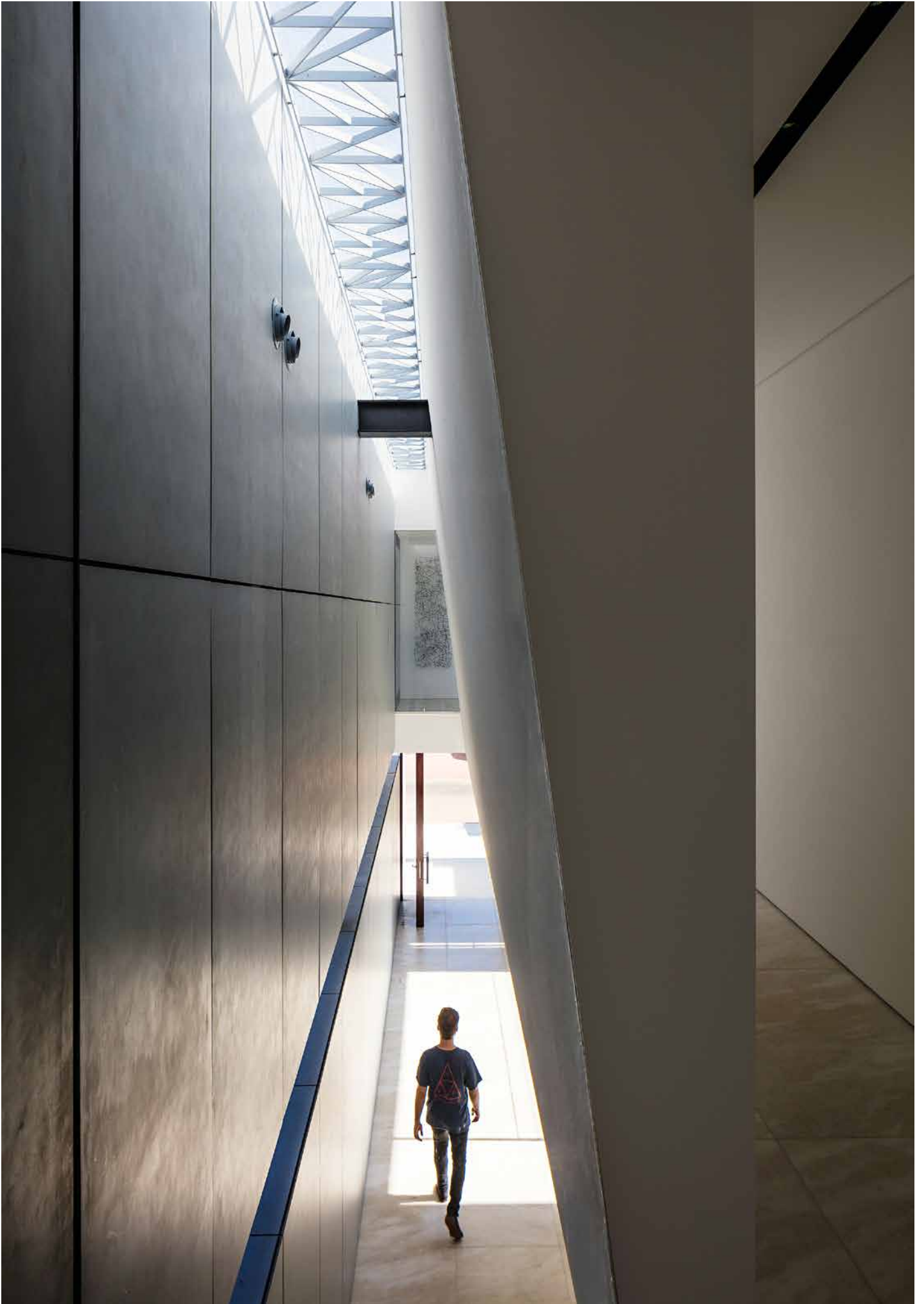

Focus 6

SAP Lobby, Budapest, Hungary

Vikár & Lukács

The concept was to create a flexible office for various types of business. Since it is the main entrance for the entire Hungarian SAP operations, the lobby is an important part of the overall concept. With the design of the entry space, Vikár & Lukács Architects create a strong statement. The aim was to use interior design elements that respect the space, yet gently form it. In accordance with SAP brand guidelines, the background of the logo was specified as white. These considerations prompted the choice of Swisspearl panels. Special surface textures were decided upon in order to add some detail to the white cladding. The Swisspearl panels are perforated with circular openings to increase the sense of energy.

LOCATION: Graphisoft Park, Budapest, Záhony utca 7, Budapest, Hungary

ARCHITECTS: Vikár & Lukács, Budapest

INTERIOR ARCHITECTS: MádiLáncos Studio, Budapest

BUILDING PERIOD: 2016–2017

GENERAL CONTRACTOR: Fitout Zrt., Budapest

FAÇADE CONSTRUCTION: Meilinger Kft., Győr

FAÇADE MATERIAL: Swisspearl Carat, Onyx 7090, Sapphire 7060, Jade 7050



Focus 7

Works Yard, Basel, Switzerland

Weberbuess

The works yard for the municipal cleaning and gardening departments of Basel is situated on a triangular site between sports fields, a youth center, and a park. Incorporating existing perimeter walls and an old, existing building, the new facility comprises four timber structures clad in white Swisspearl corrugated panels. To guarantee sufficient smoke extraction, the building insurer stipulated a 5 percent opening ratio for the fiber cement cladding. By using a perforated façade, the architects have managed to maintain the integrity of the overall wall surface. The precise placement of each perforation was key to creating a continuously changing façade image. Moreover, by varying the width and length of the perforations, the design team managed to create a pattern and provide a sense of depth to the wall surface. By modifying the same pattern throughout the complex, a versatile, yet coherent image for the facility as a whole has been achieved.

LOCATION: Brennerstrasse 11, Basel, Switzerland
CLIENT: Immobilien Basel-Stadt (on behalf of the City of Basel)
ARCHITECTS: Weberbuess Architekten, Basel
BUILDING PERIOD: 2013
FAÇADE CONSTRUCTION: Stamm Bau AG, Arlesheim
FAÇADE MATERIAL: Swisspearl Ondapress-36, Natura N 6326



Impressum

The internationally distributed magazine *Swisspearl Architecture* sets Swisspearl fiber cement products within a contemporary architectural context.

Publisher

Swisspearl
CH-8867 Niederurnen
Switzerland
phone +41 (0)55 617 11 60
info@swisspearl.com
www.swisspearl.com

Advisory board

Michèle Rüegg Hormes,
sparc studio GmbH and consultant
Martin Tschanz, architectural theorist
and lecturer ZHAW

Editorial committee

Michael Hanak
Hans-Jörg Kasper
Jürg Schönenberger
Yasmin Willi
Robert Wirichs

Editor

Michael Hanak, Zurich

Editing

Marion Elmer, Zurich

Translation

Lisa Rosenblatt, Vienna

Design

Schön & Berger, Zurich

Detail plans

Deck 4, Zurich

Printing company

Buchdruckerei Lustenau, Lustenau

English edition

ISSN 1661-3260

Photos

Cover page, p. 2-13, 16 Gayle Babcock /
Architectural Imageworks, Springfield
p. 15 above Timothy Hursley, Little Rock
p. 15 middle Christopher Barrett, Chicago
p. 15 below Tim Griffith, San Francisco
p. 19 above Philippe Ruault, Nantes
p. 19 below Tonatiuh Ambrosetti, Penthalaz
p. 20 Nick Hufton and Al Crow, Hertford
p. 24-25 Klemen Razinger, Radovljica
p. 25-29 Jürg Zimmermann, Zurich
p. 31-36 Andrea Badrutt, Chur
p. 37 Milan Đakov, Belgrad, and
Vojin Ivkov, Novi Sad
p. 38-41 Sandro Lendler, Zagreb
p. 42-47 Richard Brine, Minneapolis /
Chicago/London
p. 48-51 Aaron Kimberlin, Chicago
p. 52 Martynas Slapsys, Vilnius
p. 53 above Luis Ayala, Houston
p. 53 below Elena Grey, Austin
p. 54-59 Vjekoslav Skledar, Zagreb
p. 60-63, 66-71, 80-83 Hannes Meraner
and Florian Hauser, Bolzano/Bozen
p. 65 Mario Ferrara, Caserta
p. 72 Török Tamás, Budapest
p. 73 Martin Gagnon/Forme Studio, Québec
p. 74-79 Peter W. Haas, Banská Bystrica
p. 84-89 Amit Geron, Tel Aviv
p. 90 Bujnovszky Tamás, Budapest
p. 91 Walter Mair, Basle
Back page Hannes Meraner and Florian
Hauser, Bolzano/Bozen; Amit Geron,
Tel Aviv; Martynas Slapsys, Vilnius; Gayle
Babcock / Architectural Imageworks,
Springfield; Peter W. Haas, Banská Bystrica

Legal notes

Texts, images, photos and graphic work in this publication are protected by copyright and other intellectual property rights. Rights to the texts are owned by the writers in all cases. The contents of this publication may not be copied, distributed, altered or made available to third parties for commercial purposes. Further, some pages include images the copyrights of which are owned by third parties.

This publication has been assembled with the greatest possible care. Nevertheless, the publisher cannot guarantee freedom from error and the complete accuracy of the information it contains. The plans have been kindly provided by the architects. The detailed plans have been reworked for greater legibility; the editors are not able to guarantee their accuracy.

Contacts

Headquarters

Chief Sales Officer
Robert Wirichs
+41 79 644 60 63
robert.wirichs@swisspearl.com

Office Manager Export
Sandra Winteler
+41 55 617 13 34
sandra.winteler@swisspearl.com

Marketing Manager Export
Yasmin Willi
+41 55 617 12 52
yasmin.willi@swisspearl.com

Order Processing
Giuseppe Azzato
+41 55 617 13 54
giuseppe.azzato@swisspearl.com

Head of Transport Disposition
Marlies Gebbs
+41 55 617 13 85
marlies.gebs@swisspearl.com

Area and Regional Managers

Africa & La Réunion

Laurent Boellinger
+336 7400 12 94
laurent.boellinger@swisspearl.com

Asia Pacific

Robert Wirichs
+41 79 644 60 63
robert.wirichs@swisspearl.com

China, Hong Kong & Taiwan

Chen Wei
+86 186 0175 5719
wei.chen@swisspearl.com

CIS Countries & Russia

Susanna Agne
+43 664 60011313
susanna.agne@swisspearl.com

Denmark & The Netherlands

Robert Wirichs
+41 79 644 60 63
robert.wirichs@swisspearl.com

Eastern Europe

Marjan Ernstsneider
+386 41 689 662
marjan.ernstsneider@swisspearl.com

France, Luxembourg, Belgium

Laurent Boellinger
+336 7400 12 94
laurent.boellinger@swisspearl.com

Italy

Enea Spini
+41 79 420 22 93
enea.spini@swisspearl.ch

Norway

Sigurd Sandvik
+47 99 60 90 25
sigurd.sandvik@swisspearl.com

South Eastern Europe

Ivan Simčić
+386 5 39 21 570
ivan.simcic@eternit.si

Sweden

Mikael Stridh
+46 40 41 00 73
mikael.stridh@swisspearl.com

Turkey, India, Near & Middle East

Mustafa Abbasoğlu
+90 533 242 93 82
mustafa.abbasoglu@swisspearl.com

USA & Canada

Harry Harisberger
+1 636 698 5505
harry.harisberger@swisspearl.com

Western Europe & Latin America

Victor Valero
+34 636 610 861
victor.valero@swisspearl.com

Technical Advisors

Asia, Middle East, France, Russia

Hansruedi Leuzinger
+41 79 159 79 10
hansruedi.leuzinger@swisspearl.com

Europe, Latin America, Pacific

Victor Valero
+34 636 610 861
victor.valero@swisspearl.com

Scandinavia

Lasse Jakobsen
+45 28 40 98 35
lasse.jakobsen@swisspearl.com

USA & Canada

Nick Sturm
+1 760 271 7940
nick.sturm@swisspearl.com

Colors

Carat

	Sahara 7000
	Sahara 7001
	Sahara 7002
	Crystal 7010 → s.p. 50
	Black Opal 7020 → s.p. 37, 70
	Black Opal 7021 → s.p. 37
	Black Opal 7024 → s.p. 73
	Black Opal 7025 → s.p. 37, 50, 52, 79
	Coral 7030
	Coral 7031 → s.p. 73
	Coral 7032
	Coral 7033
	Azurite 7040
	Azurite 7041 → s.p. 64
	Jade 7050 → s.p. 64, 90
	Jade 7052 → s.p. 64
	Sapphire 7060 → s.p. 37, 90
	Sapphire 7061 → s.p. 53
	Topaz 7070a
	Topaz 7071
	Topaz 7073
	Amber 7080
	Amber 7082
	Onyx 7090 → s.p. 10, 90
	Onyx 7091
	Onyx 7099 → s.p. 72, 73, 79
	Agate 7219

Avera

	AV 000
	AV 010
	AV 020
	AV 030
	AV 040
	AV 050
	AV 060
	AV 070
	AV 100

Reflex

	Silver 9000
	Platinum 9020
	Black Velvet 9221
	Dark Silver 9222
	Sunset 9230
	Crimson 9231
	Cobalt Blue 9241

	Autumn Leaves 9270
	Mystic Brown 9271
	Gold 9272
	Champagne 9290 → s.p. 53, 56
	Satin White 9291

Nobilis

	Black N 012
	White N 112
	Grey N 211
	Grey N 212
	Grey N 213
	Grey N 214 → s.p. 70
	Grey N 215 → s.p. 72, 88
	Red N 312
	Blue N 411
	Blue N 412
	Green N 511
	Green N 513
	Green N 515
	Yellow N 612
	Beige N 811
	Beige N 813 → s.p. 70
	Brown N 915

Zenor

	11006
	11115
	15015
	23048
	23057
	35005
	35126
	45047
	47030
	51074
	63077
	65061
	67007
	67014
	69046

Incora

	IN 100
	IN 090

**SWISS
pearl®**

